



CC-Link/LT Master Block Model FX2N-64CL-M

Please read this manual thoroughly before starting to use the product and handle the product properly.

User's Manual (Hardware Volume)



MODEL	FX2N-64CL-M
MANUAL Number	JY997D05401B
Date	JANUARY 2003

●SAFETY PRECAUTIONS●

This manual describes the name of each part, outside dimensions and specifications of the CC-Link/LT master block for Mitsubishi Programmable Controller (PLC).

For the design and construction of the CC-Link/LT system, refer to the CC-Link/LT Master Block Users Manual.

These ●SAFETY PRECAUTIONS● are classified into two categories: "DANGER" and "CAUTION".

DANGER Procedures which may lead to dangerous conditions or cause death or serious injury if not carried out properly.

CAUTION Procedures which may lead to dangerous conditions or cause minor to medium injury, or physical damage, if not carried out properly.

Depending on certain circumstances, procedures indicated by

CAUTION may also be linked to serious ramifications. It is important to follow the directions for usage.

[DESIGN PRECAUTIONS]

DANGER

- Construct an interlock circuit in the sequence program so that the system works correctly using the communication information when an error in the data link occurs. If such an interlock circuit is not provided, accidents may be caused by erroneous output or malfunction.

- When a remote I/O unit fails, inputs/outputs may randomly become ON or OFF; therefore build an external monitoring circuit that will monitor any input signals that could cause a serious accident. Accident may be caused by erroneous output or malfunction.

CAUTION

- Use the master block without applying any force on the master block and the flat cable dedicated to the CC-Link/LT. Otherwise, such cables may break or fail.

[INSTALLATION PRECAUTIONS]

DANGER

- Shut down all phases of the power supply outside the master block, then attach or remove the master block. If the power is not disconnected at all phases an electric shock or serious damage to the product may occur.

CAUTION

- Use the master block in the environment described in this manual. If the master block is used in an improper environment, then electrical shock, fire, malfunction, product damage or product deterioration may occur.
- Securely fix the master block with DIN rail or mounting screws. When using mounting screws, securely tighten them within the specified torque range. If the screws are too loose, the module may detach from its installed position, short circuit, or malfunction. If the screws are too tight, the screws may be damaged, which may cause the module to detach from its installed position or short circuit.

CAUTION

- Pay attention that foreign objects such as cuttings or wiring chips do not enter the master block. It may cause fire, product failure or malfunction.
- During installation and wiring works, adhere dust-proof sheets supplied together with the master block on the sides of the master block so that foreign objects such as cutting chips and wiring chips do not enter the inside. Otherwise, foreign objects may cause fire, failure or malfunction.
- Before operating the system, remove the dust-proof sheets so that heat can be released. It may cause fire, product failure or malfunction.

[WIRING PRECAUTIONS]

DANGER

- Shut down all power supplies, before starting the wiring work. If the power is not disconnected from all sources an electric shock or serious product damage may occur.

CAUTION

- CC-Link/LT network wiring uses the flat cable dedicated to the CC-Link/LT specified by CC-Link Partner Association (CLPA), and perform wiring in accordance with the specifications described in this manual. If any cable other than the dedicated flat cable is used or if wiring is performed in a method not conforming to the specifications, normal data transmission cannot be assured.
- Do not bind the flat cable dedicated to CC-Link/LT together with major circuits or power cables. Keep the dedicated flat cable away from major circuits and power cables by 100 mm (3.93") or more. It may cause malfunction due to noise interference.
- Accommodate the flat cable dedicated to CC-Link/LT inside a duct, or fix it with clamps. If the dedicated flat cable is loose or is pulled for movement or carelessness, the master block and the dedicated flat cable may be damaged or malfunction due to imperfect connection.
- Correctly wire the master block while confirming the rated voltage and terminal arrangement of the master block. It may cause fire or product failure.
- Hold the connector area when disconnecting the flat cable dedicated to CC-Link/LT from the master block. If the cable area is pulled, the master block or the dedicated cable may be damaged or malfunction.

[STARTING AND MAINTENANCE PRECAUTIONS]

DANGER

- Do not touch the terminals when the power is ON. It may cause an electric shock or malfunction.
- Make sure to shut down all phases of the power supply outside the master block before starting cleaning. If all phases of the power supply are not shut down, the master block may be seriously damaged or malfunction.

CAUTION

- Do not disassemble or modify the master block. Doing so may cause failure, malfunction, injury, or fire.
- The case of the master block is made of resin. Do not drop or apply strong impacts to the master block.

[DISPOSAL PRECAUTIONS]

DANGER

- When disposing of this product, treat it as industrial waste.

●Notification of CE marking●

This notification does not guarantee that an entire mechanical module produced in accordance with the contents of the notification comply with the following standards. Compliance to EMC standards of the entire mechanical module should be checked by the user / manufacturer.

Standards with which this product complies
Type : Programmable Controller (Open Type Equipment)
Models : Products manufactured from February 1st, 2003.

Electromagnetic Compatibility Standards (EMC)	Remark
EN61000-6-4:2001 Electromagnetic compatibility - Generic standards - Emission standard for Industrial environment	Following item is examined: - Radiated Emissions
EN61131-2:1994 Programmable controllers /A11: 1996 -Equipment requirements and tests /A12: 2000	Following items are examined: - RF Immunity - Fast transients - ESD - Damped oscillatory wave

For more details please contact the local Mitsubishi Electric sales site.
- Notes For compliance to EMC regulation.
It is necessary to install the FX2N-64CL-M in a shielded metal control panel.

Associated Manuals

Manual name	Manual No.	Description
CC-Link/LT Master Block Model FX2N-64CL-M User's Manual (Detailed Volume) (Japanese only)	JY997D06201	This manual contains the specifications, wiring, handling, etc. of the CC-Link/LT master block.

1. Product Outline

The CC-Link/LT master block FX2N-64CL-M can be connected to the FX Series PLC.

By using this master block, the CC-Link/LT system can be constructed while setting the FX Series PLC as the master station.

2. Part Name and Setting

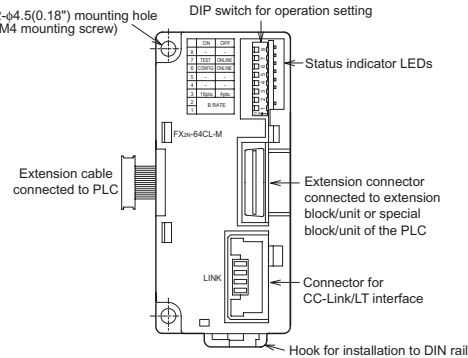

Name	Description
POWER	<ONLINE mode/CONFIG mode/TEST mode> Lit: Power is supplied Extinguished: Power is not supplied
	<ONLINE mode> Lit: Master block is operating normally Extinguished: Master block is abnormal Power is interrupted EEPROM read error (sum mismatch) occurred
RUN	<CONFIG mode> Lit: Master block is operating normally Extinguished: Master block is abnormal Power is interrupted
	<TEST mode> Lit: Master block is operating normally Extinguished: Master block is abnormal Power is interrupted
	<ONLINE mode> Lit: Communication speed setting error occurred EEPROM read error (sum mismatch) occurred Flickering: Power supplied for communication is abnormal DIP switch for operation setting was changed during operation Extinguished: Master block is operating normally
ERR.	<CONFIG mode> Lit: Communication speed setting error occurred EEPROM write error occurred Flickering: Power supplied for communication is abnormal DIP switch for operation setting was changed during operation Extinguished: Master block is operating normally
	<TEST mode> Lit: Communication speed setting error occurred Flickering: Power supplied for communication is abnormal DIP switch for operation setting was changed during operation Extinguished: Master block is operating normally
	<ONLINE mode> Lit: Communication speed setting error occurred EEPROM read error (sum mismatch) occurred Flickering: Power supplied for communication is abnormal DIP switch for operation setting was changed during operation Extinguished: Master block is operating normally

Name	Description															
L RUN	<ONLINE mode/CONFIG mode> Lit: Data link is being executed Extinguished: Data link is stopped <TEST mode> Lit: Self-loop back Test was finished normally Extinguished: Self-loop back Test was finished abnormally (Extinguished while the self-loop back Test is being executed)															
	<ONLINE mode> Lit: Use station number discrepancy (when BFM#32(20h) to #95(5Fh) is edited, the station numbers are checked.) Outside-control-range station error occurred Flickering: Stations are abnormal Extinguished: Data link is being executed normally <CONFIG mode> Lit: Use station number discrepancy (when BFM#32(20h) to #95(5Fh) is edited, the station numbers are checked.) Flickering: All stations are abnormal Extinguished: Data link is being executed normally <TEST mode> Lit: Self-loop back Test was finished abnormally Extinguished: Self-loop back Test was finished normally (Extinguished while the self-loop back Test is being executed)															
SD	<ONLINE mode/CONFIG mode/TEST mode> Lit: Data is being sent															
RD.	<ONLINE mode/CONFIG mode/TEST mode> Lit: Data is being received															
Interface Connector to connect the flat cable dedicated to the CC-Link/LT (24G/DB/DA/+24 V)																
DIP switch for operation setting	1 B RATE Communication speed setting <table border="1"> <thead> <tr> <th>Communication speed</th> <th>SW1</th> <th>SW2</th> </tr> </thead> <tbody> <tr> <td>156 kbps</td> <td>OFF</td> <td>OFF</td> </tr> <tr> <td>625 kbps</td> <td>ON</td> <td>OFF</td> </tr> <tr> <td>2.5 Mbps</td> <td>OFF</td> <td>ON</td> </tr> <tr> <td>Setting disabled</td> <td>ON</td> <td>ON</td> </tr> </tbody> </table>	Communication speed	SW1	SW2	156 kbps	OFF	OFF	625 kbps	ON	OFF	2.5 Mbps	OFF	ON	Setting disabled	ON	ON
	Communication speed	SW1	SW2													
	156 kbps	OFF	OFF													
	625 kbps	ON	OFF													
	2.5 Mbps	OFF	ON													
	Setting disabled	ON	ON													
	2 Point mode setting (Select the number of I/O points per station.) OFF : 4-point mode (4 input points and 4 output points in each station) ON : 16-point mode (16 input points and 16 output points in each station)															
	3 16pts/4pts															
4 -- Setting is disabled. (Make sure that it is OFF during operation.)																
5 -- Setting is disabled. (Make sure that it is OFF during operation.)																
6 CONFIG/ONLINE OFF : ONLINE mode (normal operation) ON : CONFIG mode (The information on connected stations is saved in the EEPROM.)																
7 TEST/ONLINE TEST mode OFF : ONLINE mode (normal operation) ON : TEST mode (Self-loop back Test)																
8 -- Setting is disabled. (Make sure that it is OFF during operation.)																

- Factory default, all bits of the DIP switch are set OFF.
 - The Test mode is selected when both the CONFIG and TEST mode are set ON simultaneously.
 - For each setting, the status at the time of power ON is valid. (If a setting is changed after the power is ON, such a change is invalid.)
- CONFIGMODE**
- BFM #32 (20h) to #95 (5Fh) changed value while online will cause a L ERR.
 - No remote module attached during power ON will result in no L ERR.
 - Remote module removed during operation will result in no L ERR.

3. Handling Cautions

The master block can be attached by way of DIN rail or attached directly with screws.

The installation procedure in each case is described below. Use the master block without applying any force on the cable.

3.1 Installation direction

- Do not install the master block on the floor surface, ceiling surface or in the horizontal direction. If the master block is installed in such a way, its temperature may rise. Install the master block vertically on the wall surface as shown in the figure below.
- Secure a space of 50 mm (1.96") or more between the master block and other equipment or structure. Keep the master block off high voltage cables, high voltage equipment and power equipment as much as possible.

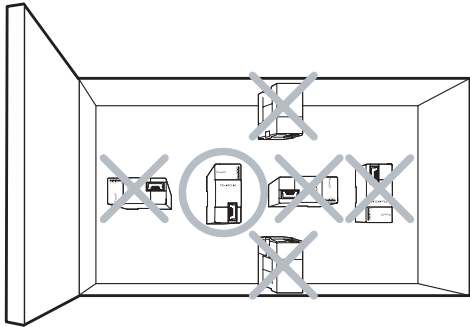

3.2 DIN rail installation

Align the upper DIN rail installation groove in the module with the DIN rail 1), and press the module in that status 2). When removing the module, pull the hook for installation downwards 3), then remove the module 4).

DIN rail mounting screw pitch

When installing the module to the DIN rail, tighten the mounting screws at the pitch of 200 mm (7.87") or less.

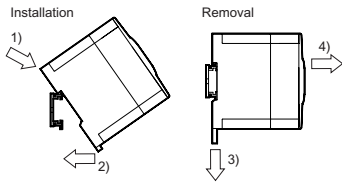

Applicable DIN rail | TH35-7.5Fe and TH35-7.5Al (conforming to JIS C2812)

3.3 Direct installation

Fix the master block on the panel surface by tightening M4 screws inserted in two (upper and lower) mounting holes provided on the master block. Install the module so that a clearance of 1 to 2mm (0.04" to 0.08") is assured for each module.

Applicable screw | M4 height: 16mm(0.63") or more
(Tightening torque range: 78 to 108 N·cm)

4. Connection of External Equipment

Connect the master block to a remote I/O unit or power adapter using the flat cable and the connector dedicated to CC-Link/LT.

- The connection order of the flat cable dedicated to CC-Link/LT has no relevance to the station No.
- Make sure to lay out the master block on one side of the trunk line.
- In the CC-Link/LT system, terminating resistors should be connected to both ends of the trunk line. At this time, connect the terminating resistor on the master block side to a position within 200 mm (7.87") from the master block.
- For the point of contact for the flat cable dedicated to CC-Link/LT, the connector to connect the flat cable and terminating resistors, refer to the homepage of the CC-Link Partner Association (CLPA) <http://www.cc-link.org/>.

5. Specifications

5.1 General specifications

Item	Specification				
Operating temperature	0 to 55°C (32 to 131°F)				
Storage temperature	-20 to 70°C (-4 to 158°F)				
Operating humidity	35 to 85%RH (Dew condensation should not be allowed.)				
Vibration resistance	Conforming to EN68-2-6	Direct mounting		Number of times of sweep 10 times in each of X, Y and Z directions (for 80 min)	
		Frequency	Acceleration		Half amplitude
		10 to 57Hz	—		0.075mm
		57 to 150Hz	9.8m/s ²		—
		DIN rail mounting			Half amplitude
Frequency	Acceleration	Half amplitude			
10 to 57Hz	—	0.035mm			
57 to 150Hz	4.9m/s ²	—			
Shock resistance	In conformance to EN 68-2-27 (147 m/s ² , working time: 11 ms, half sine wave, three times in each of X, Y and Z directions)				
Noise immunity	By noise simulator of noise voltage = 1,000 Vp-p, noise width = 1 μs, rising = 1 ns, cycle = 30 to 100 Hz				
Dielectric withstand voltage	500V AC for 1 min		In conformance to JEM-1021		
Isolation resistance	5 MΩ or more by 500V DC megger		Between case and PLC grounding terminal		
Operating ambience	Should be free from corrosive gas, flammable gas and conductive dusts. Do not use.				
Grounding	Grounding resistance 100Ω or less (Common grounding with strong electrical systems.)				

5.2 Network wiring specifications

Item	Specification			Remarks
Communication speed	2.5Mbps	625kbps	156kbps	--
Distance between stations	No restriction			--
Maximum number of modules connected in 1 drop line	8 units			--
Maximum trunk length	35m (114' 9")	100m (328' 1")	500m (1640' 5")	Cable length between terminating resistors
T-branch interval	No restriction			--
Maximum drop length	4m (13' 1")	16m (52' 5")	60m (196' 10")	Cable length per branch
Cumulative drop line length	15m (49' 2")	50m (164' 0")	200m (656' 2")	Sum of all drop lines

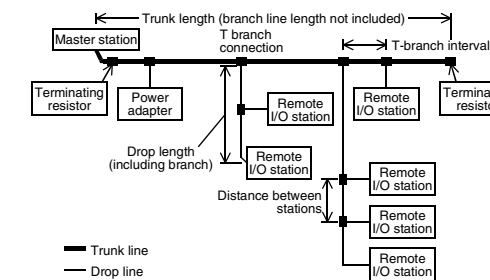

5.3 Performance specifications

Item	Specification		
Applicable PLC	FX1N/FX2N/FX2NC Series PLC (FX2NC-CNV4F is required when FX2NC Series PLC is connected.)		
Number of connectable master blocks	FX1N Series : Up to 4 ⁻¹ FX2N Series : Up to 8 ⁻² FX2NC Series : Up to 3 ⁻²		
Applicable point mode	4-point mode and 16-point mode (selectable by DIP switch)		
Control specifications	4-point mode		16-point mode
	Maximum number of link points Connected to FX1N Series PLC: 128 points Connected to FX2N/FX2NC Series PLC: 256 points (including I/O points in PLC in each case)		
	Number of link points per station () shows the number of link points when composite I/O module is used.		
Link scan time	32 stations	2.5Mbps	0.7ms
		625kbps	2.2ms
	64 stations	156kbps	8.0ms
		2.5Mbps	1.2ms
64 stations	625kbps	4.3ms	
	156kbps	15.6ms	
Communication speed	2.5 Mbps, 625 kbps and 156 kbps (selectable by DIP switch)		
Protocol	BITR method (Broadcastpolling + Interval Timed Response)		
Network topology	T-branch		
Error control method	CRC		
Number of connected stations	64 stations maximum		
Remote station numbers	1 to 64		
Master station connection position	Connected at end of trunk line		
RAS function	Communication error detection, automatic return to system, slave station disconnection and internal loop back diagnosis		
Connection cable	Dedicated flat cable (0.75 mm ² x 4)		
Number of occupied I/O points	8 points (fixed) + Number of connected remote I/O points		
Current consumption inside 5V DC	190 mA (Supplied from PLC via extension connector)		
24V DC power supply	Voltage	20.4V to 28.8V DC	
	Current consumption	25 mA	
	Initial current	35 mA	
Mass (weight)	0.15 kg (0.33 lbs)		

*1 When connected to the FX1N Series PLC, up to two FX2N-64CL-M units can be connected to each of the main unit and extension unit.

*2 FX2N-64CL-M draws 190mA from the 5V DC source. The total 5V consumption of all special function blocks connected to a main unit or extension unit must not exceed the 5V source capacity of the system. (Refer to the Hardware manual of the Programmable controller)

6. Outside Dimensions

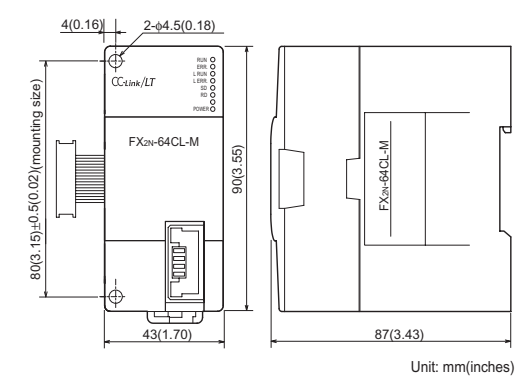

Unit: mm(inches)

Warranty

- Mitsubishi will not be held liable for damage caused by factors found not to be the cause of Mitsubishi; machine damage or lost profits caused by faults in the Mitsubishi products; damage, secondary damage, accident compensation caused by special factors unpredictable by Mitsubishi; damages to products other than Mitsubishi products; and to other utilities.
- For safe use
 - This product has been manufactured as a general-purpose part for general industries, and has not been designed or manufactured to be incorporated in a device or system used in purposes related to human life.
 - Before using the product for special purposes such as nuclear power, electric power, aerospace, medicine or passenger movement vehicles, consult with Mitsubishi.
 - This product has been manufactured under strict quality control. However when installing the product where major accidents or losses could occur if the product fails, install appropriate backup or failsafe functions in the system.

Country/Region	Sales office/Tel	Country/Region	Sales office/Tel
U.S.A	Mitsubishi Electric Automation Inc. 500 Corporate Woods Parkway Vernon Hills, IL 60061 Tel : +1-847-478-2100 MELCO-TEC Rep. Com.e Assessoria Tecnica Ltda. Av. Rio Branco, 123-15, and S/1507, Rio de Janeiro, RJ CEP 20040-005, Brazil Tel : +55-21-221-8343	China	Ryoden International Shanghai Ltd. 3F Blocks Building Automation Instrumentation Plaza 103 Cao Bao Rd. Shanghai 200233 China Tel : +86-21-6475-3228
Brazil	MELCO-TEC Rep. Com.e Assessoria Tecnica Ltda. Av. Rio Branco, 123-15, and S/1507, Rio de Janeiro, RJ CEP 20040-005, Brazil Tel : +55-21-221-8343	Taiwan	Setsuyu Enterprise Co., Ltd. 6F, No.105 Wu-Kung 3rd RD, Wu-Ku Hsiang, Taipei Hsin, Taiwan Tel : +886-2-2299-2499
Germany	Mitsubishi Electric Europe B.V. German Branch Golfner Strasse 8 D-40880 Ratingen, GERMANY Tel : +49-2102-486-0 Tel : +49-2102-486-0	Korea	HAN NEUNG TECHNO CO.LTD. 1F Dong Seo Game Channel Bldg, 660-11, Deungchon-dong Kangseok-ku, Seoul, Korea Tel : +82-2-3660-9552
U.K	Mitsubishi Electric Europe B.V. UK Branch Travelers Lane, Hatfield, Herts, AL10 8XB, UK Tel : +44-1707-276100 Mitsubishi Electric Europe B.V. Italian Branch Centro Dir. Colsoni, Pal. Persico - Ingr 2 Via Paracelso 12, 20041 Agrate B., Milano, Italy Tel:+39-039-60531	Singapore	Mitsubishi Electric Asia Pte, Ltd. 307 ALEXANDRIA ROAD #05-01/02, SINGAPORE 159943 Tel : +65-473-2480
Italy	Mitsubishi Electric Europe B.V. Italian Branch Centro Dir. Colsoni, Pal. Persico - Ingr 2 Via Paracelso 12, 20041 Agrate B., Milano, Italy Tel:+39-039-60531	Thailand	890/28,29,30 S.V.City Building,Office Tower 2, Floor 17-18 Rama 3 Road, Bangkokpungsa, Yamawa, Bangkok 10120 Tel : +66-2-682-6522
Spain	Mitsubishi Electric Europe B.V. Spanish Branch Carretera de Rubi 76-80 08190 - Sant Cugat del Valles, Barcelona, Spain Tel:+34-935-653135	Indonesia	PT. Autokemindo SUMBER MAKMUR Jl. Muara Karang Selatan Block4 Utara No.1 Kav. No.11 Kawasan Industri/ Pergudangan Jakarta - Utara 14440 Tel : +62-21-693-0833
South Africa	Circuit Breaker Industries LTD. Private Bag 2016, Isando 1600, Johannesburg, South Africa Tel : +27-11-928-2000	India	Messung Systems Pvt.Ltd. Electronic Sadan NO:111 Unit No15, M.I.D.C BHOSARI PUNE-411026 Tel : +91-20-7128927
Hong Kong	Ryoden Automation Ltd. 10th Floor, Manulife Tower, 169 Electric Road, North Point, HongKong Tel : +852-2887-8870	Australia	Mitsubishi Electric Australia Pty. Ltd. 348 Victoria Road, PostalBag, No.2, Rydalmere, N.S.W 2116, Australia Tel : +61-2-9684-7777

MITSUBISHI ELECTRIC CORPORATION
HEAD OFFICE : MITSUBISHI DENKI BLDG MARUNOUCHI TOKYO 100-8150 TELEX:24332 CABLE MELCO TOKYO
HIMEJI WORKS : 840, CHIVODA CHO, HIMEJI, JAPAN

When exported from Japan, this manual does not require application to the Ministry of Economy, Trade and Industry for service transaction permission.

Specifications are subject to change without notice



CC-Link/LT Master Block Model FX2N-64CL-M

Please read this manual thoroughly before starting to use the product and handle the product properly.

User's Manual (Hardware Volume)

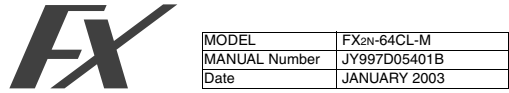

Table with 2 columns: Field (MODEL, MANUAL Number, Date) and Value (FX2N-64CL-M, JY997D05401B, JANUARY 2003)

SAFETY PRECAUTIONS

This manual describes the name of each part, outside dimensions and specifications of the CC-Link/LT master block for Mitsubishi Programmable Controller (PLC). For the design and construction of the CC-Link/LT system, refer to the CC-Link/LT Master Block Users Manual.

These SAFETY PRECAUTIONS are classified into two categories: "DANGER" and "CAUTION".

Depending on certain circumstances, procedures indicated by CAUTION may also be linked to serious ramifications. It is important to follow the directions for usage.

DESIGN PRECAUTIONS

Construct an interlock circuit in the sequence program so that the system works correctly using the communication information when an error in the data link occurs. If such an interlock circuit is not provided, accidents may be caused by erroneous output or malfunction.

Use the master block without applying any force on the master block and the flat cable dedicated to the CC-Link/LT. Otherwise, such cables may break or fail.

Shut down all phases of the power supply outside the master block, then attach or remove the master block. If the power is not disconnected at all phases an electric shock or serious damage to the product may occur.

Use the master block in the environment described in this manual. If the master block is used in an improper environment, then electrical shock, fire, malfunction, product damage or product deterioration may occur.

Securely fix the master block with DIN rail or mounting screws. When using mounting screws, securely tighten them within the specified torque range.

3. Handling Cautions

The master block can be attached by way of DIN rail or attached directly with screws. The installation procedure in each case is described below.

3.1 Installation direction
Do not install the master block on the floor surface, ceiling surface or in the horizontal direction. If the master block is installed in such a way, its temperature may rise.

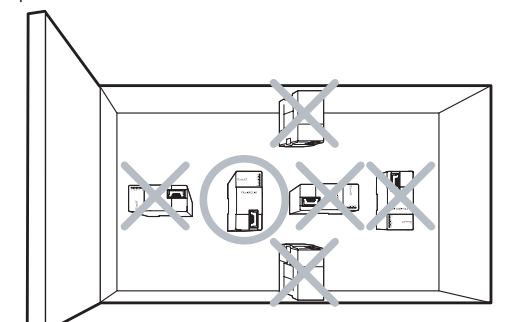

3.2 DIN rail installation

Align the upper DIN rail installation groove in the module with the DIN rail 1), and press the module in that status 2).

DIN rail mounting screw pitch

When installing the module to the DIN rail, tighten the mounting screws at the pitch of 200 mm (7.87") or less.

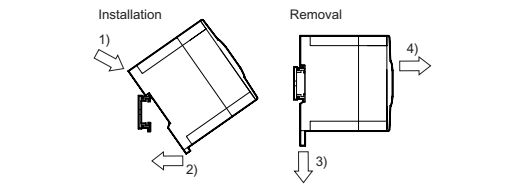

Applicable DIN rail TH35-7.5Fe and TH35-7.5Al (conforming to JIS C2812)

3.3 Direct installation

Fix the master block on the panel surface by tightening M4 screws inserted in two (upper and lower) mounting holes provided on the master block.

Applicable screw M4 height: 16mm(0.63") or more (Tightening torque range: 78 to 108 N-cm)

4. Connection of External Equipment

Connect the master block to a remote I/O unit or power adapter using the flat cable and the connector dedicated to CC-Link/LT.

- The connection order of the flat cable dedicated to CC-Link/LT has no relevance to the station No.
• Make sure to lay out the master block on one side of the trunk line.
• In the CC-Link/LT system, terminating resistors should be connected to both ends of the trunk line.
At this time, connect the terminating resistor on the master block side to a position within 200 mm (7.87") from the master block.
• For the point of contact for the flat cable dedicated to CC-Link/LT, the connector to connect the flat cable and terminating resistors, refer to the homepage of the CC-Link Partner Association (CLPA) "http://www.cc-link.org".

CAUTION
• Pay attention that foreign objects such as cuttings or wiring chips do not enter the master block. It may cause fire, product failure or malfunction.
• During installation and wiring works, adhere dust-proof sheets supplied together with the master block on the sides of the master block so that foreign objects such as cutting chips and wiring chips do not enter the inside. Otherwise, foreign objects may cause fire, failure or malfunction.
• Before operating the system, remove the dust-proof sheets so that heat can be released. It may cause fire, product failure or malfunction.

WIRING PRECAUTIONS

DANGER
• Shut down all power supplies, before starting the wiring work. If the power is not disconnected from all sources an electric shock or serious product damage may occur.

CAUTION
• CC-Link/LT network wiring uses the flat cable dedicated to the CC-Link/LT specified by CC-Link Partner Association (CLPA), and perform wiring in accordance with the specifications described in this manual.
• Do not bind the flat cable dedicated to CC-Link/LT together with major circuits or power cables. Keep the dedicated flat cable used or if wiring is performed in a method not conforming to the specifications, normal data transmission cannot be assured.
• Do not bind the flat cable dedicated to CC-Link/LT together with major circuits or power cables. Keep the dedicated flat cable used or if wiring is performed in a method not conforming to the specifications, normal data transmission cannot be assured.
• Accommodate the flat cable dedicated to CC-Link/LT inside a duct, or fix it with clamps.
If the dedicated flat cable is loose or is pulled for movement or carelessness, the master block and the dedicated flat cable may be damaged or malfunction due to imperfect connection.
• Correctly wire the master block while confirming the rated voltage and terminal arrangement of the master block. It may cause fire or product failure.
• Hold the connector area when disconnecting the flat cable dedicated to CC-Link/LT from the master block.
If the cable area is pulled, the master block or the dedicated cable may be damaged or malfunction.

STARTING AND MAINTENANCE PRECAUTIONS
DANGER
• Do not touch the terminals when the power is ON. It may cause an electric shock or malfunction.
• Make sure to shut down all phases of the power supply outside the master block before starting cleaning. If all phases of the power supply are not shut down, the master block may be seriously damaged or malfunction.

CAUTION
• Do not disassemble or modify the master block. Doing so may cause failure, malfunction, injury, or fire.
• The case of the master block is made of resin. Do not drop or apply strong impacts to the master block.

DISPOSAL PRECAUTIONS
DANGER
• When disposing of this product, treat it as industrial waste.

Notification of CE marking
This notification does not guarantee that an entire mechanical module produced in accordance with the contents of the notification comply with the following standards. Compliance to EMC standards of the entire mechanical module should be checked by the user / manufacturer.
Standards with which this product complies
Type : Programmable Controller (Open Type Equipment)
Models : Products manufactured from February 1st, 2003.
Electromagnetic Compatibility Standards (EMC)
EN61000-6-4:2001
Electromagnetic compatibility
- Generic standards - Emission standard for industrial environment
Following item is examined:
- Radiated Emissions
EN61131-2:1994 Programmable controllers
/A11: 1996 - Equipment requirements and tests
/A12: 2000
Following items are examined:
- RF Immunity - Fast transients
- ESD
- Damped oscillatory wave
For more details please contact the local Mitsubishi Electric sales site.
- Notes For compliance to EMC regulation.
It is necessary to install the FX2N-64CL-M in a shielded metal control panel.

5. Specifications

Table with 2 columns: Item and Specification. Includes Operating temperature, Storage temperature, Operating humidity, Vibration resistance, Shock resistance, Noise immunity, Dielectric withstand voltage, Isolation resistance, Operating ambience, Grounding.

5.2 Network wiring specifications

Table with 3 columns: Item, Specification, Remarks. Includes Communication speed, Distance between stations, Maximum number of modules connected in 1 drop line, Maximum trunk length, T-branch interval, Maximum drop length, Cumulative drop line length.

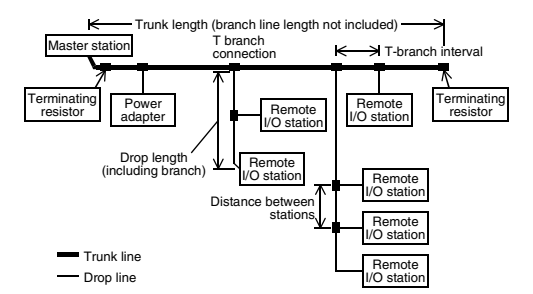

Associated Manuals

Table with 3 columns: Manual name, Manual No., Description. Lists CC-Link/LT Master Block Model FX2N-64CL-M User's Manual (Detailed Volume) (Japanese only).

1. Product Outline

The CC-Link/LT master block FX2N-64CL-M can be connected to the FX Series PLC. By using this master block, the CC-Link/LT system can be constructed while setting the FX Series PLC as the master station.

2. Part Name and Setting

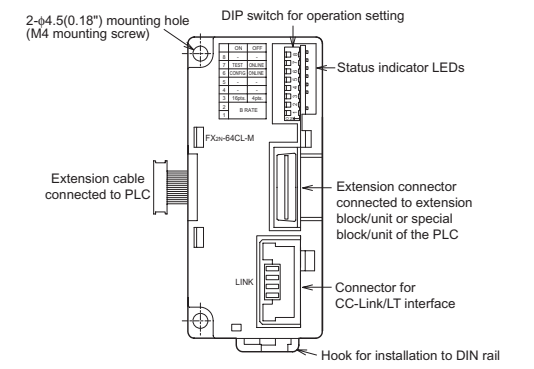

Table with 2 columns: Name and Description. Details the behavior of Status indicator LEDs for POWER, RUN, and ERROR conditions.

5.3 Performance specifications

Table with 2 columns: Item and Specification. Details performance metrics like Applicable PLC, Number of connectable master blocks, Communication speed, Link scan time, etc.

*1 When connected to the FX1N Series PLC, up to two FX2N-64CL-M units can be connected to each of the main unit and extension unit.
*2 FX2N-64CL-M draws 190mA from the 5V DC source.

Table with 2 columns: Name and Description. Details the behavior of Status indicator LEDs for L RUN, L ERR, SD, RD, and Interface settings.

- Factory default, all bits of the DIP switch are set OFF.
• The Test mode is selected when both the CONFIG and TEST mode are set ON simultaneously.
• For each setting, the status at the time of power ON is valid. (If a setting is changed after the power is ON, such a change is invalid.)
CONFIGMODE
• BFM #32 (20h) to #95 (5Fh) changed value while online will cause a L ERR.
• No remote module attached during power ON will result in no L ERR.
• Remote module removed during operation will result in no L ERR.

6. Outside Dimensions

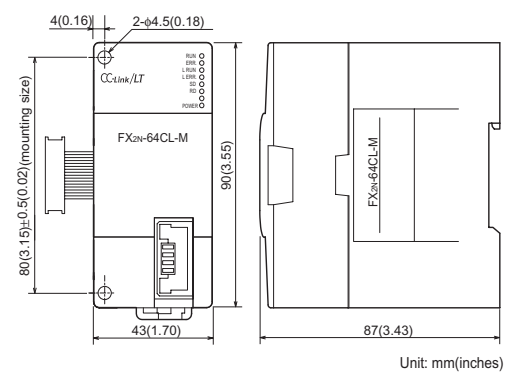

Warranty

Mitsubishi will not be held liable for damage caused by factors found not to be the cause of Mitsubishi; machine damage or lost profits caused by faults in the Mitsubishi products; damage, secondary damage, accident compensation caused by special factors unpredictable by Mitsubishi; damages to products other than Mitsubishi products; and to other duties.

For safe use

- This product has been manufactured as a general-purpose part for general industries, and has not been designed or manufactured to be incorporated in a device or system used in purposes related to human life.
• Before using the product for special purposes such as nuclear power, electric power, aerospace, medicine or passenger movement vehicles, consult with Mitsubishi.
• This product has been manufactured under strict quality control. However when installing the product where major accidents or losses could occur if the product fails, install appropriate backup or fail-safe functions in the system.

Table with 2 columns: Country/Region and Sales office/Tel. Lists contact information for various countries including USA, Brazil, Germany, UK, Italy, Spain, South Africa, Hong Kong, etc.