

MELSEC FX series

Programmable Controllers

User's Manual
(FX2N-32CAN Communication Module)

FX2N

FX₂N-32CAN Communication Module

USER'S MANUAL

Manual number : JY992D92801

Manual revision : B

Date : MAY 2006

This manual confers no industrial property rights or any rights of any other kind, nor does it confer any patent licenses. Mitsubishi Electric Corporation cannot be held responsible for any problems involving industrial property rights which may occur as a result of using the contents noted in this manual.

Guidelines for the Safety of the User and Protection of the Programmable Controller

This manual provides information for the use of the FX2N-32CAN Communication Module. The manual has been written to be used by trained and competent personnel. The definition of such a person or persons is as follows;

- a) Any engineer who is responsible for the planning, design and construction of automatic equipment using the product associated with this manual should be of a competent nature, trained and qualified to the local and national standards required to fulfill that role. These engineers should be fully aware of all aspects of safety with regards to automated equipment.
- b) Any commissioning or service engineer must be of a competent nature, trained and qualified to the local and national standards required to fulfill that job. These engineers should also be trained in the use and maintenance of the completed product. This includes being completely familiar with all associated documentation for the said product. All maintenance should be carried out in accordance with established safety practices.
- c) All operators of the completed equipment should be trained to use that product in a safe and coordinated manner in compliance to established safety practices. The operators should also be familiar with documentation which is connected with the actual operation of the completed equipment.

Note : Note: the term ‘completed equipment’ refers to a third party constructed device which contains or uses the product associated with this manual.

Notes on the Symbols Used in this Manual

At various times through out this manual certain symbols will be used to highlight points of information which are intended to ensure the users personal safety and protect the integrity of equipment. Whenever any of the following symbols are encountered its associated note must be read and understood. Each of the symbols used will now be listed with a brief description of its meaning.

Hardware Warnings



- 1) Indicates that the identified danger **WILL** cause physical and property damage.



- 2) Indicates that the identified danger could **POSSIBLY** cause physical and property damage.



- 3) Indicates a point of further interest or further explanation.

Software Warnings



- 4) Indicates special care must be taken when using this element of software.



- 5) Indicates a special point which the user of the associate software element should be aware of.



- 6) Indicates a point of interest or further explanation.

- Under no circumstances will Mitsubishi Electric be liable responsible for any consequential damage that may arise as a result of the installation or use of this equipment.
- All examples and diagrams shown in this manual are intended only as an aid to understanding the text, not to guarantee operation. Mitsubishi Electric will accept no responsibility for actual use of the product based on these illustrative examples.
- Owing to the very great variety in possible application of this equipment, you must satisfy yourself as to its suitability for your specific application.

Note Concerning the CE Marking

This document does not guarantee that a mechanical system including this product will comply with the following standards. Compliance to EMC standards of the entire mechanical system should be checked by the user / manufacturer. Compliance to LVD standards of the entire mechanical system should be checked by the user / manufacturer.

EMC

The following products have shown compliance through direct testing (of the identified standards below) and design analysis (through the creation of a technical construction file) to the European Directive for Electromagnetic Compatibility (89/336/EEC) when used as directed by the appropriate documentation. Refer to a manual or related material of each product other than the following.

Type : Programmable Controller (Open Type Equipment)

Models : FX_{2N}-32CAN manufactured

from November 1st, 2001 to April 30th, 2006 are
compliant with EN50081-2 and EN61131-2:1994+A11:1996
after May 1st, 2006 are compliant with EN61131-2:2003

Standard	Remark
EN50081-2:1993 Electromagnetic compatibility - Generic emission standard Industrial environment	Compliance with all relevant aspects of the standard. (Radiated Emissions)
EN61131-2:1994 Programmable controllers /A11:1996 - Equipment requirements and tests	Compliance with all relevant aspects of the standard. (RF Immunity, Fast Transients , ESD and Damped oscillatory wave)
EN61131-2:2003 Programmable controllers - Equipment requirements and tests	Compliance with all relevant aspects of the standard. (Radiated Emissions, Mains Terminal Voltage Emissions, RF immunity, Fast Transients, ESD, Surge, Voltage drops and interruptions, Conducted and Power magnetic fields)

For more details, please contact the local Mitsubishi Electric sales site.

- Note for using the FX_{2N}-32CAN

For compliance to EC EMC directive, install the FX_{2N} main unit, extension unit/block and the FX_{2N}-32CAN in a shielded metal cabinet.

Table of Contents

Guideline of Safty.....	V
1. Introduction.....	1-1
1.1 Associated Manuals	1-1
1.2 General Names and Abbreviations.....	1-2
2. Overview	2-1
2.1 Overview of the CANopen Network.....	2-1
2.2 Overview of FX2N-32CAN Communication Module.....	2-1
2.3 Characteristics.....	2-2
2.3.1 Communication with other CANopen Nodes.....	2-2
2.3.2 The Object Dictionary.....	2-2
2.3.3 SDO Command	2-2
2.3.4 The Command Interface.....	2-2
2.3.5 Node Guarding	2-2
3. Specification	3-1
3.1 Environmental/Standards Specifications	3-1
3.2 Power Supply Specifications	3-1
3.3 Performance Specification.....	3-2
4. Buffer Memory Structure/Parameter Setup	4-1
4.1 Basic Buffer Memory Structure, BFM0 ~ BFM31	4-1
4.2 Buffer Memory Functions	4-1
4.2.1 Data Transfer Locations, BFMs 0~19 and 100~199	4-1
4.2.2 The Data Exchange Mode, BFM 20	4-1
4.2.3 Setting the Baud Rate, BFM 24.....	4-2
4.2.4 Reading the Communication Status, BFM 25	4-2
4.2.5 The Watch Dog Timer Setting, BFM 26	4-3
4.2.6 The Node Address, BFM 27	4-3
4.2.7 Error Staus, BFM 29.....	4-4
4.2.8 BFM Data Memory Backup	4-4
4.3 Extended BFM Structure, BFM32 ~ BFM32767	4-5
5. The Object Dictionary	5-1
5.1 BFM access to the Object Dictionary - Write TO.....	5-1
5.2 BFM access to the Object Dictionary - Read FROM	5-3
5.3 CANopen Object Dictionary Structure	5-4
5.3.1 The General Setup	5-4
5.3.2 The Detailed Object Dictionary Contents (According to DS-301*)	5-4

6. The Command Interface.....	6-1
6.1 SDO Read Request.....	6-1
6.2 SDO Write Request.....	6-2
6.3 Layer 2 Messages.....	6-3
6.3.1 The PDO Remote Transmission Request.....	6-4
6.4 Error Messages.....	6-5
6.4.1 General Error Messages.....	6-5
6.4.2 Local SDO Error Codes (BFM1001 = 3).....	6-6
6.4.3 Remote SDO Error Codes (BFM1001 = 3).....	6-6
6.4.4 Unknown Command Used (BFM1001 = 100).....	6-7
6.4.5 Queue was not available (BFM1001 = 8FFFF hex).....	6-7
6.4.6 Command or Parameter Change while CIF was busy (BFM1001 = FFFF hex).....	6-7
6.4.7 The Clear/Reset "CIF was busy" Error.....	6-7
6.4.8 CIF Internal Error (BFM1001 = 200 hex).....	6-8
7. The Mapping Modes.....	7-1
7.1 Factory Default Mapping/Mode 0 Mapping.....	7-2
7.2 Mode A Mapping.....	7-2
7.3 Mode B Mapping.....	7-3
7.3.1 Prepare the PDO Mapping Table.....	7-3
7.3.2 The Source Command.....	7-5
7.3.3 The Destination Parameter.....	7-5
7.3.4 Assign Additional COB-IDs to the Local Node.....	7-6
7.3.5 The End of the Parameter Table.....	7-6
7.4 PDO Mapping Table Overviews.....	7-7
7.4.1 Tx-PDO Mapping Table.....	7-7
7.4.2 Rx-PDO Mapping Table.....	7-8
7.4.3 Mode B Mapping Errors.....	7-9
7.4.4 Source Parameter Errors.....	7-9
7.4.5 Destination Parameter Errors.....	7-10
7.4.6 Other Errors.....	7-10
8. Node Guarding.....	8-1
8.1 CIF/BFM Structure for Slave Guarding Assignment.....	8-1
8.2 Node Guarding Parameter Settings.....	8-1
8.2.1 Slave Number.....	8-1
8.2.2 Services Requested.....	8-2
8.2.3 Guard Time.....	8-2
8.2.4 Number of Retries.....	8-2
8.2.5 End of Parameter Table.....	8-2
8.2.6 Parameter Errors.....	8-2
8.2.7 Read Guarding Status.....	8-3
8.2.8 Reset Guarding Status Latch.....	8-4
9. Emergency Messages.....	9-1
9.1 Read Emergency Message Buffers.....	9-1
9.2 Send an Emergency Message.....	9-3

1. Introduction

1.1 Associated Manuals

Table 1.1: Manual List

	Manual name	Manual number	Description
⊙	FX _{2N} -32CAN Communication Module Hardware Manual	JY992D92901 (packed with product)	Describes the wiring, installation, parts, and handling of the CANopen Communication Module.
⊙	FX _{1S} /FX _{1N} /FX _{2N} /FX _{2NC} Programming Manual II	JY992D88101 (sent separately)	Explains the instructions in the FX _{1S} /FX _{1N} / FX _{2N} /FX _{2NC} Series PLC.
○	FX _{1N} Hardware Manual	JY992D89301 (packed with product)	Describes the contents related to the hardware such as specification, wiring and mounting of the FX _{1N} Series PLC.
○	FX _{2N} Hardware Manual	JY992D66301 (packed with product)	Describes the hardware specifications such as the wiring and mounting of the FX _{2N} Series PLC.
○	FX _{2NC} Hardware Manual	JY992D76401 (packed with product)	Describes the hardware specifications such as the wiring and mounting of the FX _{2NC} Series PLC.

⊙: Refer to these manuals

○: Refer to the manual required depending on the equipment used

1.2 General Names and Abbreviations

Unless otherwise specified, this manual uses the general names and abbreviations shown in the table below to describe the FX2N-32CAN Communication Module.

Table 1.2: Vocabulary List

General name/ abbreviation	Description
FX _{2N} -32CAN	Abbreviation of the FX _{2N} -32CAN Communication Module.
Cyclic transmission	Transmission method to periodically communicate the contents of remote I/Os and remote registers.
Network Management Node	Node which controls the data link system for the CANopen network. One Network Manager station is required per system.
Rx-PDO	<u>R</u> ecieve <u>P</u> rocess <u>D</u> ata <u>O</u> bjects are data read from other nodes via the CAN bus.
Tx-PDO	<u>T</u> ransmit <u>P</u> rocess <u>D</u> ata <u>O</u> bjects are the data sent to other nodes via the CAN bus.
CIF	The <u>C</u> ommand <u>I</u> nterface is the FX2N-32CAN tool used to perform actions such as to set parameters, execute commands, establish communication connections, access the CANopen Object Dictionary, and read error messages.
COB-ID	The <u>C</u> AN <u>O</u> bject <u>I</u> D number is a unique identifying number to distinguish between different messages on the CAN bus (e.g. PDO, SDO, NMT, SYNC, EMCY messages)
Mapping Mode 0	Base Configuration where 4 Rx-PDOs and 4 Tx-PDOs are given BFM assignments for each FX2N-32CAN node according to the pre-defined connection set of CANopen.
Mapping Mode A	Mitsubishi Electric defined configuration for the FX2N-32CAN module that defines the relationship between up to eight FX2N-32CAN nodes, the node BFMs, and the Rx-PDOs and Tx-PDOs. This mode is very convenient if every node is an FX2N-32CAN module.
Mapping Mode B	Configuration mode that allows specific Rx-PDOs and Tx-PDOs to be matched on a node by node basis.

2. Overview

This chapter describes the overview of the FX2N-32CAN Communication Module for the FX1N/2N(c) Series PLC.

The Controller Area Network (CAN used hereafter in this manual) is a serial bus system especially suited for networking "intelligent" devices as well as sensors and actuators within a system or sub-system.

2.1 Overview of the CANopen Network

The CANopen protocol provides a system for transferring serial messages between different nodes via the CAN bus.

- 1) Simple, relatively high speed communication can be accomplished with modules that handle the ON/OFF data such as I/Os or numeric data.
- 2) All CAN nodes are able to transmit data and several nodes can make a request to the CAN bus simultaneously.
- 3) Connections can be made to different types of devices made by partner manufacturers giving flexibility to the system.
- 4) Messages can be prioritized for transfer to the CAN Bus.

2.2 Overview of FX2N-32CAN Communication Module

The FX2N-32CAN Communication Module is a special extension block which allows an FX1N/2N(c) PLC to transfer/receive data from other nodes on the CAN bus.

- 1) CANopen ready I/O stations and device stations can be connected to the CAN bus and information can be transmitted to the FX2N-32CAN module and FX Series PLC.
- 2) By using the FX2N-32CAN module, two or more FX1N/2N(c) Series PLCs can be connected via the CAN bus to configure a simple distributed system.

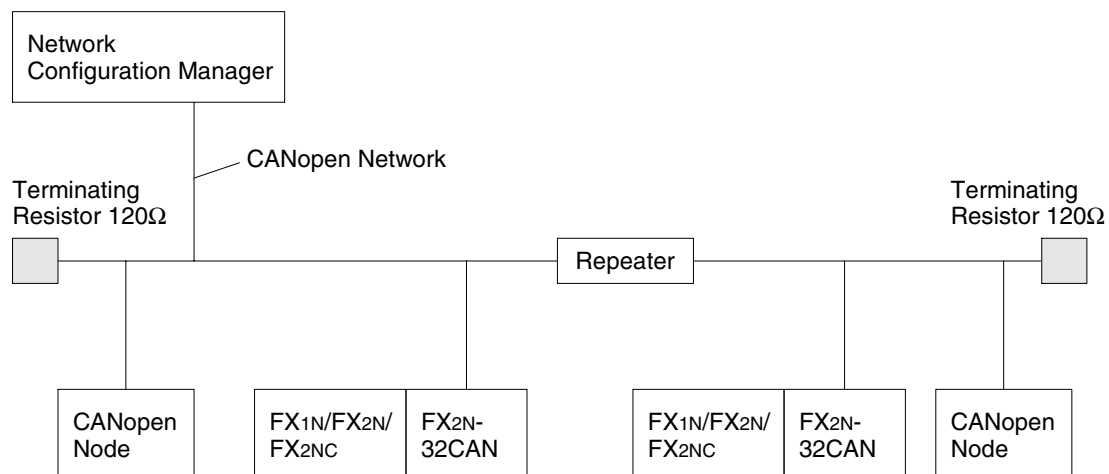

Network Manager Node: Station which controls the data link system

CANopen Node : Node for transferring or receiving data from the CAN bus.

2.3 Characteristics

This section describes the characteristics of the CAN bus, communication with other CANopen nodes, and some of the special features available in the CANopen protocol.

2.3.1 Communication with other CANopen Nodes

All nodes on the CAN network can write data to the all the other nodes on the network. Each piece of data has a unique identifying number that is read by the receiving nodes to determine whether that data should be kept in the receiving nodes' Buffer Memory.

The FX2N-32CAN module has separate buffer memories for writing TO and reading FROM the CAN bus. These Buffer Memories are accessed by FROM/TO commands of the PLC.

2.3.2 The Object Dictionary

The Object Dictionary is a kind of indexed storage system that contains data, device parameters, CANopen feature setup data, instruction triggers, and other information necessary to configure and operate the CANopen protocol.

2.3.3 SDO Command

The Service Data Object Command can be used to read/write data to the Object Dictionary. This command can be used to set network parameters and also to initiate CANopen functionality.

2.3.4 The Command Interface

The Command Interface is a set of Buffer Memories that is used when using the SDO Command. The data placed in these BFM's is used to access the parameter setup of the Object Dictionary.

2.3.5 Node Guarding

The nodes on a CAN bus can be checked for their communication status at user defined intervals. If a problem occurs or communication is blocked for some reason, an error message will be generated to alert the user to the situation.

3. Specification

3.1 Environmental/Standards Specifications

Table 3.1: Environmental/Standards Specifications

Item	Description
Environmental specifications excluding dielectric withstand voltage	Same as those of the main unit.
Dielectric Withstand Voltage	500 V AC > 1 min, tested between signal line and ground
CAN Standard	ISO 11898/1993
CANopen Standard by CiA	DS-301 Version 3.0
Additional CANopen Features	NMT, Guarding, and Guarding request based on DS-302 V2.0. Network Variables based on DS-405 V1.0

3.2 Power Supply Specifications

Table 3.2: Power Supply Specifications

Item	Description
External Power Supply	None
Internal Current Consumption	130 mA at 5 V DC

3.3 Performance Specification

Table 3.3: Performance Specifications

Item	Specification
Applicable function	CANopen Node
Applicable PLC	FX1N, FX2N(c)
Transmission speed	Selectable (Write to BFM 24): 10 kBd, 20 kBd, 50 kBd, 125 kBd, 250 kBd, 500 kBd, 800 kBd, 1 MBd
Node number	Selectable from 1~127, (Write to BFM 26)
Maximum total cable length (maximum transmission distance)	5000 m maximum Varies depending on the transmission speed.
Maximum number of connected modules	The node address can be set from 1 ~ 127. A total of 30 nodes can be connected on each bus. By the use of repeaters or bridges, the total number can be extended up to 127 nodes.
Communication method	Cyclic or Event Driven
Transmission path type	CAN Bus (RS-485)
Connection cable	The cable should conform to ISO11898/1993. Recommended is a shielded 2 X 2 twisted pair cable with an impedance of about 120 ohm.
Connectable PLC	FX _{1N} , FX _{2N(c)} Series PLC
Number of occupied I/O points	8 I/O points of FX Series PLC (Selectable from Inputs or Outputs)
Communication with PLC	By FROM/TO instructions via the buffer memory
Operation indication	<p>RUN : Lit green when module is exchanging information with the CANopen network.</p> <p>FROM/TO: Lit green when module is receiving FROM/TO commands.</p> <p>Tx/Rx : Lit green when CAN-interface system is in normal operation.</p> <p>ERROR : Lit red when communication, overflow, or general error occurs.</p> <p>POWER : Lit green when the 5VDC power is supplied from main unit.</p>

4. Buffer Memory Structure/Parameter Setup

This chapter describes Buffer Memory Structure of the FX2N-32CAN module and the how to set the parameters associated with the CANopen protocol.

4.1 Basic Buffer Memory Structure, BFM0 ~ BFM31

Table 4.1: Buffer Memory Structure, BFM0 - BFM31

BFM#	READ (FROM)	WRITE (TO)
BFM0	Received data (Section 4.2.1-2)	Data to Transmit (Section 4.2.1-2)
BFM1	Received data (Section 4.2.1-2)	Data to Transmit (Section 4.2.1-2)
⋮	⋮	⋮
BFM19	Received data (Section 4.2.1-2)	Data to Transmit (Section 4.2.1-2)
BFM20	Data exchange status bit (Section 4.2.2)	Data exchange control bit (Section 4.2.2)
BFM21	Reserved	Reserved
BFM22	Reserved	Reserved
BFM23	Reserved	Reserved
BFM24	Read baud rate (Section 4.2.3)	Set baud rate (Section 4.2.3, default 10kBd)
BFM25	Module communication status (Section 4.2.4)	Reset + CANopen restart command (Section 4.2.4)
BFM26	Read FROM/TO watchdog timer reload value, "default = 20" equals 200ms. (Section 4.2.5)	Set FROM/TO watchdog timer reload value, "default = 20" equals 200ms. (Section 4.2.5)
BFM27	Read node address (Section 4.2.6)	Set node address, default = 127. (Section 4.2.6)
BFM28	Reserved	Reserved
BFM29	Error status (Section 4.2.7)	Reset latched error status (Section 4.2.7)
BFM30	Module code (K7100)	(Read only)
BFM31	Reserved	Reserved

4.2 Buffer Memory Functions

4.2.1 Data Transfer Locations, BFMs 0~19 and 100~199

These Buffer memory locations in the FX2N-32CAN module are used to receive from and transfer data to the CAN bus.

4.2.2 The Data Exchange Mode, BFM 20

On read access, BFM20 contains a status bit for data exchange. If bit0 is "1", the module is in data exchange mode and the received data are valid (no CAN error occurred). If bit0 is "0", the module is not in data exchange mode.

On write access, BFM20 acts as the data exchange control signal. To ensure that the FX2N-32CAN module can handle the PDO data in a consistent way, it is absolutely necessary to write a "1" to this BFM before reading Rx PDO data (FROM) and after writing Tx-PDO data (TO) to the module. The data exchange control signal ensures, by internal buffer exchange, that TO data from the PLC will be transmitted within the same corresponding Tx-PDO at the same time.

TO data will only be sent to the CAN bus after a write access to BFM20 (data = 1).

As long as the reading of the previous data is not finished and a new exchange command to BFM20 has not been sent, FROM data from the CAN bus will not be (partially) overwritten by further Rx PDOs with the same ID.

If the CANopen module is in data exchange mode, the received PDO data (Rx-PDO) from other nodes can be read by the FX2N(C)/FX1N PLC by using a FROM instruction and the transmit PDO data (Tx-PDO) can be written to the module and sent to the network by using a TO instruction.

4.2.3 Setting the Baud Rate, BFM 24

BFM24 contains the current baud rate setting of the FX2N-32CAN module as shown in Table 4.2 below. The baud rate can be set by writing TO BFM24 and the baud rate must be equal for all nodes on the CANopen network.

Table 4.2: Baud Rate Settings

Baud Rate	BFM24 Value
10 kBd	10
20 kBd	20
50 kBd	50
125 kBd	125
250 kBd	250
500 kBd	500
800 kBd	800
1000 kBd	1000

4.2.4 Reading the Communication Status, BFM 25

Read the CANopen module's communication status from BFM 25 per the table below.

Table 4.3: Communication Status

Bit	On	Off
b0: module online/offline	module online	module offline
b1 ~ b7: reserved		
b9, b8: CANopen network state	00 _b = Prepared State 01 _b = Pre-operational State 10 _b = Operational State 11 _b = Not Possible	
b10 ~ b15: reserved		

Note: On write access, BFM25 contains the command flags to reset the FX2N-32CAN and to restart the CANopen stack.

Table 4.4: CANopen Stack Reset

Bit	On	Off
b0: restart command	CANopen stack will be restarted	Normal operation
b1 ~ b15: reserved		

The restart command can be used after the baud rate (BFM24) or the node address (BFM27) was changed. By setting B0 to "1" (use the pulse instruction), the module can be forced to go offline and to restart with the new settings without switching off the power of the host PLC.

4.2.5 The Watch Dog Timer Setting, BFM 26

The Watch Dog Timer setting is stored in BFM 26 in units of 10 ms. A WDT error will occur if there is no FROM or TO instruction to any BFM for the time specified. After the WDT has expired, it must be reset by writing the current or a new value to BFM26. When the value 0 is written to BFM26, the FROM/TO watchdog timer is disabled.

During normal operation as soon as the module receives a FROM or TO instruction, the WDT will reset to time zero.

Note: No Emergency Message will be transmitted if the WDT is disabled and the FROM/TO communication stops and the FX2N-32CAN module is in operational mode.

4.2.6 The Node Address, BFM 27

The CANopen node supports setting of the node address by the FX2N(C)/FX1N PLC via the TO instruction. The actual address is displayed in BFM27. The Node address must be set for communication to take place via the CAN bus.

In case of an address change by TO instruction, the new address value (1...127_d) must be written to BFM27. The new address will only become effective after a power down of the host PLC or after a restart command written to BFM25.

4.2.7 Error Status, BFM 29

BFM29 reflects the error status of the module. Bit 7 shows the status of the FROM/TO watchdog timer (see section 4.1.7, BFM 26). In case of a watchdog timer error (b7 is ON) an external emergency message will be sent to the CANopen network if the module is in operational mode.

When the value 0 is written to BFM26, the FROM/TO watchdog timer is disabled and b7 of BFM29 will never become "1".

Table 4.5: Error Bit Description for BFM 29

Bit	On	Off
b0: general error	This bit is ON if b2, b3 or b4 are On	No general error
b1: reserved		
b2: power error	Power supply error	Power supply normal
b3: CAN bus off error	CAN bus off error	
b4:EEPROM/flash memory error	Data in EEPROM or flash memory is corrupted	EEPROM and flash memory data normal
b5, b6: reserved		
b7: FROM/TO watchdog timer (reset by writing a value to BFM26)	No FROM/TO instruction received (for the time specified in BFM26)	FROM/TO instructions received regularly
b8: Data queue overflow	Data could not be written to internal queue	No data queue overflow
b9: Command queue or event queue overflow	Data could not be written to internal command queue or event queue	No command queue or event queue overflow
b10: CANopen guarding error	CANopen guarding error occurred	No CANopen guarding error occurred
b11: Baud rate change error	New baud rate not valid, no change	Set baud rate valid
b12: Address change error	New address not valid, no change	Address is valid
b13: CANopen emergency	CANopen emergency occurred	No emergency exists
b14: CAN error passive state	CAN error passive	CAN error active
b15: Reserved		

NOTE:

1. The error bits b2, b8, b9, and b14 are latched and must be reset from the PLC by writing "0" to the appropriate bit in BFM29. By writing "0" to all of BFM29, all latched error flags will be cleared.
2. All other error flags will be reset automatically as soon as the corresponding error has been solved.

4.2.8 BFM Data Memory Backup

The data in BFM24, 26, and 27 are kept by EEPROM.

4.3 Extended BFM Structure, BFM32 ~ BFM32767

Table 4.6: Extended BFM Structure

BFM#	READ (FROM)	WRITE (TO)
BFM32 ~ BFM99	Reserved	Reserved
BFM100 ~ BFM199	Received Output Data	Transmit Data
BFM200 ~ BFM999	Reserved	Reserved
BFM1000 ~ BFM1066	Module Command Interface	Module Command Interface
BFM1067 ~ BFM32767	Reserved	Reserved

The Command Interface (CIF) offers the possibility to send commands directly to the CANopen module. This command interface can be used to manipulate and control all items in the object dictionary, to send and receive SDO messages, to send network management messages, or to send emergency messages.

MEMO

5. The Object Dictionary

The Object Dictionary is a structure for data organization within the CAN bus. The data within the Object Dictionary can be used to set CAN bus parameters, initialize special functions, control data flow, to store data in many formats or send emergency messages.

The Object Dictionary address consists of an Index and Sub-Index for data Read/Write. Different indexes are used depending upon the type of data to store - unsigned 8 bit, signed 8 bit, unsigned 16 bit, signed 16 bit, unsigned 32 bit, signed 32 bit, or 32 bit floating point.

The information contained in Sections 5.1 and 5.2 detail how the FX2N-32CAN module BFMs can transfer information TO/FROM the Object Dictionary Mapping. For the complete structure of the CANopen Object Dictionary, please go to the CAN-in-Automation website at <http://www.can-cia.de>.

5.1 BFM access to the Object Dictionary - Write TO

Use the TO instruction to write data to the following locations.

Table 5.1: CAN bus Object Dictionary - TO Instruction Access

Index A240h float 32 bit object	Index A200h unsigned 32 bit object	Index A1C0h signed 32 bit object	Index A100h unsigned 16 bit object	Index A0C0h signed 16 bit object	Index A040h unsigned 8 bit object	Index A000h signed 8 bit object	BFM (TO access)			
sub- index	sub- index	sub- index	sub- index	sub- index	sub- index	sub- index				
01h	01h	01h	01h	01h	01h	01h	BFM 0, lower 8 bit			
					02h	02h	BFM 0, higher 8 bit			
			02h	02h	02h	02h	02h	03h	03h	BFM 1, lower 8 bit
								04h	04h	BFM 1, higher 8 bit
02h	02h	02h	03h	03h	05h	05h	BFM 2, lower 8 bit			
					06h	06h	BFM 2, higher 8 bit			
			04h	04h	04h	04h	04h	07h	07h	BFM 3, lower 8 bit
								08h	08h	BFM 3, higher 8 bit
03h	03h	03h	05h	05h	09h	09h	BFM 4, lower 8 bit			
					0Ah	0Ah	BFM 4, higher 8 bit			
			06h	06h	06h	06h	06h	0Bh	0Bh	BFM 5, lower 8 bit
								0Ch	0Ch	BFM 5, higher 8 bit
.			
.			
.			
0Ah	0Ah	0Ah	13h	13h	25h	25h	BFM 18 lower 8 bit			
					26h	26h	BFM 18 higher 8 bit			
			14h	14h	14h	14h	14h	27h	27h	BFM 19, lower 8 bit
								28h	28h	BFM 19, higher 8 bit

Table 5.1: CAN bus Object Dictionary - TO Instruction Access

Index A240h float 32 bit object	Index A200h unsigned 32 bit object	Index A1C0h signed 32 bit object	Index A100h unsigned 16 bit object	Index A0C0h signed 16 bit object	Index A040h unsigned 8 bit object	Index A000h signed 8 bit object	BFM (TO access)
0Bh	0Bh	0Bh	15h	15h	29h	29h	BFM 100, lower 8 bit
					2Ah	2Ah	BFM 100, higher 8 bit
			16h	16h	2Bh	2Bh	BFM 101, lower 8 bit
					2Ch	2Ch	BFM 101, higher 8 bit
.
.
.
3Ch	3Ch	3Ch	77h	77h	EDh	EDh	BFM 198, lower 8 bit
					EEd	EEd	BFM 198, higher 8 bit
			78h	78h	EFh	EFh	BFM 199, lower 8 bit
					F0h	F0h	BFM 199, higher 8 bit

5.2 BFM access to the Object Dictionary - Read FROM

Use the FROM instruction to read values from these locations in the Object Dictionary.

Table 5.2: CAN bus Object Dictionary - FROM Instruction Access

Index A6C0h float 32 bit object	Index A680h unsigned 32 bit object	Index A640h signed 32 bit object	Index A580h unsigned 16 bit object	Index A540h signed 16 bit object	Index A4C0h unsigned 8 bit object	Index A480h signed 8 bit object	BFM (FROM access)			
sub- index	sub- index	sub- index	sub- index	sub- index	sub- index	sub- index				
01h	01h	01h	01h	01h	01h	01h	BFM 0, lower 8 bit			
					02h	02h	BFM 0, higher 8 bit			
			02h	02h	02h	02h	02h	03h	03h	BFM 1, lower 8 bit
								04h	04h	BFM 1, higher 8 bit
02h	02h	02h	03h	03h	05h	05h	BFM 2, lower 8 bit			
					06h	06h	BFM 2, higher 8 bit			
			04h	04h	04h	04h	04h	07h	07h	BFM 3, lower 8 bit
								08h	08h	BFM 3, higher 8 bit
03h	03h	03h	05h	05h	09h	09h	BFM 4, lower 8 bit			
					0Ah	0Ah	BFM 4, higher 8 bit			
			06h	06h	06h	06h	06h	0Bh	0Bh	BFM 5, lower 8 bit
								0Ch	0Ch	BFM 5, higher 8 bit
.			
.			
.			
0Ah	0Ah	0Ah	13h	13h	25h	25h	BFM 18 lower 8 bit			
					26h	26h	BFM 18 higher 8 bit			
			14h	14h	14h	14h	14h	27h	27h	BFM 19, lower 8 bit
								28h	28h	BFM 19, higher 8 bit
0Bh	0Bh	0Bh	15h	15h	29h	29h	BFM 100, lower 8 bit			
					2Ah	2Ah	BFM 100, higher 8 bit			
			16h	16h	16h	16h	16h	2Bh	2Bh	BFM 101, lower 8 bit
								2Ch	2Ch	BFM 101, higher 8 bit
.			
.			
.			
3Ch	3Ch	3Ch	77h	77h	EDh	EDh	BFM 198, lower 8 bit			
					EEh	EEh	BFM 198, higher 8 bit			
			78h	78h	78h	78h	78h	EFh	EFh	BFM 199, lower 8 bit
								F0h	F0h	BFM 199, higher 8 bit

5.3 CANopen Object Dictionary Structure

5.3.1 The General Setup

The general setup for the CANopen Object Dictionary is shown in Table 6.3 below.

Table 5.3: General Object Dictionary Structure

Index (hex)	Object type
0000	Not Used
0001 - 001F	Static Data Types
0020 - 003F	Complex Data Types
0040 - 005F	Manufacturer Specific Data Types
0060 - 007F	Device Profile Specific Static Data Types
0080 - 009F	Device Profile Specific Complex Data Types
00A0 - 0FF0	Reserved
1000 - 1FFF	Communication Profile Area
2000 - 5FFF	Manufacturer Specific Profile Area
6000 - 9FF9	Standard Device Profile Area
A000 - FFFF	Reserved

5.3.2 The Detailed Object Dictionary Contents (According to DS-301*)

The detailed setup for the CANopen Object Dictionary for the CANopen node is shown below.

Table 5.4: Detailed Object Dictionary Structure

Index (hex)	Object type
1000	Device Type
1001	Error Register
1004	Number of PDOs supported
1005	COB-ID of SYNC message (producer/consumer can be selected)
1006	Communication Cycle Period (defines SYNC message timing)
1007	Synchronous Window Length (defines SYNC time window)
1008	Manufacturer Device Name
1009	Hardware Version
100A	Software Version
100B	Node ID
100C	Guard Time
100D	Life Time Factor
1010	Store Parameter to Flash
1011	Restore Parameter
1400 ~ 1BFF	PDO Parameter, PDO Mapping

6. The Command Interface

The Command Interface (CIF) is located in BFMs 1000~1066 and can be used to access the CANopen Object Dictionary to perform the following commands:

SDO Read Request - Read the value of an index/subindex of the Object Dictionary (local or network node).

SDO Write Request - Write a value to an index/subindex of the Object Dictionary (local or network node).

LAYER 2 message write Request - Write a layer 2 message to the CAN bus.

Local Receive PDO Refresh - Request a transmission of a local Rx-PDO to the network.

Define/Change the PDO Mapping/Binding of the Network

Setup the Guarding Parameter

Read the Guarding Status

Reset the Guarding Status Latch

Read the Emergency Message Buffer

Clear the Emergency Message Buffer

6.1 SDO Read Request

The SDO (Service Data Object) command can access all nodes on the CAN network via the Object Dictionary by using FROM/TO commands using the appropriate BFMs.

A PLC can access the connected FX2N-32CAN module by writing the actual module address (1~127) or by writing "0" in the FROM/TO command.

To initialize the SDO Read command, the value of the node address must be written to BFM 1001, the Object Dictionary Index to BFM 1002, and the Subindex to BFM 1003. Finally, the command code for SDO Read Access, "4", must be written to BFM1000.

If the access has been successful BFM1000 will display "5", BFM 1003 will contain the node address, index and subindex numbers for verification purposes. The length of the read data (in bytes) will be stored in BFM1004 and BFM1005~BFM1063 will contain up to 118 data bytes.

Byte order: 1st data byte = BFM1005 low byte, 2nd data byte = BFM1005 high byte, 3rd data byte = BFM1006 low byte, 4th data byte = BFM1006 high byte, etc.

6.2 SDO Write Request

The SDO (Service Data Object) command can access all nodes on the CAN network via the Object Dictionary by using FROM/TO commands.

A PLC can access the connected FX2N-32CAN module by writing the actual module address (1~127) or by writing "0" in the FROM/TO command.

To initialize the SDO Write command, the value of the node address must be written to BFM 1001, the Object Dictionary Index to BFM 1002, and the Subindex to BFM 1003. Finally, the command code for SDO Write Access, "2", must be written to BFM1000.

If the access has been successful BFM1000 will display "3", BFM 1003 will contain the node address, index and subindex numbers for verification purposes.

Table 6.1: BFM Structure for the SDO Read/Write Commands

BFM #	READ (FROM)	WRITE (TO)
BFM1000	Result (Read 0005, Write 0003) CIF BUSY (FFFF hex)	Command (Read 0004/ Write 0002)
BFM1001	Node Address	Node Address
BFM1002	Index	Index
BFM1003	Subindex	Subindex
BFM1004	Data Length	Data Length
BFM1005	Result Data	Command Parameter Data
BFM1006	Result Data	Command Parameter Data
BFM1007	Result Data	Command Parameter Data
BFM1008	Result Data	Command Parameter Data
BFM1009	Result Data	Command Parameter Data
BFM1010	Result Data	Command Parameter Data
:	:	:
:	:	:
:	:	:
BFM1062	Result Data	Command Parameter Data
BFM1063	Result Data	Command Parameter Data
BFM1064	Unused	Unused
BFM1065	Unused	Unused
BFM1066	Unused	Unused

6.3 Layer 2 Messages

Using this function, the PLC can send any Layer 2 messages to the CAN bus.

Incorrect use of this command can cause strange behavior in the CANopen network. Please take care to use this function only for special purposes.

Table 6.2: Layer 2 Message Commands

BFM#	READ (FROM)	WRITE (TO)
BFM1000	There are no Special Return Values but the "Queue not Available" error may occur under high busload conditions. CIF busy (FFFF hex)	Command (000C hex)
BFM1001		COB-ID (low word), *1
BFM1002		COB-ID (high word), *1
BFM1003		RTR (Remote Transmission Request), *2
BFM1004		DLC (Data Length Count), *3
BFM1005		Data byte 2, data byte 1, *4
BFM1006		Data byte 4, data byte 3, *4
BFM1007		Data byte 6, Data byte 5, *4
BFM1008		Data byte 8, Data byte 7, *4
BFM1009 : : : BFM1066	Unused	Unused

*1 - 11 bit Identifier (COB-ID) for transmission identification.

*2 - Set this BFM to "0" for normal transmission. If this BFM is set to "1", a request frame is sent. This request makes the producer of the associated CAN-ID specified in BFM 1001/1002 send the actual data.

*3 - The data length in bytes.

*4 - The data byte order is the same as the SDO Read and Write Requests.

6.3.1 The PDO Remote Transmission Request

This function can be used to refresh the local receive data buffer.

Basically, a CANopen node will not send its data unless a trigger-condition occurs (I/O change, SYNC signal, or manufacturer specific events). The data in the local receive data buffer may not be exactly the same as the data in the CANopen node that produces the data. This does not mean that the local data is wrong, it means that according to the configuration of the CANopen node producing the data, a transmission is/was not necessary. There may be no need to monitor an Hour meter on a minute by minute basis, for example, or there might be analog data that is triggered when it reaches a certain level.

With the PDO Remote Transmit Request, the data receiver can send a request to the data producer that the latest data be transmitted.

To refresh the receive data buffer, write the receive PDO number to BFM1001 and set BFM1000 to “8100” hex. The requested PDO must exist in the local Object Dictionary and has to be properly configured because all parameter data are taken from the local Object Dictionary.

The PDO number “0” will cause the request of all local configured Rx-PDOs.

If the result in BFM1000 becomes “8101” hex, the rtr frame has been successfully sent to the transmit queue. If the CIF was not able to access the queue, the result in BFM1000 will be “8FFF” hex. If the PDO specified by BFM1001 was not configured (COB ID 80000000 hex), the result in BFM 1000 will be “81FF” hex and BFM 1001 will display the PDO number.

Table 6.3: PDO Remote Transmission BFM Structure

BFM #	READ (FROM)	WRITE (TO)
BFM1000	Request successfully sent (8191 hex) No COB-ID found (81FF hex), *2 CIF BUSY (FFFF hex)	Command (8100 hex)
BFM1001	Rx-PDO number, *2	Local Rx-PDO number, *1
BFM1002 : BFM1066	Unused	Unused

*1 If the PDO rtr command is used with parameter “0”, the module will read the local object dictionary to get the first PDO Identifier (COB-ID) to request, afterwards the rtr frame is assembled and sent. Next, the second PDO Identifier is read from the local object dictionary and the process repeats. After all PDOs have been requested to the network (or skipped if the PDO was not configured), the result in BFM 1000 is set to “8101” hex.

The process to request all configured PDOs to the network may take some time, as long as the command is being executed the result BFM1000 will display CIF busy (FFFF hex). To abort a running remote transmission command, “FFFF” hex can be written to the command BFM 1000. When the result BFM 1000 does not display “CIF busy” anymore, the CIF is ready to receive new commands.

*2 If a single PDO number is requested to be refreshed and the CIF could not find a valid COB-ID in the object dictionary, the error message “no COB ID found for requested PDO” (81FF hex) will be displayed in BFM1000. The Rx-PDO number which caused the failure can be read from BFM1001.

6.4 Error Messages

If the BFM1000 receives a value of “000F” hex, an error has occurred during the execution of a command.

6.4.1 General Error Messages

Table 6.4: Error Messages when BFM1000 = 000F hex

BFM#	Short Description	SDO Error	Unknown Command Used	Queue was not Available	Command or Parameter Change While CIF was Busy	CIF Internal Error
BFM1000	Error	000F hex	000F hex	000F hex	000F hex	000F hex
BFM1001	Error Class	0003	0064 hex	8FFF hex	FFFF hex	00C8 hex
BFM1002	Additional Data, Error Class Dependent	Device ID				Content of Error Buffer
BFM1003		Low Word of Error Code, *3				Content of Error Buffer
BFM1004		High Word of Error Code, *4				Content of Error Buffer
BFM1005						Content of Error Buffer
BFM1006						Content of Error Buffer
BFM1007						Content of Error Buffer
BFM1008						Content of Error Buffer
:						:
:						:
:						:
BFM1064						Content of Error Buffer
BFM1065						Content of Error Buffer
BFM1066						Content of Error Buffer

*2 - Device ID which caused the error when it was accessed by SDO

*3 - Low word of error code (see DS-301, DS-405)

*4 - High word of error code (see DS-301, DS-405)

6.4.2 Local SDO Error Codes (BFM1001 = 3)

Table 6.5: Local Node Error Codes

SubIndex # x byte data	Local Error Description
0 x 50000000	Time out <u>or</u> Impossible to allocate identifier for SDO transmission <u>or</u> Protocol mismatch
0 x 60600000	Buffer too small for received SDO data (this error will occur during initialisation of the transmission)
0 x 08000020	Buffer too small for received SDO data (this failure will occur ONLY during transmission)
0 x 08000022	Different transmission for requested SDO already running

6.4.3 Remote SDO Error Codes (BFM1001 = 3)

Table 6.6: Remote Node Error Codes

SubIndex # x byte data	Local Error Description
0 x 05030000	Toggle bit not alternated
0 x 05040000	Time Out value reached
0 x 05040001	Client/Server command specifier no valid or unknown
0 x 06010000	Requested access type is not supported for this Object (attempting to Read a Write Only device)
0 x 06010000	Requested access type is not supported for this Object (attempting to Write to a Read Only device)
0 x 06020000	Requested Object does not exist in the Object Dictionary
0 x 06040000	The index is reserved for future use
0 x 06040041	The Object cannot be mapped to the PDO
0 x 06040042	Number and length of the Object to be mapped would exceed PDO length
0 x 06040043	General parameter incompatibility
0 x 06040047	General internal incompatibility in the device
0 x 06060000	Buffer too small for received SDO data (this error will occur during initialisation of the transmission) or Access failed because of a hardware error
0 x 06070010	Data type does not match, length of service parameter does not match
0 x 06070012	Data type of Write access and destination does not match (service parameter too long)
0 x 06070013	Data type of Write access and destination does not match (service parameter too short)
0 x 06090011	Requested Sub-Index does not exist
0 x 06090030	Requested Write access exceeds value range of this parameter

Table 6.6: Remote Node Error Codes

SubIndex # x byte data	Local Error Description
0 x 06090031	Value of the parameter to Write is too high
0 x 06090032	Value of the parameter to Write is too low
0 x 06090036	Maximum value is less than minimum value
0 x 08000020	Buffer too small for received SDO data (this failure will occur ONLY during transmission)
0 x 08000021	Data cannot be transferred or stored to the application because of local control
0 x 08000022	The data cannot be transmitted in the actual module status.
0 x yyyyyyyy	If the transfer is aborted by the communication partner, the corresponding abort code is displayed here. This can be an error code from a remote station which must be checked in the User's Manual of that station.

6.4.4 Unknown Command Used (BFM1001 = 100)

The command code sent from the PLC to BFM1000 is unknown.

6.4.5 Queue was not available (BFM1001 = 8FFFF hex)

At this time the access to the internal transmission queue was rejected (it is possible that the bus load was too high).

6.4.6 Command or Parameter Change while CIF was busy (BFM1001 = FFFF hex)

After the CIF has received a new command in the BFM1000 it will start to execute this command with the parameters given in BFM1001~BFM1006. After the command has been written TO BFM1000, the result (FROM) BFM1000 will display "CIF busy" (FFFF hex). [There are two BFM1000s, one for the TO command and one for the FROM command.] After the command written to BFM1000 has been processed, the result (FROM) BFM1000 will be set to the corresponding success/failure code and will not contain the value FFFF hex.

If any BFM from 1000 ~ 1066 is accessed by a TO command while the CIF is busy, the data is not written the BFM area and the "Command or parameter change while CIF was busy" Error is displayed in the result BFM. This error status must be acknowledged/reset by a special command to make the CIF available again (see section 9.4.7).

6.4.7 The Clear/Reset "CIF was busy" Error

To Reset the CIF after a "Command or Parameter Change while CIF was busy" Error, FFFF hex must be written using the TO command to BFM1000. The CIF is available again if the BFM1000 displays 0000 hex.

Note: If the FX2n-32CAN is in From/To watchdog error, the command execution is shifted as long as the FROM/TO error is not reset.

6.4.8 CIF Internal Error (BFM1001 = 200 hex)

This error code was implemented to handle possible errors which are not covered by the normal error detection. If an error occurs which does not have a corresponding error code, a classification value will be displayed in BFM1002 and the internal error data buffer is copied to BFM1003~1066.

If this error occurs, please contact your service representative.

7. The Mapping Modes

In order to exchange data over the CANopen but the data channels between nodes must be defined or “mapped”. The FX2N-32CAN module has been pre-configured to support three defined mapping modes or can be configured completely to suit the user needs.

A network configuration tool is a powerful device for setting the parameter data for any manufacturers node (including the FX2N-32CAN) and defining the data mapping connection set. It is recommended to use a network configuration tool for large networks due to the convenience, flexibility, and ease of use that the tools provide.

To build up a small network or for testing purposes, the module Command InterFace (CIF, see Chapter 9) supports three PDO mapping/binding commands designed for and supported by the FX2N-32CAN module. By using these predefined Mapping configurations, the CAN object ID (COB-ID) number for data exchange for each node is clearly defined. For example an Rx-PDO (receive process data object) can be connected to a Tx-PDO (transmit process data object) of another node. These data will always be transmitted with the same COB-ID and every node can distinguish relevant data by checking the COB-ID.

Note: It is strongly recommended to execute the Mapping Commands only in the pre-operational or stopped mode of the local and all related CANopen nodes.

Vocabulary Terms

Rx-PDO - Receive Process Data Objects are data read from other nodes via the CAN bus.

Tx-PDO - Transmit Process Data Objects are the data sent to other nodes via the CAN bus.

CIF - The Command InterFace is the FX2N-32CAN tool used to perform actions such as to set parameters, execute commands, establish communication connections, access the CANopen Object Dictionary, and read error messages. It is located in BFM 1000~1066.

COB-ID - The CAN Object ID number is a unique identifying number to distinguish between different messages on the CANBus (e.g. PDO, SDO,NMT,SYNC, EMCY messages)

BFM - The Buffer Memory is the data storage memory location.

Mapping Mode 0 - Base Configuration where 4 Rx-PDOs and 4 Tx-PDOs are given BFM assignments for each FX2N-32CAN node according to the pre-defined connection set of CANopen.

Mapping Mode A - Mitsubishi Electric defined configuration for the FX2N-32CAN module that defines the relationship between up to eight FX2N-32CAN nodes, the node BFMs, and the Rx-PDOs and Tx-PDOs. This mode is very convenient if every node is an FX2N-32CAN module.

Mapping Mode B - Configuration mode that allows specific Rx-PDOs and Tx-PDOs to be matched on a node by node basis.

For more information on the CANopen specifications please see the Can-in-Automation website at www.can-cia.de.

7.1 Factory Default Mapping/Mode 0 Mapping

The Factory Default Mapping conforms to CANopen specification DS-301 and contains only the first 2 Tx-PDOs and the first two Rx-PDOs. Please refer to the Tables in section 10.4 that give, respectively, the relationships between Tx-PDO number/COB-IDs/BFM# and the Rx-PDO/COB-IDs/BFM#.

By executing the Mode 0 mapping command shown below the number of automatically assigned Tx-PDOs becomes four instead of two. Four Rx-PDOs are also mapped automatically.

Table 7.1: Mode 0 Mapping Command

BFM#	READ (FROM)	WRITE (TO)
BFM1000	Mapping successfully established (8901)	Command (8900 hex)
BFM1001	Unused	Unused
:	Unused	Unused
BFM1066	Unused	Unused

The BFM 0-15 are distributed to Rx-PDOs 1-4 and Tx-PDOs 1-4 as shown in section 5.4. This setting is useful for a network that features many different types of node or as a base for a network mapping configured with the Mode B mapping command.

The PDOs from 5-30 (BFM16~19 and BFM100~199) are disabled in the default settings but further mapping of BFM16~19 and BFM100~199 can be accomplished using the Mode B mapping technique.

7.2 Mode A Mapping

Setting up a CANopen network of only FX2N-32CAN nodes can be accomplished by simply using the Mode A Mapping configuration. Other types of CANopen modules can be added to the Network but additional user inputs are necessary.

Table 7.2: Mode A Mapping Command

BFM#	READ (FROM)	WRITE (TO)
BFM1000	Mapping successfully established (8201 hex). Local node number MUST be in the range 1 - 8 (82FF hex)	Command (8200 hex)
BFM1001	Unused	Unused
:	Unused	Unused
BFM1066	Unused	Unused

To establish communication between a FX2N-32CAN node and up to 7 other FX2N-32CAN nodes it is only necessary to write the “set Mode A Mapping” command (8200 hex) to all the FX2N-32CAN modules via the local PLC. One of the nodes must be configured as the network manager. The network manager can be defined in the Network Configuration tool or by writing to the Object Dictionary using the CIF SDO write command.

When all the stations have executed the Mode A Mapping command, it is possible to exchange 16 data words with every other FX2N-32CAN module*. Due to the data size, the number of nodes in this mapping Mode is limited to 8 stations. *If the node number is outside the range 1-8, BFM1000 will display the “node number mismatch” error message (82FF hex).*

*Note: Nodes 1 - 7 can exchange 16 words of data with every other node but station number 8 can send just 8 words of data to the other 7 stations. Node 8 can read the 16 words of data from all the other stations.

A closer look at the mapping shows that the Tx-PDO is dependent upon the node ID but the mapping for the Rx-PDO is fixed to the default Tx-PDO COB-ID of the stations 1-8. The advantage is that the data location of the other nodes are the same for all FX2N-32CAN modules [eg. station #3 is always BFM112-127 (FROM)].

To include other types of CANopen nodes in the Mode A network, it is necessary to change the Rx-PDO and communication parameters of these stations. This can be done by the Mode B mapping commands, the SDO write access Command, or by a standard configuration tool.

Note: For Mode A Mapping the node number of the local FX2N-32CAN node must be in the range 1-8. If the node number is different, the result BFM1000 will display the "node number mismatch" (82FF hex) error message.

7.3 Mode B Mapping

With Mode B Mapping, it is possible to build up a binding (a connection between two node addresses) between all nodes connected to the FX2N-32CAN module. Also, the binding of any CANopen node with any other CANopen node is supported. The Mode B mapping is limited to the binding of the PDOs which are already configured in the remote stations (no change of the mapping between CANopen data and the remote node's hardware) which will be suitable for most cases.

7.3.1 Prepare the PDO Mapping Table

The Mode B mapping command will modify or add to the current PDO mapping, therefore it is important to have a clearly defined mapping base before executing any Mode B commands. Executing the Mode B Mapping commands before creating a PDO mapping base may create errors in the data transmission or module operation.

The PDO mapping base can be the "Mode 0" mapping or the "Mode A" mapping explained in previous sections to prepare the default Rx-PDO and Tx-PDO formats as shown in section 10.4. Another method to create (or reset) a Mapping base is to initialize the Mode B Mapping with a special instruction at the beginning of the Mode B Mapping Command.

The purpose of the Mode B Mapping Commands is to bind a Tx-PDO from one CANopen node to a Rx-PDO of another node. This allows certain Buffer Memory information to be transferred/read in designated nodes around the CANopen network.

The Source parameter specifies the Node number and the specific Tx-PDO. The Destination parameter specifies the Node number and the specific Rx-PDO that can read the data. The command consists of four hexadecimal numbers, the two higher byte numbers specify the node number and the two lower numbers specify the appropriate PDO number.

If it is necessary to change the remote node hardware mapping, this can be done by the SDO write access command or by a standard configuration tool.

The configuration with the Mode B mapping is controlled by a parameter set which is displayed in the table below.

Table 7.3: Mode B Mapping Command

BFM#	READ (FROM)	WRITE (TO)
BFM1000	Binding done without errors - 8301 H. Binding error occurs - Hex 83FF H. CIF BUSY (FFFFh)	Command (8300 hex)
BFM1001	Diagnosis Data: 0000 hex = no error All other Values: The Corresponding parameter cause an error (BFM 1000 will be 83FF hex)	Source 1 [*1]
BFM1002		Destination 1 [*2]
BFM1003		Source 2 [*1]
BFM1004		Destination 2 [*2]
BFM1005		Source 3 [*1]
BFM1006		Destination 3 [*2]
BFM1007		Source 4 [*1]
BFM1008		Destination 4 [*2]
BFM1009		Source 5 [*1]
BFM1010		Destination 5 [*2]
BFM1063		Source 32 [*1]
BFM1064		Destination 32 [*2]
BFM1065		Source 33 [*1]
BFM1066		Destination 33 [*2]

There is a special parameter to set up the PDO mapping table. If Source1 (BFM1001) and Destination1 (BFM1002) are set to 0000 hex, the PDO mapping will be reset to the state shown in section 10.4. The prepare parameter must be set in the first Source/Destination parameter set, if it is used in Source2/Destination2 ~ Source33/Destination33 it will be ignored and will generate an error message. If it is necessary to execute the mode B mapping more than one time to bind all PDOs, the preparation command must not be set in the second or following parameter sets. When the preparation command is used, all previous bindings will be reset.

Note: The parameter set must be terminated by the “end of binding Table” parameter. This is accomplished by setting the Source parameter that follows the final binding parameter to FFFF hex.

With one execution of the Mode B mapping command up to 33 binding connections between CANopen stations can be made. To establish more data connections, the command can be repeated as often as necessary.

The mode B mapping commands can be used in the same manner if Mode 0 or Mode A is used as a base configuration.

7.3.2 The Source Command

The task of the mapping command is to connect a data producer and a data consumer PDO to the same message identifier. The Source Parameter specifies the producer to the data telegram to bind.

The high byte of this parameter is the node ID number. The node ID range is 1~127. The local FX2N-32CAN module can be specified by the actual node number or by using a "0".

The low byte specifies the PDO number. The FX2N-32CAN module will start a read access to the object dictionary of the source node to read the COB-ID. This COB-ID is written in the next step to the Destination node's PDO mapping table.

Ex. Source = 1009 hex. The node number is the high byte or node 10. The low byte designates Tx-PDO 09. This information will be bound to the node/Rx-PDO in the Destination BFM that directly follows the Source BFM.

Note: An error will be generated if the Destination BFM is not configured.

7.3.3 The Destination Parameter

This parameter defines the Destination for the corresponding Source parameter data. The high byte of the BFM signifies the node number where the data is received and the low byte signifies the Rx-PDO which is the final destination.

Ex. Destination = 0203 hex. The Source data will be bound to PDO #3 of Node 2.

The Destination node COB-ID is checked before the Source data is written to the mapping table.

Note: An error message will be received if the Destination PDO was not written to the destination PDO.

Note: The mode B mapping command cannot be used to change the mapping of the PDOs and/or the Hardware of the Remote modules. This type of network setup can be accomplished by the SDO write access command or by a standard configuration tool.

7.3.4 Assign Additional COB-IDs to the Local Node

By default every CANopen node can use four COB-IDs to transmit its data to other CANopen stations. All COB-IDs for Data transmission are by default reserved for the nodes 1~127. If it is necessary to transmit more than 4 PDOs (more than 16 words) from one node, this node must occupy COB-IDs of other (unused) stations. It is recommended to use the identifier of higher number stations for this purpose (127, 126, 125, etc). The lower the used COB-ID is, the higher is the priority of the messages. According to this, for highly important data it should be avoided to assign the COB-ID of the Tx-PDO4/node 127 because all other Tx-PDO COB-IDs have a higher priority for transmission on the CANopen bus.

The Source parameter high byte defines the node which is by default the "owner" of the COB-ID to occupy, the low byte defines the PDO number (Tx COB-ID = 0180 hex + node ID for Tx-PDO1/ 0280 hex + node ID for Tx-PDO2/ 0380 + node ID for Tx-PDO3/ 0480 hex + node ID for Tx-PDO4).

To assign a COB-ID by the local station, the high byte number must be set to 80 hex.

The low byte tells the PDO number in the local station which shall use the occupied COB-ID.

Ex. Source = 7F01 hex, Destination = 8005 hex

The local FX2N-32CAN module will transfer the BFM's mapped to Tx-PDO 5 with the COB-ID of 1FF hex (by default this would be PDO 1 of node 127 = 180 + 127).

Note: The local Tx-PDO numbers 1-4 are using the COB-IDs 180 hex + local node ID to 480 hex + local node ID which are the standard COB-IDs. An attempt to assign a COB-ID to the first four PDOs will cause an error.

7.3.5 The End of the Parameter Table

If the last parameter is not located in BFM1065/1066, the parameter set must be terminated with Source = FFFF hex.

7.4 PDO Mapping Table Overviews

7.4.1 Tx-PDO Mapping Table

Table 7.4: Tx-PDO Mapping Table

	Default Factory/ Mode 0 Mapping*	Mode A Mapping	Mode B Mapping (after PDO mapping is prepared)	Assigned BFM
	COB ID			Mapped BFMs (access style)
Tx-PDO 1		0180 hex + node ID		BFM#3, BFM#2, BFM#1, BFM#0
Tx-PDO 2		0280 hex + node ID		BFM#7, BFM#6, BFM#5, BFM#4
Tx-PDO 3		0380 hex + node ID		BFM#11, BFM#10, BFM#9, BFM#8
Tx-PDO 4		0480 hex + node ID		BFM#15, BFM#14, BFM#13, BFM#12
Tx-PDO 5	Disabled (COB-ID set to 80000000 hex). These PDOs can be activated by mode B mapping commands.		Disabled (COB-ID set to 80000000 hex). Can be defined by mode B mapping command parameter	BFM#19, BFM#18, BFM#17, BFM#16
Tx-PDO 6				BFM#103, BFM#102, BFM#101, BFM#100 (TO)
Tx-PDO 7				BFM#107, BFM#106, BFM#105, BFM#104 (TO)
Tx-PDO 8				BFM#111, BFM#110, BFM#109, BFM#108 (TO)
Tx-PDO 9				BFM#115 ... BFM#112 (TO)
Tx-PDO 10				BFM#119 ... BFM#116 (TO)
Tx-PDO 11				BFM#123 ... BFM#120 (TO)
Tx-PDO 12				BFM#127 ... BFM#124 (TO)
Tx-PDO 13				BFM#131 ... BFM#128 (TO)
Tx-PDO 14				Disabled (COB-ID set to 80000000 hex). These PDOs can be activated by mode B mapping commands.
Tx-PDO 15	BFM#139 ... BFM#136 (TO)			
Tx-PDO 16	BFM#143 ... BFM#140 (TO)			
Tx-PDO 17	BFM#147 ... BFM#144 (TO)			
Tx-PDO 18	BFM#151 ... BFM#148 (TO)			
Tx-PDO 19	BFM#155 ... BFM#152 (TO)			
Tx-PDO 20	BFM#159 ... BFM#156 (TO)			
Tx-PDO 21	BFM#163 ... BFM#160 (TO)			
Tx-PDO 22	BFM#167 ... BFM#164 (TO)			
Tx-PDO 23	BFM#171 ... BFM#168 (TO)			
Tx-PDO 24	BFM#175 ... BFM#172 (TO)			
Tx-PDO 25	BFM#179 ... BFM#176 (TO)			
Tx-PDO 26	BFM#183 ... BFM#180 (TO)			
Tx-PDO 27	BFM#187 ... BFM#184 (TO)			
Tx-PDO 28	BFM#191 ... BFM#188 (TO)			
Tx-PDO 29	BFM#195 ... BFM#192 (TO)			
Tx-PDO 30	BFM#199 ... BFM#196 (TO)			

7.4.2 Rx-PDO Mapping Table

Table 7.5: Rx-PDO Mapping Table

Rx-PDO#	Default Factory/ Mode 0 Mapping*	Mode A Mapping	Mode B Mapping (after PDO Mapping is prepared)	Assigned BFM	
	COB ID			Mapped BFMs (access style)	
Rx-PDO 1	0200 hex + node ID	181 hex	Node 1 Data	Disabled (COB-ID set to 80000000 hex). Can be defined by mode B mapping command parameter.	BFM#3, BFM#2, BFM#1, BFM#0 (FROM)
Rx-PDO 2	0300 hex + node ID	281 hex			BFM#7, BFM#6, BFM#5, BFM#4 (FROM)
Rx-PDO 3	0400 hex + node ID	381 hex			BFM#11, BFM#10, BFM#9, BFM#8 (FROM)
Rx-PDO 4	0500 hex + node ID	481 hex			BFM#15, BFM#14, BFM#13, BFM#12 (FROM)
Rx-PDO 5	Disabled (COB-ID set to 80000000 hex). These PDOs can be activated by Mode B mapping commands.	182	Node 2	Disabled (COB-ID set to 80000000 hex). Can be defined by mode B mapping command parameter.	BFM#19, BFM#18, BFM#17, BFM#16 (FROM)
Rx-PDO 6		282			BFM#103, BFM#102, BFM#101, BFM#100 (FROM)
Rx-PDO 7		382			BFM#107, BFM#106, BFM#105, BFM#104 (FROM))
Rx-PDO 8		482			BFM#111, BFM#110, BFM#109, BFM#108 (FROM)
Rx-PDO 9		183	Node 3 data		BFM#115, BFM#114, BFM#113, BFM#112 (FROM)
Rx-PDO 10		283			BFM#119 ... BFM#116 (FROM)
Rx-PDO 11		383			BFM#123 ... BFM#120 (FROM)
Rx-PDO 12		483			BFM#127 ... BFM#124 (FROM)
Rx-PDO 13	Disabled (COB-ID set to 80000000 hex). These PDOs can be activated by Mode B mapping commands.	184	Node 4 data	Disabled (COB-ID set to 80000000 hex). Can be defined by mode B mapping command parameter.	BFM#131 ... BFM#128 (FROM)
Rx-PDO 14		284			BFM#135 ... BFM#132 (FROM)
Rx-PDO 15		384			BFM#139 ... BFM#136 (FROM)
Rx-PDO 16		484			BFM#143 ... BFM#140 (FROM)
Rx-PDO 17		185	Node 5 data		BFM#147 ... BFM#144 (FROM)
Rx-PDO 18		285			BFM#151 ... BFM#148 (FROM)
Rx-PDO 19		385			BFM#155 ... BFM#152 (FROM)
Rx-PDO 20		485			BFM#159 ... BFM#156 (FROM)
Rx-PDO 21		186	Node 6 data		BFM#163 ... BFM#160 (FROM)
Rx-PDO 22		286			BFM#167 ... BFM#164 (FROM)
Rx-PDO 23		386			BFM#171 ... BFM#168 (FROM)
Rx-PDO 24		486			BFM#175 ... BFM#172 (FROM)
Rx-PDO 25		187	Node 7 data		BFM#179 ... BFM#176 (FROM)
Rx-PDO 26		287			BFM#183 ... BFM#180 (FROM)
Rx-PDO 27		387			BFM#187 ... BFM#184 (FROM)
Rx-PDO 28		487			BFM#191 ... BFM#188 (FROM)
Rx-PDO 29	188	Node 8 data	BFM#195 ... BFM#192 (FROM)		
Rx-PDO 30	288		BFM#199 ... BFM#196 (FROM)		

* The Factory Default Mapping contains only the first two Rx-PDOs and the first two Tx-PDOs as defined in DS-301. Mode 0 mapping sets the first four Rx-PDOs and Tx-PDOs as shown in the Tables.

7.4.3 Mode B Mapping Errors

If the CIF was not able to execute the “mode B Mapping” command with the given parameter set, it will return 83FF hex in BFM1000. BFM1001~1066 will show which parameter caused the error(s).

Ex. If parameter Source5 (BFM1009 TO) caused an error, the value of BFM1009 (FROM) will be different from 0.

7.4.4 Source Parameter Errors

There are four different states which can be displayed in BFM1001~1066 (nn = node ID, mm = PDO no.)

Table 7.6: Source Parameter Errors

Error Number	Description
FFFF hex	Node ID higher than 127 or PDO number 0
nn00 hex	No response from node nn (time out)
00mm hex	COB-ID is 80000000 hex (PDO disabled)
nnmm hex	Node nn rejected access to PDO mm mapping parameter (PDO number not supported)

7.4.5 Destination Parameter Errors

There are four different states which can be displayed in BFM1001 to BFM1066 (nn = node number, mm = PDO number).

Table 7.7: Destination Parameter Errors

Error Number	Description
FFFF hex	Node ID higher than 127, PDO number 0, or the Parameter may have been skipped if a Source error occurred.
nn00 hex	No response from node nn (time out)
00mm hex	Previous COB-ID of destination was 80000000 hex (PDO was disabled. Binding was accomplished but there might be an error in the hardware mapping for the destination node. *1
nnmm hex	Node nn rejected access to PDO mm mapping parameter (PDO number not supported)

*1 Please take care with this error message. If the destination PDO was disabled, it is not sure if there is some hardware mapping inside the destination node for this PDO. This node might receive the data but it is not transferred to any I/O or data register.

When the Destination node is an FX2N-32CAN the PDO data will be mapped to a BFM (if the hardware mapping was not changed previously). In the case of the FX2N-32CAN the error can be judged as a warning which can be completely avoided if the mapping is done by the remote FX2N-32CAN node itself.

Another possibility is to set the remote FX2N-32CAN to Mode A mapping. In this case all Rx-PDO COB-IDs are different from 80000000 hex, the disadvantage is that if all Rx-PDOs are mapped, they will also be received. This is not really a problem but the FX2N-32CAN cycle time will be a little bit higher and it may be confusing if unused BFMs are also change their data values.

Note: If the local FX2N-32CAN is the destination, this error is disabled.

7.4.6 Other Errors

If the prepare mode B mapping parameter (0000 hex) is used (nn = node ID, mm = PDO no.):

Table 7.8: Prepare Parameter Setting

Error Number	Description
FFFF hex	Parameter can be used only as Source1/Destination1 (BFM1001/BFM1002)

If the occupy parameter is not set properly:

Table 7.9: Occupy Parameter Error

Error Number	Description
nnmm hex	Source node nn must be in the range 1 to 127 and PDO number mm must be 1~4 (for Source Parameter), 5~127 (Destination Parameter).

8. Node Guarding

Nodes can be set to Guarding-Master or Guarding-Slave status by writing values to Index 1F81 using the Command Interface (CIF). The parameters for the guarding are included in the information that can be written to the CAN bus. Please see Table 8.1 for details.

8.1 CIF/BFM Structure for Slave Guarding Assignment

Table 8.1: CIF Command for Slave Guarding Assignment

BFM#	READ (From)	WRITE (TO)
BFM 1000	Slaves have been Assigned - 8401 hex Parameter Error - 84FF hex CIF Busy - FFFF hex	Command - 8400 hex
BFM 1001	Diagnosis Data: 0000 hex = no error	Slave # to be Guarded (See Section 7.2.1)
BFM 1002		Requested Services (See Section 7.2.2)
BFM 1003		Guard Time (See Section 7.2.3)
BFM 1004		Retry Factor (See Section 7.2.4)
BFM 1005		Slave # to be Guarded
BFM 1006		Requested Services
BFM 1007		Guard Time
BFM 1008		Retry Factor
:		:
:		:
BFM 1061	All other Values: the corresponding parameter caused an error.	Slave # to be Guarded
BFM 1062		Requested Services
BFM 1063		Guard Time
BFM 1064		Retry Factor
BFM 1065		Unused
BFM 1066		Unused

8.2 Node Guarding Parameter Settings

The following parameters define the Slave Node Guarding.

8.2.1 Slave Number

This parameter specifies the slave number which shall be guarded by the local FX2N-32CAN node. This is only valid if the Network Manager function is activated for the local station.

The CANopen Object Dictionary uses Index value 1F81 hex for Node Guarding values. The FX2N-32CAN module is set to write to this index automatically when using the TO commands as outlined in Table 8.1.

8.2.2 Services Requested

This parameter specifies the services requested below.

Table 8.2: Service Request Table

Bit Number	Bit = 0	Bit = 1
Bit 0	Node is not a slave	Node is a slave. After Configuration, the node will be set to operational.
Bit 2	On guard error or boot up detection DO NOT automatically configure and start the slave.	On guard error or boot up detection automatically configure the slave via Configuration Manager and afterward set the slave to operational.
Other bits	Unused	

8.2.3 Guard Time

The station which is configured to guard one or more nodes will send a Guard request every “n x 1ms” to the network. If no response is received from the slave station, the request is repeated after the next “n x 1ms” has elapsed until the specified number of retries has been submitted. If no response is received, a Guarding error will occur.

8.2.4 Number of Retries

This parameter defines the number of retries for the Guard Request to poll the node before an error is recorded.

8.2.5 End of Parameter Table

After setting the parameters one or more nodes to be guarded, a setting must be given to signal the end of the parameter write. This is accomplished by writing FFFF hex in the “Slave Number to be guarded” following the last node configuration setting. If the final setting is located in BFM1061 - BFM1064, writing FFFF hex is not required.

8.2.6 Parameter Errors

If the node number to be guarded exceeds the range 1~127, the corresponding BFM will display the value which caused the problem.

The FX2N-32CAN module may write a value of FFFF hex to the “Requested Services” parameter of a node that has a parameter configuration error.

The FX2N-32CAN module may write a value of FFFF hex to the “Guard Time” parameter of a node that has a parameter configuration error.

If the “Retry Factor” parameter exceeds 255, an error value will be displayed in the corresponding BFM. The FX2N-32CAN module may write a value of FFFF hex to the “Retry Factor” parameter of a node that has a parameter configuration error.

If the node number, requested services, retry factor and guarding time is just copied to the corresponding result BFMs (no parameter skipped FFFF hex), the remote node does not support Index 100C/100D hex (guarding time/retry factor). In this case, the remote node cannot detect a missing guarding request of the network manager.

8.2.7 Read Guarding Status

To Read the Guarding Status of the CANopen nodes guarded by the local station, the CIF supports a special read command. With a parameter in BFM1001 you can choose if the state of all the nodes or only single node shall be read.

Table 8.3: Read Guarding Status Settings

BFM#	READ (From)		WRITE (TO)
BFM 1000	Single node status displayed (8501 h) Next node with error displayed (8502 h) CIF BUSY (FFFF h)	All nodes status displayed (8503 hex) CIF BUSY (FFFF hex)	Command 8500 hex
BFM 1001	Node ID Status *2	Node 2 status *2	Node 1 status *2
BFM 1002	Unused	Node 4 status *2	Node 3 status *2
BFM 1003		Node 6 status *2	Node 5 status *2
BFM 1004		Node 8 status *2	Node 7 status *2
:			
:			
BFM 1063		Node 126 status, *2	Node 125 status, *2
BFM 1064		unused	Node 127 status, *2
BFM 1065			
BFM 1066		unused	

*1 The parameter given in BFM1001 will influence the display style of the Guarding status. If a node number (1~127) is written to the BFM1001, BFM1000 will display "Single node status displayed" (8501 hex). BFM1001 will show the node ID for verification purposes and BFM1002 will contain the guarding status flags.

The parameter value 128-255 written to BFM1001 will make the "read Guarding status" command display the next node number that is in some guarding error state. Another execution of the "read Guarding status" command with the parameter value 128-255 will display the next node with guarding problems, so it is possible to "jump" through all nodes with Guarding errors. BFM1000 will display a value of 8502 hex if the "Display next node with guarding error" parameter has been used, BFM1001 will show the node ID for verification purpose and BFM1002 will contain the guarding status flags. If currently no node is in guarding error state, the BFMs 1001 and 1002 will display 0.

If BFM 1001 is set to "0", the status of all 127 nodes is displayed in BFM1001 to BFM1064 as shown in the table above and BFM1000 will display 8503 hex in this case.

The high byte of the parameter in BFM1001 is ignored!

*2 Node Guarding Status Flags

Bit 0 - Guarding is Activated

Bit 1 - Reserved

Bit 2 - One response is Missed

Bit 3 - No response and Lifetime Elapsed

Bit 4 - Toggle Error

Bit 5 - State changed (bus state of the node changed operational/pre-operational, etc.)

Bit 6 - Guarding failed for the local node (guarding request from the network manager was not received in the expected time).

Bit 7 - Reserved

8.2.8 Reset Guarding Status Latch

To reset the local guarding error latch the CIF supports the “reset Guarding status latch” command (8600 hex). A parameter given in BFM1001 decides if the guarding status of a special node or the status latch of all nodes will be reset. If BFM1001 is set to a value from 1 - 127, the corresponding node status latch is reset (the guarding error flags are set to “0”). A value of 0 or 128-255 in BFM1001 will cause the CIF to reset the complete local guarding error latch for all nodes.

Table 8.4: Reset Guarding Status Latch

BFM#	READ (FROM)	WRITE (TO)
BFM1000	Status latch was reset (8601 hex) CIF BUSY (FFFF hex)	Command 8600 hex
BFM1001	Unused	Node number (1 - 127) Reset complete latch (0, 128-255)
BFM1002		Unused
⋮ ⋮ BFM1066		

9. Emergency Messages

9.1 Read Emergency Message Buffers

The FX2N-32CAN will store the Emergency messages which are received from the bus to an internal buffer. This buffer can store up to 22 emergency messages and is separated in an 11 message stack buffer and an 11 message ring buffer. The stack buffer will store the first 11 emergency messages received after PWO or after the Emergency message buffer was cleared the last time. The ring buffer will store the next eleven Emergency messages, all further received Emergency telegrams will overwrite the oldest message in the ring buffer. The stack buffer will not be overwritten.

Table 9.1: Read EMERGENCY Message Buffer

BFM#	READ (FROM)	WRITE (TO)
BFM 1000	Stack buffer displayed (8701 hex) Ring buffer displayed (8702 hex) Single message displayed (8703 hex) CIF BUSY (FFFF hex)	Command - 8700 hex
BFM 1001	Node ID, *6	Read stack buffer (0), *1 Read ring buffer (1), *2 Read next unread buffer entry (2), *3 Read stack buffer & clear buffer (10 hex), *4 Read ring buffer & clear buffer (11 hex), *5
BFM 1002	Message Counter, *7	Unused
BFM 1003	EMERGENCY data, *8	
BFM 1004	EMERGENCY data, *8	
BFM 1005	EMERGENCY data, *8	
BFM 1006	EMERGENCY data, *8	
BFM 1007	Node ID, *6	Unused if single message is displayed
BFM 1008	Message Counter, *7	
BFM 1009	EMERGENCY data, *8	
BFM 1010	EMERGENCY data, *8	
BFM 1011	EMERGENCY data, *8	
BFM 1012	EMERGENCY data, *8	
	⋮	
BFM 1055	Node ID, *6	
BFM 1056	Message Counter, *7	
BFM 1057	EMERGENCY data, *8	
BFM 1058	EMERGENCY data, *8	
BFM 1059	EMERGENCY data, *8	
BFM 1060	EMERGENCY data, *8	
BFM 1061	Node ID, *6	
BFM 1062	Message Counter, *7	
BFM 1063	EMERGENCY data, *8	
BFM 1064	EMERGENCY data, *8	
BFM 1065	EMERGENCY data, *8	
BFM 1066	EMERGENCY data, *8	

*1 - If the parameter 0 is set in BFM1001, the “read Emergency buffer” command will display the complete stack buffer in the BFM1001 to BFM1066. The stack buffer always contains the first eleven emergency messages which have been received since the PWO or since the emergency buffer has been cleared the last time. If the stack buffer is displayed the BFM1000 will contain 8701 hex.

*2 - The parameter value 1 will cause the display of the whole content of the ring buffer. The oldest message will be displayed in BFM1001 to BFM1066, the later messages in the higher BFM. BFM1000 will display 8702 hex.

*3 - If the “read Emergency buffer” command is executed with the “read next unread buffer entry”, the CIF will display the next unread emergency message in BFM1001 to BFM1066. BFM1000 will display 8703 hex.

With every execution of the “read next unread buffer entry” command with this parameter, the CIF will show the next unread emergency message. After all unread messages have been processed, the following executions will show “0” in BFM1001 to BFM1066 unless a new emergency message is received.

*4 - Basically this parameter will cause the same behavior as the “read stack buffer” parameter but after the read access is finished, the internal emergency buffer is cleared (both stack and ring buffers!!). The next received emergency message will be stored in the first cell of the stack buffer.

*5 - Basically, this parameter will cause the same behavior as the “read ring buffer” parameter but after the read access is finished, the internal emergency buffer is cleared (both stack and ring buffers!!). The next received emergency message will be stored in the first cell of the stack buffer.

*6 - The ID number of the node which sent the emergency message to the network is displayed.

*7 - The message counter shows a value from 1 to 255. This figure is a kind of running counter which is increased with every incoming emergency message until a value of 255 is reached. The counter will stay at this value as long as the buffer is not cleared and the module stays powered On.

*8 - The next four BFMs contain the data of the emergency telegram. The first emergency data byte is located in the low byte of the first BFM, the second data byte in the high byte of the first BFM.

9.2 Send an Emergency Message

This command can be used to send an emergency message by the PLC to the CANopen network.

BFM#	READ (FROM)	WRITE (TO)
BFM 1000	No special return values, but the "Queue was not available" error may occur under high busload conditions. Also, CIF BUSY (FFFF hex)	Command - 000A hex
BFM 1001		Emergency Data byte 2 and 1, *1
BFM 1002		Emergency Data byte 4 and 3, *1
BFM 1003		Emergency Data byte 6 and 5, *1
BFM 1004		Emergency Data byte 8 and 7, *1

*1 - Emergency data defined in DS301 revision 3.0.

Write first emergency data byte to low byte of BFM1001, second emergency data byte to high byte of BFM1001, third emergency data byte to low byte of BFM1002, and so on.

Unused emergency data bytes HAVE TO BE filled with 00 hex.

MEMO

Under no circumstances will Mitsubishi Electric be liable or responsible for any consequential damage that may arise as a result of the installation, use and/or programming of the products associated with this manual.

All examples and diagrams shown in this manual are intended as an aid to understanding the text, not to guarantee operation. Mitsubishi Electric will accept no responsibility for actual use of the product based on these illustrative examples.

Owing to the very great variety of possible applications, users must satisfy themselves as to the suitability of each specific application.

HEADQUARTERS

MITSUBISHI ELECTRIC EUROPE B.V. **EUROPE**
 German Branch
 Gothaer Straße 8
D-40880 Ratingen
 Phone: +49 (0)2102 / 486-0
 Fax: +49 (0)2102 / 486-1120

MITSUBISHI ELECTRIC EUROPE B.V. **CZECH REPUBLIC**
 Czech Branch
 Avenir Business Park, Radlická 714/113a
CZ-158 00 Praha 5
 Phone: +420 - 251 551 470
 Fax: +420 - 251-551-471

MITSUBISHI ELECTRIC EUROPE B.V. **FRANCE**
 French Branch
 25, Boulevard des Bouvets
F-92741 Nanterre Cedex
 Phone: +33 (0)1 / 55 68 55 68
 Fax: +33 (0)1 / 55 68 57 57

MITSUBISHI ELECTRIC EUROPE B.V. **IRELAND**
 Irish Branch
 Westgate Business Park, Ballymount
IRL-Dublin 24
 Phone: +353 (0)1 4198800
 Fax: +353 (0)1 4198890

MITSUBISHI ELECTRIC EUROPE B.V. **ITALY**
 Italian Branch
 Viale Colleoni 7
I-20041 Agrate Brianza (MB)
 Phone: +39 039 / 60 53 1
 Fax: +39 039 / 60 53 312

MITSUBISHI ELECTRIC EUROPE B.V. **POLAND**
 Poland Branch
 Krakowska 50
PL-32-083 Balice
 Phone: +48 (0)12 / 630 47 00
 Fax: +48 (0)12 / 630 47 01

MITSUBISHI ELECTRIC EUROPE B.V. **SPAIN**
 Spanish Branch
 Carretera de Rubí 76-80
E-08190 Sant Cugat del Vallés (Barcelona)
 Phone: 902 131121 // +34 935653131
 Fax: +34 935891579

MITSUBISHI ELECTRIC EUROPE B.V. **UK**
 UK Branch
 Travellers Lane
UK-Hatfield, Herts. AL10 8XB
 Phone: +44 (0)1707 / 27 61 00
 Fax: +44 (0)1707 / 27 86 95

MITSUBISHI ELECTRIC CORPORATION **JAPAN**
 Office Tower "Z" 14 F
 8-12, 1 chome, Harumi Chuo-Ku
Tokyo 104-6212
 Phone: +81 3 622 160 60
 Fax: +81 3 622 160 75

MITSUBISHI ELECTRIC AUTOMATION, Inc. **USA**
 500 Corporate Woods Parkway
Vernon Hills, IL 60061
 Phone: +1 847 478 21 00
 Fax: +1 847 478 22 53

EUROPEAN REPRESENTATIVES

GEVA **AUSTRIA**
 Wiener Straße 89
AT-2500 Baden
 Phone: +43 (0)2252 / 85 55 20
 Fax: +43 (0)2252 / 488 60

TEHNIKON **BELARUS**
 Oktyabrskaya 16/5, Off. 703-711
BY-220030 Minsk
 Phone: +375 (0)17 / 210 46 26
 Fax: +375 (0)17 / 210 46 26

ESCO DRIVES & AUTOMATION **BELGIUM**
 Culliganlaan 3
BE-1831 Diegem
 Phone: +32 (0)2 / 717 64 30
 Fax: +32 (0)2 / 717 64 31

Koning & Hartman b.v. **BELGIUM**
 Woluwelaan 31
BE-1800 Vilvoorde
 Phone: +32 (0)2 / 257 02 40
 Fax: +32 (0)2 / 257 02 49

INEA BH d.o.o. **BOSNIA AND HERZEGOVINA**
 Aleja Lipa 56
BA-71000 Sarajevo
 Phone: +387 (0)33 / 921 164
 Fax: +387 (0)33 / 524 539

AKHNATON **BULGARIA**
 4 Andrej Ljapchev Blvd. Pb 21
BG-1756 Sofia
 Phone: +359 (0)2 / 817 6004
 Fax: +359 (0)2 / 97 44 06 1

INEA CR d.o.o. **CROATIA**
 Losinjska 4 a
HR-10000 Zagreb
 Phone: +385 (0)1 / 36 940 -01 / -02 / -03
 Fax: +385 (0)1 / 36 940 -03

AutoCont C.S. s.r.o. **CZECH REPUBLIC**
 Technologická 374/6
CZ-708 00 Ostrava-Pustkovce
 Phone: +420 595 691 150
 Fax: +420 595 691 199

B:ELECTRIC, s.r.o. **CZECH REPUBLIC**
 Mladoboleslavská 812
CZ-197 00 Praha 19 - Kbely
 Phone: +420 286 850 848, +420 724 317 975
 Fax: +420 286 850 850

Beijer Electronics A/S **DENMARK**
 Lykkegårdsvej 17
DK-4000 Roskilde
 Phone: +45 (0)46 / 75 76 66
 Fax: +45 (0)46 / 75 56 26

Beijer Electronics Eesti OÜ **ESTONIA**
 Pärnu mnt.160i
EE-11317 Tallinn
 Phone: +372 (0)6 / 51 81 40
 Fax: +372 (0)6 / 51 81 49

Beijer Electronics OY **FINLAND**
 Peltoie 37
FIN-28400 Ulvila
 Phone: +358 (0)207 / 463 540
 Fax: +358 (0)207 / 463 541

UTEKO A.B.E.E. **GREECE**
 5, Mavrogenous Str.
GR-18542 Piraeus
 Phone: +30 211 / 1206 900
 Fax: +30 211 / 1206 999

MELTRADE Kft. **HUNGARY**
 Fertő utca 14.
HU-1107 Budapest
 Phone: +36 (0)1 / 431-9726
 Fax: +36 (0)1 / 431-9727

Beijer Electronics SIA **LATVIA**
 Rītausmas iela 23
LV-1058 Riga
 Phone: +371 (0)784 / 2280
 Fax: +371 (0)784 / 2281

Beijer Electronics UAB **LITHUANIA**
 Savanorių Pr. 187
LT-02300 Vilnius
 Phone: +370 (0)5 / 232 3101
 Fax: +370 (0)5 / 232 2980

EUROPEAN REPRESENTATIVES

ALFATRADE Ltd. **MALTA**
 99, Paola Hill
Malta- Paola PLA 1702
 Phone: +356 (0)21 / 697 816
 Fax: +356 (0)21 / 697 817

INTEHSIS srl **MOLDOVA**
 bld. Traian 23/1
MD-2060 Kishinev
 Phone: +373 (0)22 / 66 4242
 Fax: +373 (0)22 / 66 4280

HIFLEX AUTOM.TECHNIEK B.V. **NETHERLANDS**
 Wolweverstraat 22
NL-2984 CD Ridderkerk
 Phone: +31 (0)180 - 46 60 04
 Fax: +31 (0)180 - 44 23 55

Koning & Hartman b.v. **NETHERLANDS**
 Haarlbergweg 21-23
NL-1101 CH Amsterdam
 Phone: +31 (0)20 / 587 76 00
 Fax: +31 (0)20 / 587 76 05

Beijer Electronics AS **NORWAY**
 Postboks 487
NO-3002 Drammen
 Phone: +47 (0)32 / 24 30 00
 Fax: +47 (0)32 / 84 85 77

Sirius Trading & Services srl **ROMANIA**
 Aleea Lacul Morii Nr. 3
RO-060841 Bucuresti, Sector 6
 Phone: +40 (0)21 / 430 40 06
 Fax: +40 (0)21 / 430 40 02

Craft Con. & Engineering d.o.o. **SERBIA**
 Bulevar Svetog Cara Konstantina 80-86
SER-18106 Nis
 Phone: +381 (0)18 / 292-24-4/5
 Fax: +381 (0)18 / 292-24-4/5

INEA SR d.o.o. **SERBIA**
 Izletnička 10
SER-113000 Smederevo
 Phone: +381 (0)26 / 617 163
 Fax: +381 (0)26 / 617 163

AutoCont Control s.r.o. **SLOVAKIA**
 Radlinského 47
SK-02601 Dolny Kubin
 Phone: +421 (0)43 / 5868210
 Fax: +421 (0)43 / 5868210

CS MTrade Slovensko, s.r.o. **SLOVAKIA**
 Vajanskeho 58
SK-92101 Piestany
 Phone: +421 (0)33 / 7742 760
 Fax: +421 (0)33 / 7735 144

INEA d.o.o. **SLOVENIA**
 Stegne 11
SI-1000 Ljubljana
 Phone: +386 (0)1 / 513 8100
 Fax: +386 (0)1 / 513 8170

Beijer Electronics AB **SWEDEN**
 Box 426
SE-20124 Malmö
 Phone: +46 (0)40 / 35 86 00
 Fax: +46 (0)40 / 93 23 01

Omni Ray AG **SWITZERLAND**
 Im Schörl 5
CH-8600 Dübendorf
 Phone: +41 (0)44 / 802 28 80
 Fax: +41 (0)44 / 802 28 28

GTS **TURKEY**
 Bayraktar Bulvari Nutuk Sok. No:5
TR-34775 Yukarı Dudullu-Ümraniye-İSTANBUL
 Phone: +90 (0)216 526 39 90
 Fax: +90 (0)216 526 3995

CSC Automation Ltd. **UKRAINE**
 4-B, M. Raskovoyi St.
UA-02660 Kiev
 Phone: +380 (0)44 / 494 33 55
 Fax: +380 (0)44 / 494-33-66

EURASIAN REPRESENTATIVES

Kazpromautomatiks Ltd. **KAZAKHSTAN**
 Mustafina Str. 7/2
KAZ-470046 Karaganda
 Phone: +7 7212 / 50 11 50
 Fax: +7 7212 / 50 11 50

MIDDLE EAST REPRESENTATIVES

TEXEL ELECTRONICS Ltd. **ISRAEL**
 2 Ha'umanut, P.O.B. 6272
IL-42160 Netanya
 Phone: +972 (0)9 / 863 39 80
 Fax: +972 (0)9 / 885 24 30

CEG INTERNATIONAL **LEBANON**
 Cebaco Center/Block A Autostrade DORA
Lebanon - Beirut
 Phone: +961 (0)1 / 240 430
 Fax: +961 (0)1 / 240 438

AFRICAN REPRESENTATIVE

CBI Ltd. **SOUTH AFRICA**
 Private Bag 2016
ZA-1600 Isando
 Phone: +27 (0)11 / 977 0770
 Fax: +27 (0)11 / 977 0761