

# **MELSEC Q series**

Programmable Controller

User's Manual  
(Hardware)

**C Controller Module**  
**Q12DCCPU-V, Q06CCPU-V,**  
**Q06CCPU-V-B**

## ● SAFETY PRECAUTIONS ●

(Read these precautions before using this product.)

Before using this product, please read this manual and the relevant manuals carefully and pay full attention to safety to handle the product correctly.

In this manual, the safety precautions are classified into two levels: "DANGER" and "CAUTION".



Indicates that incorrect handling may cause hazardous conditions, resulting in death or severe injury.



Indicates that incorrect handling may cause hazardous conditions, resulting in minor or moderate injury or property damage.

Under some circumstances, failure to observe the precautions given under "  CAUTION" may lead to serious consequences.

Observe the precautions of both levels because they are important for personal and system safety.

Make sure that the end users read this manual and then keep the manual in a safe place for future reference.

## [DESIGN PRECAUTIONS]

### DANGER

- Configure safety circuits external to the C Controller module to ensure that the entire system operates safely even when a fault occurs in the external power supply or the C Controller module. Failure to do so may result in an accident due to an incorrect output or malfunction.
  - (1) Configure external safety circuits, such as an emergency stop circuit, protection circuit, and protective interlock circuit for forward/reverse operation or upper/lower limit positioning.
  - (2) If the following error status (a) or (b) occurs, the system will behave as shown below.
    - (a) When overcurrent or overvoltage protection of the power supply module is activated, the outputs (Y) from the user program and writing to the buffer memory are disabled, and all outputs are turned off.
    - (b) When the C Controller module detects an error such as a watchdog timer error by the self-diagnostic function, the outputs (Y) from the user program and writing to the buffer memory are disabled. Whether to hold or turn off all outputs can be set by a parameter.

All outputs may turn on when an error occurs in the part, such as I/O control part, where the C Controller module cannot detect any error. To ensure safety operation in such a case, provide a safety mechanism or a fail-safe circuit external to the C Controller module. For a fail-safe circuit example, refer to Chapter 3 of this manual.

- (3) Outputs may remain on or off due to a failure of an output module relay or transistor.

Configure an external circuit for monitoring output signals that could cause a serious accident.
- In an output module, when a load current exceeding the rated current or an overcurrent caused by a load short-circuit flows for a long time, it may cause smoke and fire. To prevent this, configure an external safety circuit, such as a fuse.
- Configure a circuit so that the C Controller system is turned on first and then the external power supply. If the external power supply is turned on first, an accident may occur due to an incorrect output or malfunction.

## [DESIGN PRECAUTIONS]

### DANGER

- For the operating status of each station after a communication failure, refer to the relevant manuals for the network.  
Incorrect output or malfunction due to a communication failure may result in an accident.
- For the following controls, configure an interlock circuit in the user program to ensure that the entire system will always operate safely.
  - (1) Changing data of the running C Controller module from the development environment (personal computer) connected
  - (2) Changing the operating status
  - (3) Operating from the development environment (personal computer)  
Especially, in the case of a control from an external device to a remote C Controller module, immediate action cannot be taken for a problem on the C Controller module due to a communication failure.  
To prevent this, configure an interlock circuit in the user program, and determine corrective actions to be taken between the external device and C Controller module in case of a communication failure.
- When configuring the system, do not leave any slot empty on the base unit.  
If a slot is to be left empty, attach a blank cover (QG60).  
Failure to do so may cause internal parts of the mounted modules to fly apart during a short-circuit test or when an excess current or voltage is applied to an external I/O part by mistake.

### CAUTION

- Do not install the control lines or communication cables together with the main circuit lines or power cables.  
Keep a distance of 100mm (3.94 inches) or more between them.  
Failure to do so may result in malfunction due to noise.
- When a device such as a lamp, heater, or solenoid valve is controlled through an output module, a large current (approximately ten times greater than normal) may flow when the output is turned from off to on. Take measures such as replacing the module with one having a sufficient current rating.

## [INSTALLATION PRECAUTIONS]

### CAUTION

- Use the C Controller module in an environment that meets the general specifications in this manual.  
Failure to do so may result in electric shock, fire, malfunction, or damage to or deterioration of the product.
- To mount the module, while pressing the module mounting lever located in the lower part of the module, fully insert the module fixing projection(s) into the hole(s) in the base unit and press the module until it snaps into place. Incorrect mounting may cause malfunction, failure or drop of the module. When using the module in an environment of frequent vibrations, fix the module with a screw.  
Tighten the screw within the specified torque range.  
Undertightening can cause drop of the screw, short circuit or malfunction.  
Overtightening can damage the screw and/or module, resulting in drop, short circuit, or malfunction.
- When using an extension cable, connect it to the connector of the base unit or module securely.  
Check the connection for looseness.  
Poor contact may cause incorrect input or output.
- When using a CompactFlash card, fully insert it into the CompactFlash card slot.  
Check that it is inserted completely.  
Poor contact may cause malfunction.
- Shut off the external power supply for the system in all phases before mounting or removing the module.  
Failure to do so may result in damage to the product.
- Do not directly touch any conductive part of the module.  
Doing so can cause malfunction or failure of the module.

## [WIRING PRECAUTIONS]

### DANGER

- Shut off the external power supply for the system in all phases before wiring.  
Failure to do so may result in electric shock or damage to the product.
- After wiring, attach the included terminal cover to the module before turning it on for operation.  
Failure to do so may result in electric shock.

## [WIRING PRECAUTIONS]

### CAUTION

- Ground the FG and LG terminals to the protective ground conductor dedicated to the programmable controller.  
Failure to do so may result in electric shock or malfunction.
- Prevent foreign matter such as dust or wire chips from entering the module.  
Such foreign matter can cause a fire, failure, or malfunction.
- Check the rated voltage and terminal layout before wiring to the module, and connect the cables correctly.  
Connecting a power supply with a different voltage rating or incorrect wiring may cause a fire or failure.
- Securely connect the Ethernet and RS-232 cables to respective connectors of the C Controller module.
- Tighten the terminal screw within the specified torque range.  
Undertightening can cause short circuit, fire, or malfunction.  
Overtightening can damage the screw and/or module, resulting in drop, short circuit, or malfunction.
- Place the communication and power cables in a duct or clamp them.  
If not, dangling cable may swing or inadvertently be pulled, resulting in damage to the module or cables or malfunctions due to poor contact.
- When disconnecting a communication or power cable from the module, do not hold and pull the cable part.  
Doing so may cause malfunction or damage to the module or cable.  
For a cable with connector, hold the connected connector by hand to disconnect the cable.  
For a cable with screw, loosen the screw to disconnect the cable.
- Do not connect outputs of multiple power supply modules in parallel.  
The power supply modules may produce heat, causing a fire or failure.
- Connectors for external connection must be crimped or pressed with the tool specified by the manufacturer, or must be correctly soldered.  
For the tool, refer to the user's manual for the relevant I/O module.  
Incomplete connections could result in short circuit, fire or malfunction.

## [STARTUP AND MAINTENANCE PRECAUTIONS]

### DANGER

- Do not touch any terminal while power is on.  
Doing so will cause electric shock.
- Correctly connect the battery connector.  
Do not charge, disassemble, heat, short-circuit, solder, or throw the battery into the fire.  
Doing so will cause the battery to produce heat, explode, or ignite, resulting in injury and fire.
- Shut off the external power supply for the system in all phases before cleaning the module or retightening the terminal screws or module fixing screws.  
Failure to do so may result in electric shock.  
Undertightening the terminal screws can cause short circuit or malfunction.  
Overtightening can damage the screw and/or module, resulting in drop, short circuit, or malfunction.
- For the following controls, configure an interlock circuit in the user program to ensure that the entire system will always operate safely.
  - (1) Changing data of the running C Controller module from the development environment (personal computer) connected
  - (2) Changing the operating status
  - (3) Operating from the development environment (personal computer)  
Especially, in the case of a control from an external device to a remote C Controller module, immediate action cannot be taken for a problem on the C Controller module due to a communication failure.  
To prevent this, configure an interlock circuit in the user program, and determine corrective actions to be taken between the external device and C Controller module in case of a communication failure.

## [STARTUP AND MAINTENANCE PRECAUTIONS]

### CAUTION

- Do not disassemble or modify the modules.  
Doing so may cause failure, malfunction, injury, or a fire.
- Before performing online operations (especially, program modification, forced output, and operation status change) for the running C Controller module from the peripheral connected, read relevant manuals carefully and ensure the safety.  
Improper operation may damage machines or cause accidents.
- Shut off the external power supply for the system in all phases before mounting or removing the module.  
Failure to do so may cause the module to fail or malfunction.
- After the first use of the product, do not mount/remove the module to/from the base unit more than 50 times. (IEC 61131-2 compliant)  
Exceeding the limit of 50 times may cause malfunction.
- Use any radio communication device such as a cellular phone or PHS (Personal Handy-phone System) more than 25cm (9.85 inches) away in all directions from the C Controller system.  
Failure to do so may cause malfunction.
- Do not drop or apply shock to the battery to be installed in the module.  
Doing so may damage the battery, causing the battery fluid to leak inside the battery.  
If the battery is dropped or any shock is applied to it, dispose of it without using.
- Before handling the module, touch a grounded metal object to discharge the static electricity from the human body.  
Failure to do so may cause the module to fail or malfunction.



## [DISPOSAL PRECAUTIONS]

### CAUTION

- When disposing of this product, treat it as industrial waste.  
When disposing of batteries, separate them from other wastes according to the local regulations.  
(For details of the battery directive in EU member states, refer to the C Controller Module User's Manual (Hardware Design, Function Explanation).)

## [TRANSPORTATION PRECAUTIONS]

### CAUTION

- When transporting lithium batteries, follow the transportation regulations.  
(For details of the regulated models, refer to the C Controller Module User's Manual (Hardware Design, Function Explanation).)



---

---

## CONTENTS

---

---

1. OVERVIEW.....	1
2. GENERAL SPECIFICATIONS.....	3
3. FAIL-SAFE CIRCUIT .....	5

## About Manuals

The following manuals are also related to this product.  
If necessary, please place an order referring to the table below.

Related Manuals
-----------------

Manual name	Manual Number (Model code)
C Controller Module User's Manual (Hardware Design, Function Explanation) Describes the system configurations, specifications, functions, handling instructions, wiring, and troubleshooting of the C Controller module. (Sold separately)	SH-080766ENG (13JZ17)
C Controller Module User's Manual (Utility Operation, Programming) Describes installation/uninstallation of SW□PVC-CCPU, utility operation, and functions and programming. (Sold separately)	SH-080767ENG (13JZ18)
QCPU User's Manual (Hardware Design, Maintenance and Inspection) Provides the specifications of CPU modules, power supply modules, base units, extension cables, and memory cards. (Sold separately)	SH-080483ENG (13JR73)
I/O Module Type Building Block User's Manual Describes the specifications of the I/O modules and external wiring. (Sold separately)	SH-080042 (13JL99)

---

---

# 1. OVERVIEW

---

---

(1) About this manual

This manual describes installation of the C Controller module and wiring to other devices, and mainly explains the C Controller module itself.

For the information listed below, refer to the QCPU User's Manual (Hardware Design, Maintenance and Inspection).

When reading the manual, note that the terms "CPU module" and "programmable controller" must be regarded as "C Controller module" and "C Controller system" accordingly.

Item	Refer to
Checking power supply module specifications	Chapter 5
Checking base unit specifications	Chapter 6
Compliance of the C Controller system with the EMC and Low Voltage Directives	Chapter 9*1
Mounting the module	Section 10.3
Wiring the power supply module	Section 10.6
Checking part names of the power supply module	Section 5.3

- \*1 For compliance with the EMC directive, the C Controller module must satisfy the requirements on noise immunity of Ethernet, RS-232, and USB cables. For details, refer to the C Controller Module User's Manual (Hardware Design, Function Explanation).

For the specifications and connecting methods of I/O modules, refer to the I/O Module Type Building Block User's Manual.

(2) Packing lists

The following items are included in the package of the C Controller module.

(a) Q12DCCPU-V

Item	Model	Quantity
C Controller module	Q12DCCPU-V	1
Battery	Q6BAT	1
This manual	-	1

(b) Q06CCPU-V

Item	Model	Quantity
C Controller module	Q06CCPU-V	1
Battery	Q6BAT	1
This manual	-	1

(c) Q06CCPU-V-B

Item	Model	Quantity
C Controller module	Q06CCPU-V-B	1
Battery	Q6BAT	1
This manual	-	1

(3) Generic terms and abbreviations used in this manual

Unless otherwise specified, this manual uses the following generic terms and abbreviations to explain the C Controller module.

Generic term/abbreviation	Description
Q12DCCPU-V	Abbreviation for the Q12DCCPU-V C Controller module
Q06CCPU-V	Abbreviation for the Q06CCPU-V C Controller module
Q06CCPU-V-B	Abbreviation for the Q06CCPU-V-B C Controller module
C Controller module	Generic term for the Q12DCCPU-V, Q06CCPU-V, and Q06CCPU-V-B
C Controller system	Generic term for the system that uses the C Controller module

## 2. GENERAL SPECIFICATIONS

The following is the specifications common to the relevant module models.

Item	Specifications <sup>6</sup>					
Operating ambient temperature	0 to 55°C					
Storage ambient temperature	-25 to 75°C*3					
Operating ambient humidity	5 to 95%RH*4, Non-condensing					
Storage ambient humidity	5 to 95%RH*4, Non-condensing					
Vibration resistance	Conforming to JIS B 3502, IEC 61131-2	-	Frequency	Fixed acceleration	Half amplitude	Sweep count
		Under intermittent vibration	5 to 9Hz	-	3.5mm (0.14inch)	10 times each in X, Y and Z directions
			9 to 150Hz	9.8m/s <sup>2</sup>	-	
		Under continuous vibration	5 to 9Hz	-	1.75mm (0.069inch)	-
9 to 150Hz	4.9m/s <sup>2</sup>		-			
Shock resistance	Conforming to JIS B 3502, IEC 61131-2 (147m/s <sup>2</sup> , 3 times in each of 3 directions, X, Y and Z)					
Operating ambience	No corrosive gases					
Operating altitude*5	2000m (6562ft.) or less					
Installation location	Inside control panel					
Overvoltage category*1	II or lower					
Pollution degree*2	2 or lower					

- \*1 Indicates the level of the power source (the location ranging from the public power distribution network to the machinery within premises) which is used to run the equipment.  
Category II applies to equipment to which electric power is supplied from the fixed facilities.  
The surge withstand voltage of equipment with a rated voltage of up to 300V is 2500V.
- \*2 Signifies the level of possible conductive pollution in the environment where the equipment is used.  
Pollution Degree 2 is nonconductive pollution although a temporary conductivity caused by condensation can be expected.
- \*3 The storage ambient temperature is -20 to 75°C if the system includes an AnS series module.
- \*4 The operating and storage ambient humidities are 10 to 90%RH if the system includes an AnS series module.
- \*5 Do not use or store the C Controller system under pressure higher than the atmospheric pressure at sea level.  
Doing so can cause malfunction.  
For use in a pressurized environment, please consult your local Mitsubishi representative.
- \*6 When installing a commercial CompactFlash card into the C Controller module, please follow the specifications of the C Controller module or the CompactFlash card, whichever is lower.



---

### 3. FAIL-SAFE CIRCUIT

---

 **DANGER**

- Configure safety circuits external to the C Controller module to ensure that the entire system operates safely even when a fault occurs in the external power supply or the C Controller module.  
Failure to do so may result in an accident due to an incorrect output or malfunction.
  - (1) Configure external safety circuits, such as an emergency stop circuit, protection circuit, and protective interlock circuit for forward/reverse operation or upper/lower limit positioning.
  - (2) If the following error status (a) or (b) occurs, the system will behave as shown below.
    - (a) When overcurrent or overvoltage protection of the power supply module is activated, the outputs (Y) from the user program and writing to the buffer memory are disabled, and all outputs are turned off.
    - (b) When the C Controller module detects an error such as a watchdog timer error by the self-diagnostic function, the outputs (Y) from the user program and writing to the buffer memory are disabled. Whether to hold or turn off all outputs can be set by a parameter.

All outputs may turn on when an error occurs in the part, such as I/O control part, where the C Controller module cannot detect any error. To ensure safety operation in such a case, provide a safety mechanism or a fail-safe circuit external to the C Controller module.

- (3) Outputs may remain on or off due to a failure of an output module relay or transistor.  
Configure an external circuit for monitoring output signals that could cause a serious accident.

## DANGER

- In an output module, when a load current exceeding the rated current or an overcurrent caused by a load short-circuit flows for a long time, it may cause smoke and fire. To prevent this, configure an external safety circuit, such as a fuse.
- Configure a circuit so that the C Controller system is turned on first and then the external power supply. If the external power supply is turned on first, an accident may occur due to an incorrect output or malfunction.
- For the operating status of each station after a communication failure, refer to the relevant manuals for the network.  
Incorrect output or malfunction due to a communication failure may result in an accident.
- For the following controls, configure an interlock circuit in the user program to ensure that the entire system will always operate safely.
  - (1) Changing data of the running C Controller module from the development environment (personal computer) connected
  - (2) Changing the operating status
  - (3) Operating from the development environment (personal computer)  
Especially, in the case of control from an external device to a remote C Controller module, immediate action cannot be taken for a problem on the C Controller module due to a communication failure.  
To prevent this, configure an interlock circuit in the user program, and determine corrective actions to be taken between the external device and C Controller module in case of a communication failure.

## CAUTION

- Do not install the control lines or communication cables together with the main circuit lines or power cables.  
Keep a distance of 100mm (3.94 inches) or more between them.  
Failure to do so may result in malfunction due to noise.
- When a device such as a lamp, heater, or solenoid valve is controlled through an output module, a large current (approximately ten times greater than normal) may flow when the output is turned from off to on. Take measures such as replacing the module with one having a sufficient current rating.

When the C Controller system is powered on/off, the control output may not operate normally for a moment because of the delay or rise time difference between the C Controller system power supply and the external power supply (especially DC) for the control target.

In the case of a DC output module, for example, when power is applied to the external power supply for the control target first and then the C Controller system power supply, the DC output module may temporarily generate incorrect output at power-on of the C Controller system.

Therefore, it is necessary to configure the circuit by which power is applied to the C Controller system first.

Also, abnormal operation may occur due to failure of the external power supply or C Controller module.

To prevent such abnormal operation from resulting in failure of the entire system, from a viewpoint of fail-safe system operation, configure external circuits for the areas where an abnormal operation will lead to mechanical damage and/or accidents (emergency stop circuit, protection circuit, interlock circuit, etc.)

A circuit example for system design is provided on the next page.



- \*1 Program the system so that the following operation will be performed at start-up of the C Controller module.
- 1) When a battery voltage drop is detected, Ym is turned on.  
In the program, Ym must be turned on by the QBF\_Y\_Out\_BitEx function when "Built-in battery error status" of the QBF\_ReadStatusEx function is set to 1 (battery error).
  - 2) Yn is turned on at start of the user program.  
In the program, Yn is turned on to release the interlock at start of the user program of the C Controller module.
- \*2 Program the system so that the following operation will be performed at start-up of the C Controller module.
- 1) When a battery voltage drop is detected, Ym is turned on.  
In the program, Ym must be turned on by the QBF\_Y\_Out\_BitEx function when "Built-in battery error status" of the QBF\_ReadStatusEx function is set to 1 (battery error).
  - 2) Yn is turned on at start of the user program.  
In the program, Yn must be turned on to release the interlock at start of the user program of the C Controller module.
  - 3) After XM turns on and the DC input signal is established, system processing is started.  
Create a program so that system processing will start when the DC input signal establishment time has elapsed after turn-on of XM (the status can be confirmed by the QBF\_X\_In\_BitEx function). (The DC input signal establishment time is the time taken from "on" of RA2 to 100% establishment of the DC input signal. Set this time to 0.5 seconds.)  
However, when a voltage relay is used for RA2, the DC input signal establishment time need not be set in the user program.

- (2) A circuit example for system design (when using the  $\overline{\text{ERR}}$  contact of the power supply module)

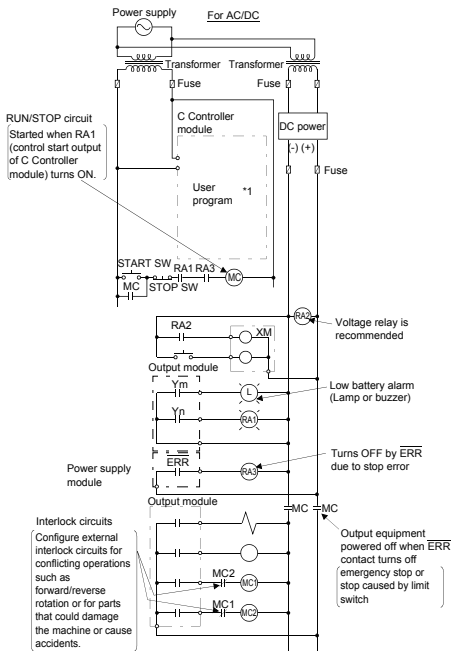

The power-up procedure is as follows:

#### For AC/DC

- [1] Turn on the power.
- [2] Set the C Controller module to "RUN".
- [3] When DC power is applied, RA2 is turned on.
- [4] When RA2 turns on, XM is turned on. Upon 100% establishment of the DC input signal, processing is started by the user program<sup>2</sup>.
- [5] Turn on the start switch.
- [6] When the magnetic contact (MC) turns on, the output equipment is driven by the user program.

\*1 Program the system so that the following operation will be performed at start-up of the C Controller module.

1) When a battery voltage drop is detected, Ym is turned on.  
In the program, Ym must be turned on by the QBF\_Y\_Out\_BitEx function when "Built-in battery error status" of the QBF\_ReadStatusEx function is set to 1 (battery error).

2) Yn is turned on at start of the user program.  
In the program, Yn must be turned on to release the interlock at start of the user program of the C Controller module.

3) After XM turns on and the DC input signal is established, system processing is started.

Create a program so that system processing will start when the DC input signal establishment time has elapsed after turn-on of XM (the status can be confirmed by the QBF\_X\_In\_BitEx function). (The DC input signal establishment time is the time taken from "on" of RA2 to 100% establishment of the DC input signal. Set this time to 0.5 seconds.)

However, when a voltage relay is used for RA2, the DC input signal establishment time need not be set in the user program.

(3) Fail-safe measures for C Controller system failure

The C Controller module can detect its own failure by the self-diagnostic function.

However, it may not be able to detect a failure that occurred in an I/O control part.

In such a case, all the I/O may turn on or off depending on the failure, and normal operation and safety of the control target may not be ensured.

Though Mitsubishi products are manufactured under strict quality control, it is recommended to configure an external fail-safe circuit so that a C Controller system failure will not result in mechanical damage or accidents.

The following shows a system example and a fail-safe circuit example.

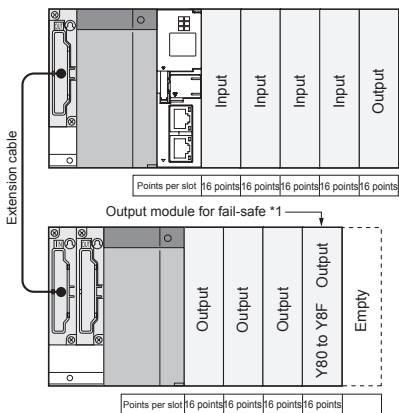

- \*1 The output module for fail-safe use should be installed to the last slot of the system. (Y80 to Y8F in the above system)



<Fail-safe circuit example>

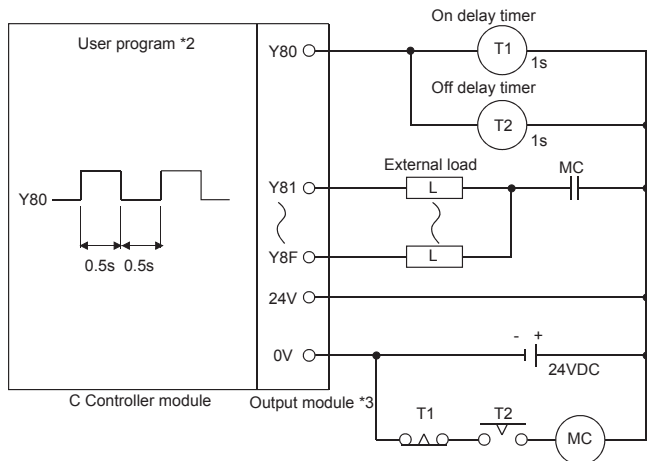

- \*2 Program it so that Y80 alternates between ON and OFF at intervals of 0.5 seconds. (Use the QBF\_Y\_Out\_BitEx function to set Y80 to on/off.)
- \*3 Since Y80 repeatedly turns on and off at 0.5s intervals, use a non-contact output module (a transistor in the case above).

Ethernet is a trademark of Xerox Corporation.  
CompactFlash is a trademark of SanDisk Corporation.  
Other company and product names are trademarks or registered trademarks of their respective companies.

## Warranty

Mitsubishi will not be held liable for damage caused by factors found not to be the cause of Mitsubishi; machine damage or lost profits caused by faults in the Mitsubishi products; damage, secondary damage, accident compensation caused by special factors unpredictable by Mitsubishi; damages to products other than Mitsubishi products; and to other duties.

### For safe use

- This product has been manufactured as a general-purpose part for general industries, and has not been designed or manufactured to be incorporated in a device or system used in purposes related to human life.
- Before using the product for special purposes such as nuclear power, electric power, aerospace, medicine or passenger movement vehicles, consult with Mitsubishi.
- This product has been manufactured under strict quality control. However, when installing the product where major accidents or losses could occur if the product fails, install appropriate backup or failsafe functions in the system.

Country/Region	Sales office/Tel	Country/Region	Sales office/Tel
U.S.A	Mitsubishi Electric Automation Inc. 500 Corporate Woods Parkway Vernon Hills, IL 60061, U.S.A. Tel : +1-847-478-2100	Hong Kong	Mitsubishi Electric Automation (Hong Kong) Ltd. 10th Floor, Manulife Tower, 169 Electric Road, North Point, Hong Kong Tel : +852-2887-8870
Brazil	MELCO-TEC Rep. Com.e Assessoria Tecnica Ltda. Rua Correia Dias, 184, Edificio Paraíso Trade Center-8 andar Paraíso, Sao Paulo, SP Brazil Tel : +55-11-5908-8331	China	Mitsubishi Electric Automation (Shanghai) Ltd. 4/F Zhi Fu Plaza, No.80 Xin Chang Road, Shanghai 200003, China Tel : +86-21-6120-0808
Germany	Mitsubishi Electric Europe B.V. German Branch Gothaer Strasse 8 D-40880 Ratingen, GERMANY Tel : +49-2102-486-0	Taiwan	Setuyo Enterprise Co., Ltd. 6F No.105 Wu-Kung 3rd.Rd, Wu-Ku Hsiang, Taipei Hsine, Taiwan Tel : +886-2-2299-2499
U.K	Mitsubishi Electric Europe B.V. UK Branch Travellers Lane, Hatfield, Hertfordshire., AL10 8XB, U.K. Tel : +44-1707-276100	Korea	Mitsubishi Electric Automation Korea Co., Ltd. 1480-6, Gayang-dong, Gangseo-ku Seoul 157-200, Korea Tel : +82-2-3660-9552
Italy	Mitsubishi Electric Europe B.V. Italian Branch Centro Dir. Colleoni, Pal. Perseo-Ing.2 Via Paracelso 12, I-20041 Agrate Brianza., Milano, Italy Tel : +39-039-60531	Singapore	Mitsubishi Electric Asia Pte, Ltd. 307 Alexandra Road #05-01/02, Mitsubishi Electric Building, Singapore 159943 Tel : +65-6470-2460
Spain	Mitsubishi Electric Europe B.V. Spanish Branch Carretera de Rubi 76-80, E-08190 Sant Cugat del Valles, Barcelona, Spain Tel : +34-93-565-3131	Thailand	Mitsubishi Electric Automation (Thailand) Co., Ltd. Bang-Chan Industrial Estate No.11 Moo 4, Serithai Rd, T.Kannayao, A.Kannayao, Bangkok 10230 Thailand Tel : +66-2-517-1326
France	Mitsubishi Electric Europe B.V. French Branch 25, Boulevard des Bouvets, F-92741 Nanterre Cedex, France TEL: +33-1-5568-5568	Indonesia	P.T. Autotekindo Sumber Makmur Muara Karang Selatan, Block A/Utara No.1 Kav. No.11 Kawasan Industri Pergudangan Jakarta - Utara 14440, P.O.Box 5045 Jakarta, 11050 Indonesia Tel : +62-21-6630833
South Africa	Circuit Breaker Industries Ltd. Private Bag 2016, ZA-1600 Isando, South Africa Tel : +27-11-928-2000	India	Messung Systems Pvt. Ltd. Electronic Sadan NO:III Unit No15, M.I.D.C Bhosari, Pune-411026, India Tel : +91-20-2712-3130
		Australia	Mitsubishi Electric Australia Pty. Ltd. 348 Victoria Road, Rydalmere, N.S.W 2116, Australia Tel : +61-2-9684-7777

## MITSUBISHI ELECTRIC CORPORATION

HEAD OFFICE : TOKYO BUILDING, 2-7-3 MARUNOUCHI, CHYODA-KU, TOKYO 100-8310, JAPAN  
NAGOYA WORKS : 1-14, YADA-MINAMI 5-CHOME, HIGASHI-KU, NAGOYA, JAPAN

When exported from Japan, this manual does not require application to the Ministry of Economy, Trade and Industry for service transaction permission.

Specifications subject to change without notice.



**HEADQUARTERS**

**MITSUBISHI ELECTRIC EUROPE B.V. EUROPE**  
 German Branch  
 Gothaer Straße 8  
**D-40880 Ratingen**  
 Phone: +49 (0)2102 / 486-0  
 Fax: +49 (0)2102 / 486-1120

**MITSUBISHI ELECTRIC EUROPE B.V. CZECH REPUBLIC**  
 Czech Branch  
 Avenir Business Park, Radlická 714/113a  
**CZ-158 00 Praha 5**  
 Phone: +420 (0)251 551 470  
 Fax: +420 (0)251-551-471

**MITSUBISHI ELECTRIC EUROPE B.V. FRANCE**  
 French Branch  
 25, Boulevard des Bouvets  
**F-92741 Nanterre Cedex**  
 Phone: +33 (0)1 / 55 68 55 68  
 Fax: +33 (0)1 / 55 68 57 57

**MITSUBISHI ELECTRIC EUROPE B.V. IRELAND**  
 Irish Branch  
 Westgate Business Park, Ballymount  
**IRL-Dublin 24**  
 Phone: +353 (0)1 4198800  
 Fax: +353 (0)1 4198890

**MITSUBISHI ELECTRIC EUROPE B.V. ITALY**  
 Italian Branch  
 Viale Colleoni 7  
**I-20041 Agrate Brianza (MB)**  
 Phone: +39 039 / 60 53 1  
 Fax: +39 039 / 60 53 312

**MITSUBISHI ELECTRIC EUROPE B.V. POLAND**  
 Poland Branch  
 Krakowska 50  
**PL-32-083 Balice**  
 Phone: +48 (0)12 / 630 47 00  
 Fax: +48 (0)12 / 630 47 01

**MITSUBISHI ELECTRIC EUROPE B.V. SPAIN**  
 Spanish Branch  
 Carretera de Rubí 76-80  
**E-08190 Sant Cugat del Vallés (Barcelona)**  
 Phone: 902 131121 // +34 935653131  
 Fax: +34 935891579

**MITSUBISHI ELECTRIC EUROPE B.V. UK**  
 UK Branch  
 Travellers Lane  
**UK-Hatfield, Herts. AL10 8XB**  
 Phone: +44 (0)1707 / 27 61 00  
 Fax: +44 (0)1707 / 27 86 95

**MITSUBISHI ELECTRIC CORPORATION JAPAN**  
 Office Tower "Z" 14 F  
 8-12, 1 chome, Harumi Chuo-Ku  
**Tokyo 104-6212**  
 Phone: +81 3 622 160 60  
 Fax: +81 3 622 160 75

**MITSUBISHI ELECTRIC AUTOMATION, Inc. USA**  
 500 Corporate Woods Parkway  
**Vernon Hills, IL 60061**  
 Phone: +1 847 478 21 00  
 Fax: +1 847 478 22 53

**EUROPEAN REPRESENTATIVES**

**AUSTRIA**  
 GEVA  
 Wiener Straße 89  
**AT-2500 Baden**  
 Phone: +43 (0)2252 / 85 55 20  
 Fax: +43 (0)2252 / 488 60

**BELARUS**  
 TEHNIKON  
 Oktyabrskaya 16/5, Off. 703-711  
**BY-220030 Minsk**  
 Phone: +375 (0)17 / 210 46 26  
 Fax: +375 (0)17 / 210 46 26

**BELGIUM**  
 ESCO DRIVES & AUTOMATION  
 Culliganlaan 3  
**BE-1831 Diegem**  
 Phone: +32 (0)2 / 717 64 30  
 Fax: +32 (0)2 / 717 64 31

**BELGIUM**  
 Koning & Hartman b.v.  
 Woluwelaan 31  
**BE-1800 Vilvoorde**  
 Phone: +32 (0)2 / 257 02 40  
 Fax: +32 (0)2 / 257 02 49

**BOSNIA AND HERZEGOVINA**  
 INEA BH d.o.o.  
 Aleja Lipa 56  
**BA-71000 Sarajevo**  
 Phone: +387 (0)33 / 921 164  
 Fax: +387 (0)33 / 524 539

**BULGARIA**  
 AKHNATON  
 4 Andrej Ljapchev Blvd. Pb 21  
**BG-1756 Sofia**  
 Phone: +359 (0)2 / 817 6004  
 Fax: +359 (0)2 / 97 44 06 1

**CROATIA**  
 INEA CR d.o.o.  
 Losinjska 4 a  
**HR-10000 Zagreb**  
 Phone: +385 (0)1 / 36 940 -01 / -02 / -03  
 Fax: +385 (0)1 / 36 940 -03

**CZECH REPUBLIC**  
 AutoCont C.S. s.r.o.  
 Technologická 374/6  
**CZ-708 00 Ostrava-Pustkovce**  
 Phone: +420 595 691 150  
 Fax: +420 595 691 199

**CZECH REPUBLIC**  
 B:ELECTRIC, s.r.o.  
 Mladoboleslavská 812  
**CZ-197 00 Praha 19 - Kbely**  
 Phone: +420 286 850 848, +420 724 317 975  
 Fax: +420 286 850 850

**DENMARK**  
 Beijer Electronics A/S  
 Lykkegårdsvej 17, 1.  
**DK-4000 Roskilde**  
 Phone: +45 (0)46 / 75 76 66  
 Fax: +45 (0)46 / 75 56 26

**ESTONIA**  
 Beijer Electronics Eesti OÜ  
 Pärnu mnt.160i  
**EE-11317 Tallinn**  
 Phone: +372 (0)6 / 51 81 40  
 Fax: +372 (0)6 / 51 81 49

**FINLAND**  
 Beijer Electronics OY  
 Jaakonkatu 2  
**FIN-01620 Vantaa**  
 Phone: +358 (0)207 / 463 500  
 Fax: +358 (0)207 / 463 501

**GREECE**  
 UTECO A.B.E.E.  
 5, Mavrogenous Str.  
**GR-18542 Piraeus**  
 Phone: +30 211 / 1206 900  
 Fax: +30 211 / 1206 999

**HUNGARY**  
 MELTRADE Ltd.  
 Fertő utca 14.  
**HU-1107 Budapest**  
 Phone: +36 (0)1 / 431-9726  
 Fax: +36 (0)1 / 431-9727

**LATVIA**  
 Beijer Electronics SIA  
 Vestienas iela 2  
**LV-1035 Riga**  
 Phone: +371 (0)784 / 2280  
 Fax: +371 (0)784 / 2281

**LITHUANIA**  
 Beijer Electronics UAB  
 Savanorių Pr. 187  
**LT-02300 Vilnius**  
 Phone: +370 (0)5 / 232 3101  
 Fax: +370 (0)5 / 232 2980

**EUROPEAN REPRESENTATIVES**

**MALTA**  
 ALFATRADE Ltd.  
 99, Paola Hill  
**Malta- Paola PLA 1702**  
 Phone: +356 (0)21 / 697 816  
 Fax: +356 (0)21 / 697 817

**MOLDOVA**  
 INTEHSIS srl  
 bld. Traian 23/1  
**MD-2060 Kishinev**  
 Phone: +373 (0)22 / 66 4242  
 Fax: +373 (0)22 / 66 4280

**NETHERLANDS**  
 HIFLEX AUTOM. TECHNIEK B.V.  
 Wolweverstraat 22  
**NL-2984 CD Ridderkerk**  
 Phone: +31 (0)180 - 46 60 04  
 Fax: +31 (0)180 - 44 23 55

**NETHERLANDS**  
 Koning & Hartman b.v.  
 Haarlerbergweg 21-23  
**NL-1101 CH Amsterdam**  
 Phone: +31 (0)20 / 587 76 00  
 Fax: +31 (0)20 / 587 76 05

**NORWAY**  
 Beijer Electronics AS  
 Postboks 487  
**NO-3002 Drammen**  
 Phone: +47 (0)32 / 24 30 00  
 Fax: +47 (0)32 / 84 85 77

**ROMANIA**  
 Sirius Trading & Services srl  
 Aleea Lacul Morii Nr. 3  
**RO-060841 Bucuresti, Sector 6**  
 Phone: +40 (0)21 / 430 40 06  
 Fax: +40 (0)21 / 430 40 02

**SERBIA**  
 Craft Con. & Engineering d.o.o.  
 Bulevar Svetog Cara Konstantina 80-86  
**SER-18106 Nis**  
 Phone: +381 (0)18 / 292-24-4/5  
 Fax: +381 (0)18 / 292-24-4/5

**SERBIA**  
 INEA SR d.o.o.  
 Izletnicka 10  
**SER-113000 Smederevo**  
 Phone: +381 (0)26 / 617 163  
 Fax: +381 (0)26 / 617 163

**SLOVAKIA**  
 AutoCont Control s.r.o.  
 Radlinského 47  
**SK-02601 Dolny Kubin**  
 Phone: +421 (0)43 / 5868210  
 Fax: +421 (0)43 / 5868210

**SLOVAKIA**  
 CS MTrade Slovensko, s.r.o.  
 Vajanskeho 58  
**SK-92101 Piestany**  
 Phone: +421 (0)33 / 7742 760  
 Fax: +421 (0)33 / 7735 144

**SLOVENIA**  
 INEA d.o.o.  
 Stegne 11  
**SI-1000 Ljubljana**  
 Phone: +386 (0)1 / 513 8100  
 Fax: +386 (0)1 / 513 8170

**SWEDEN**  
 Beijer Electronics AB  
 Box 426  
**SE-20124 Malmö**  
 Phone: +46 (0)40 / 35 86 00  
 Fax: +46 (0)40 / 35 86 02

**SWITZERLAND**  
 Econotec AG  
 Hinterdorfstr. 12  
**CH-8309 Nürensdorf**  
 Phone: +41 (0)44 / 838 48 11  
 Fax: +41 (0)44 / 838 48 12

**TURKEY**  
 GTS  
 Bayraktar Bulvari Nutuk Sok. No:5  
**TR-34775 Yukari Dudullu-Umraniye-ISTANBUL**  
 Phone: +90 (0)216 526 39 90  
 Fax: +90 (0)216 526 39 95

**UKRAINE**  
 CSC Automation Ltd.  
 4-B, M. Raskovoyi St.  
**UA-02660 Kiev**  
 Phone: +380 (0)44 / 494 33 55  
 Fax: +380 (0)44 / 494-33-66

**EURASIAN REPRESENTATIVES**

**KAZAKHSTAN**  
 Kazpromautomatiks Ltd.  
 24 Shenkar Str. 7/2  
**KAZ-470046 Karaganda**  
 Phone: +7 7212 / 50 11 50  
 Fax: +7 7212 / 50 11 50

**MIDDLE EAST REPRESENTATIVES**

**ISRAEL**  
 ILAN & GAVISH Ltd.  
 24 Shenkar Str., Kiryat Arie  
**IL-49001 Petah-Tiqva**  
 Phone: +972 (0)3 / 922 18 24  
 Fax: +972 (0)3 / 924 0761

**ISRAEL**  
 TEXEL ELECTRONICS Ltd.  
 2 Ha'umanut, P.O.B. 6272  
**IL-42160 Netanya**  
 Phone: +972 (0)9 / 863 39 80  
 Fax: +972 (0)9 / 885 24 30

**LEBANON**  
 CEG INTERNATIONAL  
 Cebaco Center/Block A Autostrade DORA  
**Lebanon - Beirut**  
 Phone: +961 (0)1 / 240 430  
 Fax: +961 (0)1 / 240 438

**AFRICAN REPRESENTATIVE**

**SOUTH AFRICA**  
 CBI Ltd.  
 Private Bag 2016  
**ZA-1600 Isando**  
 Phone: +27 (0)11 / 928 2000  
 Fax: +27 (0)11 / 392 2354