

# **MELSEC A/Q Series**

Programmable Logic Controllers

User's Manual

## **CC-Link System Digital-Analog Converter Module AJ65SBT-62DA**

# • SAFETY PRECAUTIONS •

(Always read these precautions before using this equipment.)

Before using this product, please read this manual and the relevant manuals introduced in this manual carefully and pay full attention to safety to handle the product correctly.

The precautions given in this manual are concerned with this product. Refer to the user's manual of the CPU module to use for a description of the PLC system safety precautions.

In this manual, the safety instructions are ranked as "DANGER" and "CAUTION".



Indicates that incorrect handling may cause hazardous conditions, resulting in death or severe injury.

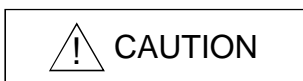

Indicates that incorrect handling may cause hazardous conditions, resulting in medium or slight personal injury or physical damage.

Note that the  CAUTION level may lead to a serious consequence according to the circumstances. Always follow the precautions of both levels because they are important to personal safety.

Please save this manual to make it accessible when required and always forward it to the end user.

## [Design Precautions]

### DANGER

- Configure a safety circuit so that the safety of the overall system is maintained even when an external power error or PLC error occurs.

Accident may occur due to output error or malfunctioning.

- (1) The status of analog output changes depending on the setting of various functions that control the analog output. Take sufficient caution when setting for those functions.

For details of analog output status, refer to Section 3.4.1 "Combinations of functions in each part"

- (2) Normal output may not be obtained due to malfunctions of output elements or the internal circuits.

Configure a circuit to monitor signals which may lead to a serious accident.

### CAUTION

- Do not bunch the control wires or communication cables with the main circuit or power wires, or install them close to each other.

They should be installed 100mm (3.9inch) or more from each other.

Not doing so could result in noise that would cause erroneous operation.

## [Installation Precautions]

### CAUTION

- Use the PLC in the environment that meets the general specifications contained in this Manual. Using the PLC outside the range of the general specifications may result in electric shock, fire or malfunction, or may damage or degrade the module.
- Securely fix the module to a DIN rail or with mounting screws, and securely tighten the mounting screws within the specified torque range.  
Undertightening can cause a drop or malfunction.  
Overtightening can cause a drop or malfunction due to damage of the screws or module.
- Do not touch the conducted area or electric parts of the module.  
Doing so may cause module malfunction or breakdowns.

## [Wiring Precautions]

### CAUTION

- Always switch power off externally in all phases before starting installation, wiring and other works.  
Not doing so can cause the product to be damaged or malfunction.
- Always earth the FG terminal to the protective earth conductor.  
Not doing so can cause a malfunction.
- Wire the module correctly after confirming the rated voltage and terminal layout of the product.  
Not doing so can cause a fire or failure.
- Tighten the terminal screws within the specified torque range.  
Undertightening can cause a short circuit or malfunction.  
Overtightening can cause a short circuit or malfunction due to damage of the screws or module.
- Ensure that no foreign matter such as chips and wire-offcuts enter the module.  
Foreign matter can cause a fire, failure or malfunction.

## [Wiring Precautions]

### CAUTION

- When connecting the communication and power supply cables to the module, always run them in conduits or clamp them.  
Not doing so can damage the module and cables due to loose, moved or accidentally pulled cables or can cause a malfunction due to a cable connection fault.
- When disconnecting the communication and power supply cables from the module, do not hold and pull the cable part.  
Disconnect the cables after loosening the screws in the portions connected to the module.  
Pulling the cables connected to the module can damage the module and cables or can cause a malfunction due to a cable connection fault.

## [Starting and Maintenance Precautions]

### CAUTION

- Do not touch the terminals while the power is on. Doing so may cause malfunction.
- Always start cleaning or terminal screw retightening after switching power off externally in all phases.  
Not doing so can cause the module to fail or malfunction.  
Undertightening can cause a drop, short circuit or malfunction.  
Overtightening can cause a drop, short circuit or malfunction due to damage of the screws or module.
- Never disassemble or modify the module.  
This may cause breakdowns, malfunction, injury and/or fire.
- Do not drop the module or give it hard impact since its case is made of resin. Doing so can damage the module.
- Mount or dismount the module to or from an enclosure after switching power off externally in all phases.  
Not doing so can cause the module to fail or malfunction.

## [Disposal Precautions]

### CAUTION

- When disposing of this product, treat it as industrial waste.

REVISIONS

\* The manual number is given on the bottom left of the back cover.

Print Date	* Manual Number	Revision
Oct., 2000	SH (NA) 080107-A	First printing

Japanese Manual Version SH-080088-A

This manual confers no industrial property rights or any rights of any other kind, nor does it confer any patent licenses. Mitsubishi Electric Corporation cannot be held responsible for any problems involving industrial property rights which may occur as a result of using the contents noted in this manual.

## INTRODUCTION

Thank you for choosing the Mitsubishi MELSEC-A series general-purpose programmable controller.  
Before using the product, please read this manual carefully to use it to its optimum.

## CONTENTS

SAFETY PRECAUTIONS .....	A- 1
REVISIONS .....	A- 4
About Manuals .....	A- 7
Conformation to the EMC Directive and Low Voltage Instruction .....	A- 7
About the Generic Terms and Abbreviations .....	A- 8
Product Components .....	A- 9
<b>1. OVERVIEW</b> .....	<b>1- 1 to 1- 2</b>
1.1 Features .....	1- 1
<b>2. SYSTEM CONFIGURATION</b> .....	<b>2- 1 to 2- 2</b>
2.1 Overall Configuration .....	2- 1
2.2 Applicable System .....	2- 2
<b>3 SPECIFICATION</b> .....	<b>3- 1 to 3- 16</b>
3.1 General Specification .....	3- 1
3.2 Performance Specification .....	3- 2
3.3 I/O Conversion Characteristics .....	3- 3
3.3.1 Voltage output characteristics .....	3- 4
3.3.2 Current output characteristics .....	3- 5
3.3.3 Relationship between offset/gain setting and analog output value .....	3- 6
3.3.4 Accuracy .....	3- 6
3.3.5 Conversion speed .....	3- 7
3.4 Function .....	3- 8
3.4.1 Combinations of various functions .....	3- 9
3.5 Remote I/O Signals .....	3- 10
3.5.1 Remote I/O signal list .....	3- 10
3.5.2 Functions of the remote I/O signals .....	3- 11
3.6 Remote Register .....	3- 13
3.6.1 Allocation of the remote register .....	3- 13
3.6.2 CH. <input type="checkbox"/> digital value setting (Addresses RWwm, RWwm+1) .....	3- 14
3.6.3 Analog output enable/disable setting (Address RWwm+2) .....	3- 14
3.6.4 Output range/HOLD/CLEAR setting (Address RWwm+3) .....	3- 15
3.6.5 CH. <input type="checkbox"/> check code (Addresses RWrn, RWrn+1) .....	3- 16
3.6.6 Error code (Address RWrn+2) .....	3- 16
<b>4 SETUP AND PREPARATION BEFORE OPERATION</b> .....	<b>4- 1 to 4- 10</b>
4.1 Pre-Operation Procedure .....	4- 1

4.2 Precautions When Handling .....	4- 1
4.3 Name of Each Part.....	4- 3
4.4 Offset/Gain Setting.....	4- 5
4.5 Section Number Setting.....	4- 7
4.6 Facing Direction of the Module Installation .....	4- 7
4.7 Data Link Cable Wiring .....	4- 8
4.7.1 Instructions for handling the CC-Link dedicated cables.....	4- 8
4.7.2 Connection of the CC-Link dedicated cables .....	4- 8
4.8 Wiring.....	4- 8
4.8.1 Wiring precautions.....	4- 8
4.8.2 Wiring of module with external equipment .....	4- 9
4.9 Maintenance and Inspection.....	4- 9

<b>5 PROGRAMMING</b>	<b>5- 1 to 5- 20</b>
----------------------	----------------------

5.1 Programming Procedure.....	5- 1
5.2 Program Examples .....	5- 2
5.2.1 Program examples for use of the ACPU/QCPU (A mode) (FROM/TO instructions).....	5- 2
5.2.2 Program examples for use of the ACPU/QCPU (A mode) (dedicated instructions).....	5- 7
5.2.3 Program examples for use of the QnACPU .....	5- 12
5.2.4 Program examples for use of the QCPU (Q mode).....	5- 16

<b>6 TROUBLESHOOTING</b>	<b>6- 1 to 6- 6</b>
--------------------------	---------------------

6.1 Error Code List .....	6- 1
6.2 Using the LED Indications to Check Errors.....	6- 2
6.3 Troubleshooting for the Case where the “ERR.” LED of the Master Station Flickers .....	6- 4

<b>APPENDIX</b>	<b>Appendix- 1 to Appendix- 4</b>
-----------------	-----------------------------------

Appendix1 Comparison between This Product and Conventional Product.....	Appendix- 1
Appendix2 External dimension diagram.....	Appendix- 3

## About Manuals

The following manuals are also related to this product.  
In necessary, order them by quoting the details in the tables below.

### **Related Manuals**

Manual Name	Manual Number (Model Code)
CC-Link System Master/Local Module User's Manual type AJ61BT11/A1SJ61BT11 Describes the system configuration, performance specifications, functions, handling, wiring and troubleshooting of the AJ61BT11 and A1SJ61BT11. (Optionally available)	IB-66721 (13J872)
CC-Link System Master/Local Module User's Manual type AJ61QBT11/A1SJ61QBT11 Describes the system configuration, performance specifications, functions, handling, wiring and troubleshooting of the AJ61QBT11 and A1SJ61QBT11. (Optionally available)	IB-66722 (13J873)
CC-Link System Master/Local Module User's Manual type QJ61BT11 Describes the system configuration, performance specifications, functions, handling, wiring and troubleshooting of the QJ61BT11. (Optionally available)	IB-080016 (13JL91)
type AnSHCPU/AnACPU/AnUCPU/QCPU-A (A mode) Programming Manual (Dedicated Instructions) Explains the instructions extended for the AnSHCPU/AnACPU/AnUCPU/ QCPU-A (A mode). (Optionally available)	IB-66251 (13J742)

## Conformation to the EMC Directive and Low Voltage Instruction

When complying with EMC Directives and Low-Voltage Directives by assembling a Mitsubishi PLC compatible with EMC Directive and Low-Voltage Directives into the user product, refer to Chapter 3 "EMC Directives and Low-Voltage Directives" in the User's Manual (Hardware) for the CPU module being used.

The CE logo is printed on the rating plate on the main body of the PLC that conforms to the EMC directive and low voltage instruction.



## About the Generic Terms and Abbreviations

Unless otherwise specified, the following generic terms and abbreviations are used in this manual to describe Type AJ65SBT-62DA digital-analog converter module.

Generic Term/Abbreviation	Description
GPPW	Abbreviation for the SW4D5C-GPPW-E or later GPP function software.
ACPU	Generic term for A0J2CPU, A0J2HCPU, A1CPU, A2CPU, A2CPU-S1, A3CPU, A1SCPU, A1SCPU-S1, A1SCPUC-24-R2, A1SHCPU, A1SJCPU, A1SJCPU-S3, A1SJHCPU, A1NCPUC, A2NCPUC, A2NCPUC-S1, A3NCPUC, A3MCPUC, A3HCPUC, A2SCPU, A2SCPU-S1, A2SHCPU, A2ACPU, A2ACPU-S1, A3ACPU, A2UCPU, A2UCPU-S1, A2ASCPU, A2ASCPU-S1, A2ASCPU-S30, A2USHCPU-S1, A3UCPU, A4UCPU
QnACPU	Generic term for Q2ACPU, Q2ACPU-S1, Q2ASCPU, Q2ASCPU-S1, Q2ASHCPU, Q2ASHCPU-S1, Q3ACPU, Q4ACPU, Q4ARCPU
QCPU (A mode)	Generic term for Q02CPU-A, Q02HCPU-A, Q06HCPU-A
QCPU (Q mode)	Generic term for Q02CPU, Q02HCPU, Q06HCPU, Q12HCPU, Q25HCPU
Master station	Station that controls the data link system. One master station is required for each system.
Local station	Station having a PLC CPU and the ability to communicate with the master and other local stations.
Remote I/O station	Remote station that handles bit unit data only. (Performs input and output with external devices.) (AJ65BTB1-16D, AJ65SBTB1-16D)
Remote device station	Remote station that handles bit unit and word unit data only. (Performs input and output with external devices, and analog data exchange.)
Remote station	Generic term for remote I/O station and remote device station. (Controlled by the master station)
Intelligent device station	Station that can perform transient transmission, such as the AJ65BT-R2 (including local stations).
Master module	Generic term for QJ61BT11, AJ61BT11, A1SJ61BT11, AJ61QBT11, and A1SJ61QBT11 when they are used as master stations.
SB	Link special relay (for CC-Link) Bit unit information that indicates the module operating status and data link status of the master station/local station. (Expressed as SB for convenience)
SW	Link special register (for CC-Link) 16 bit unit information that indicates the module operating status and data link status of the master station/local station. (Expressed as SW for convenience)
RX	Remote input (for CC-Link) Information entered in bit units from the remote station to the master station. (Expressed as RX for convenience)
RY	Remote output (for CC-Link) Information output in bit units from the remote station to the master station. (Expressed as RY for convenience)
RWw	Remote register (Write area for CC-Link) Information output in 16-bit units from the master station to the remote device station. (Expressed as RWw for convenience)
RWr	Remote register (Read area for CC-Link) Information entered in 16-bit units from the master station to the remote device station. (Expressed as RWr for convenience)

Product Components

This product consists of the following.

Product Name	Quantity
Type AJ65SBT-62DA digital - analog converter module	1
Type AJ65SBT-62DA digital - analog converter module user's manual (hardware)	1

# MEMO

---

---

---

---

---

---

---

---

---

---

---

---

---

---

---

---

---

---

---

---

---

---

---

---

---

## 1 OVERVIEW

This user's manual explains the specifications, handling, programming methods and others of Type AJ65SBT-62DA digital-analog converter module (hereafter abbreviated to the "AJ65SBT-62DA") which is used as a remote device station of a Control & Communication Link (hereafter abbreviated to "CC-Link") system. The AJ65SBT-62DA is a module designed to convert digital values (16-bit signed BIN data) from outside the PLC into analog values (voltages or currents).

### 1.1 Features

This section gives the features of the AJ65SBT-62DA.

**(1) High accuracy**

This module performs D/A conversion at the accuracy of  $\pm 0.4\%$  relative to the maximum value of the analog output value at the operating ambient temperature of 0 to 55°C, or at  $\pm 0.2\%$  relative to the maximum value of the analog output value at the operating ambient temperature of  $25 \pm 5^\circ\text{C}$ .

**(2) Output range selectable per channel**

You can choose the analog output range per channel to change the I/O conversion characteristics.

**(3) High resolution of  $1/\pm 4000$**

By changing the output range, you can choose and set the resolution to either  $1/4000$  or  $1/\pm 4000$  (when the -10 to +10V range or user range setting 1 is selected) to provide high-resolution analog values.

**(4) Setting of analog output hold or clear at STOP of PLC CPU**

You can specify whether to hold or clear the analog value which is being output from each channel of the unit when the PLC CPU has entered the STOP mode or the AJ65SBT-62DA has stopped D/A conversion due to error occurrence.

**(5) Smaller than the conventional D/A converter module**

This module is 60% smaller in installation area and 38% less in volume than the conventional CC-Link D/A converter module (AJ65BT-64DAV/DAI).

**(6) Up to 42 modules connectable**

You can connect up to 42 AJ65SBT-62DA modules to one master station.



## 2 SYSTEM CONFIGURATION

This chapter describes the system configuration for use of the AJ65SBT-62DA.

### 2.1 Overall Configuration

The overall configuration for use of the AJ65SBT-62DA is shown below.

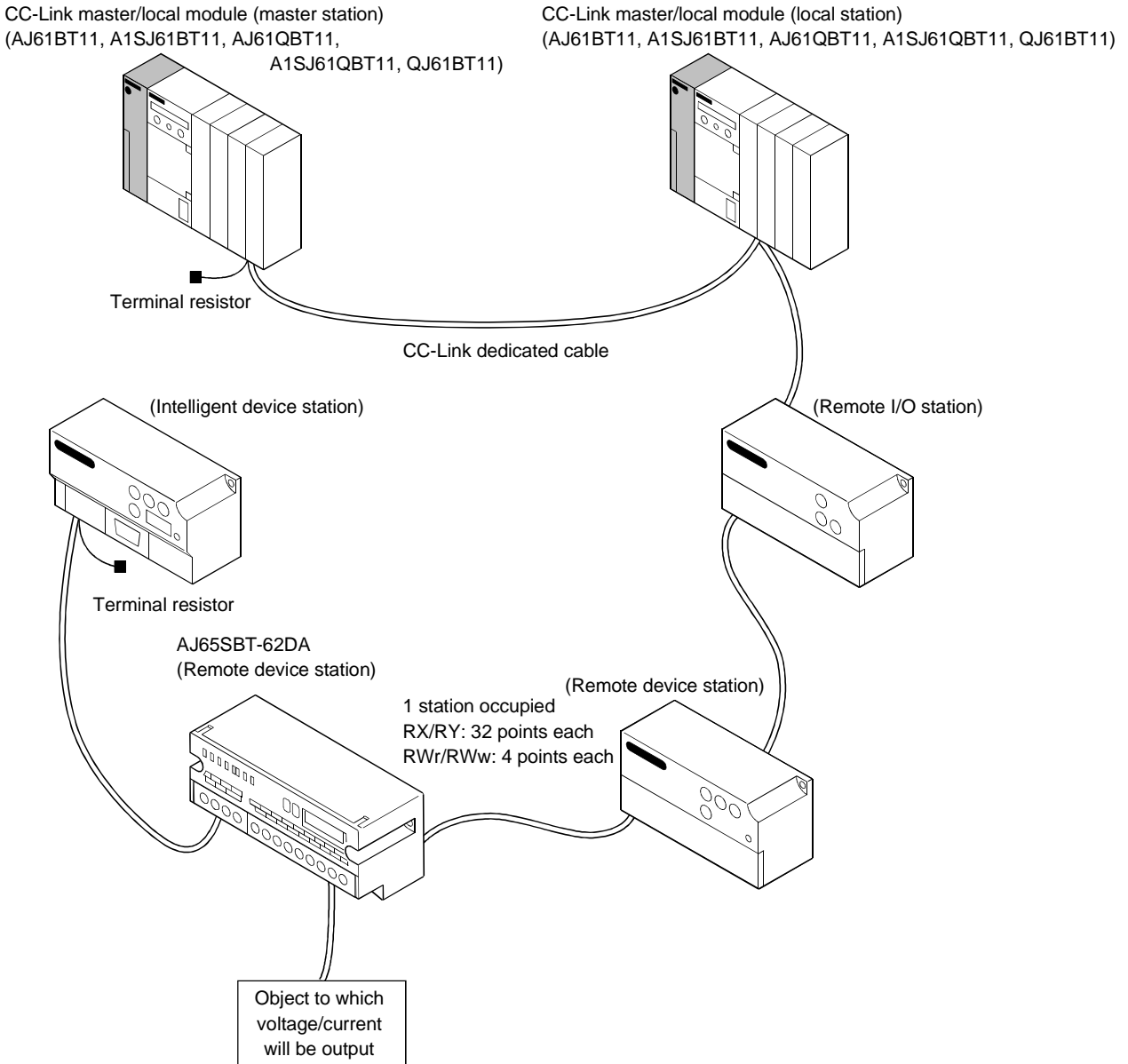

## 2.2 Applicable System

This section explains the applicable system.

### (1) Applicable master modules

The following master modules can be used with the AJ65SBT-62DA.

- AJ61BT11
- A1SJ61BT11
- AJ61QBT11
- A1SJ61QBT11
- QJ61BT11

### (2) Restrictions on use of CC-Link dedicated instructions

The CC-Link dedicated instructions may not be used depending on the PLC CPU or master module used

For details of the restrictions, refer to the A series master module user's manual.

## 3 SPECIFICATION

This chapter provides the specifications of the AJ65SBT-62DA.

## 3.1 General Specification

Table 3.1 indicates the general specifications of the AJ65SBT-62DA.

Table 3.1 General specification

Item	Specification					
Usage ambient temperature	0 to 55°C					
Storage ambient temperature	-20 to 75°C					
Usage ambient humidity	10 to 90%RH, no condensation					
Storage ambient humidity	10 to 90%RH, no condensation					
Vibration durability	Conforming to JIS B 3501, IEC 1131-2	When there is intermittent vibration				
		Frequency	Acceleration	Amplitude	Sweep count 10 times in each direction X, Y, Z (80 minutes)	
		10 to 57Hz	—	0.075mm (0.0030inch)		
		57 to 150Hz	9.8m/s <sup>2</sup>	—		
		When there is continuous vibration				
		Frequency	Acceleration	Amplitude		
		10 to 57Hz	—	0.035mm (0.0013inch)		
		57 to 150Hz	4.9m/s <sup>2</sup>	—		
Shock durability	Conforming to JIS B 3501, IEC1131-2 (147m/s <sup>2</sup> , 3 times each in 3 directions)					
Usage environment	No corrosive gas					
Usage height	Less than 2000 m (less than 6562 ft.)					
Installation area	Within the control board					
Over-voltage category *1	Less than II					
Pollution level *2	Less than 2					

\*1 Indicates the location where the device is connected from the public cable network to the device structure wiring area.

Category II applies to the devices to which the power is supplied from a fixed equipment.

Surge withstand voltage for devices with up to 300V of rated voltage is 2500V.

\*2 This is an index which indicates the degree of conductive object generation in the environment Pollution level 2 is when only non-conductive pollution occurs.

A temporary conductivity caused by condensation must be expected occasionally.



## 3.2 Performance Specification

Table 3.2 indicates the performance specifications of the AJ65SBT-62DA.

Table 3.2 Performance Specifications

Item		AJ65SBT-62DA					
Digital input	Voltage	16-bit signed binary (-4096 to +4095)					
	Current	16-bit signed binary (0 to 4095)					
Analog output	Voltage	-10 to +10VDC (external load resistance: 2k $\Omega$ to 1M $\Omega$ )					
	Current	0 to 20mADC (external load resistance: 0 to 600 $\Omega$ )					
I/O characteristics, maximum resolution, accuracy (accuracy relative to maximum value of analog output value)	Voltage	-4000 to +4000	-10 to +10V	$\pm 0.4\%$ ( $\pm 40\text{mV}$ )	$\pm 0.2\%$ ( $\pm 20\text{mV}$ )	2.5mV	
			User range setting 1 (-10 to +10V)				
	0 to 4000	0 to 5V	$\pm 0.4\%$ ( $\pm 20\text{mV}$ )	$\pm 0.2\%$ ( $\pm 10\text{mV}$ )	1.25mV		
		1 to 5V			1.0mV		
		User range setting 2 (0 to 5V)					
	Current	0 to 4000	0 to 20mA	$\pm 0.4\%$ ( $\pm 80\mu\text{A}$ )	$\pm 0.2\%$ ( $\pm 40\mu\text{A}$ )	5 $\mu\text{A}$	
			4 to 20mA			4 $\mu\text{A}$	
			User range setting 3 (0 to 20mA)				
	Factory setting is -10 to +10V.						
	Maximum conversion speed	1ms/1 channel					
Output short-circuit protection	Yes						
Absolute maximum output	Voltage: $\pm 12\text{V}$ , Current +21mA						
Number of analog output points	2 channels/1 module						
Number of occupied stations	1 station (RX/Ry: 32 points each, RWr/RWw: 4 points each)						
Connected terminal block	7-point, 2-piece terminal block (transmission, power supply) Direct-coupled, 18-point terminal block (analog output section) (M3 screw)						
Applicable wire size	0.3 to 0.75mm <sup>2</sup>						
Applicable crimping terminal	RAV1.25-3.5 (conforming to JIS C2805)						
Module mounting screw	M4 screw $\times$ 0.7mm $\times$ 16mm or more (tightening torque range: 78 to 108N $\cdot$ cm) Can also be mounted to DIN rail						
Applicable DIN rail	TH35-7.5Fe, TH35-7.5Al (conforming to JIS-C2B12)						
24VDC internal current consumption (A)	0.16						
External power supply	DC24V (DC20.4V to DC26.4V)						
	Inrush current: 8.2A, within 2.1ms						
Noise immunity	By noise simulator of 500Vp-p noise voltage, 1 $\mu\text{s}$ noise width and 25 to 60Hz noise frequency						
Dielectric withstand voltage	500VAC for 1 minute across all power supply and communication system terminals and all analog output terminals						
Isolation system	Across communication system terminals and all analog output terminals: Photocoupler isolated Across power supply system terminals and all analog output terminals: Photocoupler isolated Across channels: Non-isolated						
Weight (kg)	0.20						
Outline dimensions (mm)	118 (W) $\times$ 50 (H) $\times$ 40 (D)						

### 3.3 I/O Conversion Characteristics

An I/O conversion characteristic indicates an inclination of a straight line which connects an offset value and a gain value at the time when a digital value set from the PLC CPU is converted into an analog value (voltage or current output).

The offset value is an analog value (voltage or current) output when the digital value set from the PLC CPU is 0.

The gain value is an analog value (voltage or current) output when the digital value set from the PLC CPU is 4000.

3.3.1 Voltage output characteristics

The voltage output characteristic graph is shown below.

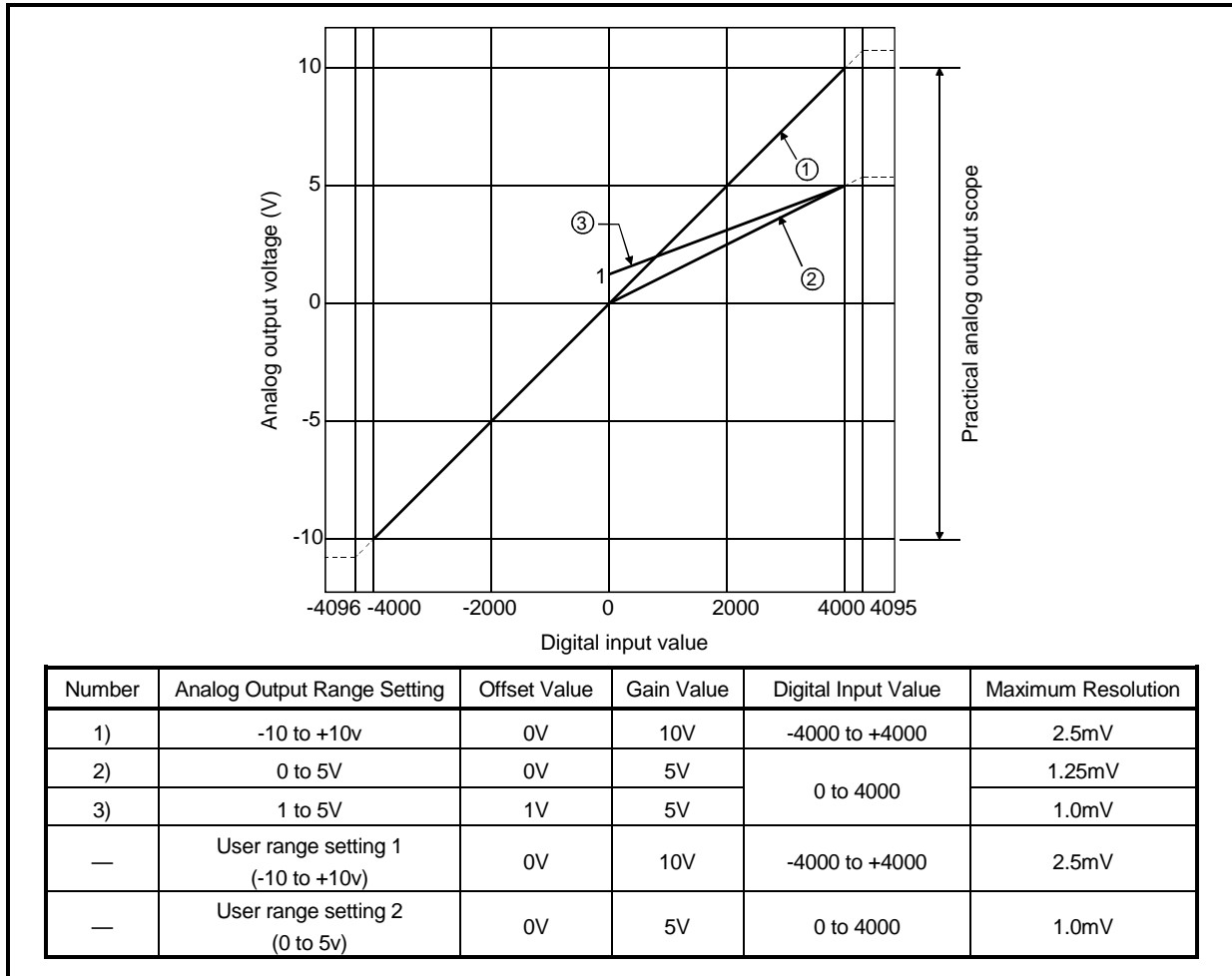

Fig. 3.1 Voltage Output Characteristic

POINT
<p>(1) Within the digital input and analog output scopes of each output range, the maximum resolution and accuracy are within the performance specification range. Outside those scopes, however, they may not fall within the performance specification range. (Avoid using the dotted line part in Fig. 3.1.)</p> <p>(2) Set the offset and gain values of the user range setting within the range satisfying the following conditions.</p> <p>(a) Setting range when user range setting 1 is selected: -10 to +10V</p> <p>(b) Setting range when user range setting 2 is selected: 0 to 5V</p> <p>(c) (Gain value) &gt; (Offset value)</p> <p>If you attempt to make setting outside the setting range of (a) or (b), the "RUN" LED flickers at 0.5s intervals. Set the values within the setting range.</p> <p>If you attempt to make setting outside the setting range of (c), the "RUN" LED flickers at 0.5s intervals. Make setting again.</p>

3.3.2 Current output characteristics

The current output characteristic graph is shown below.

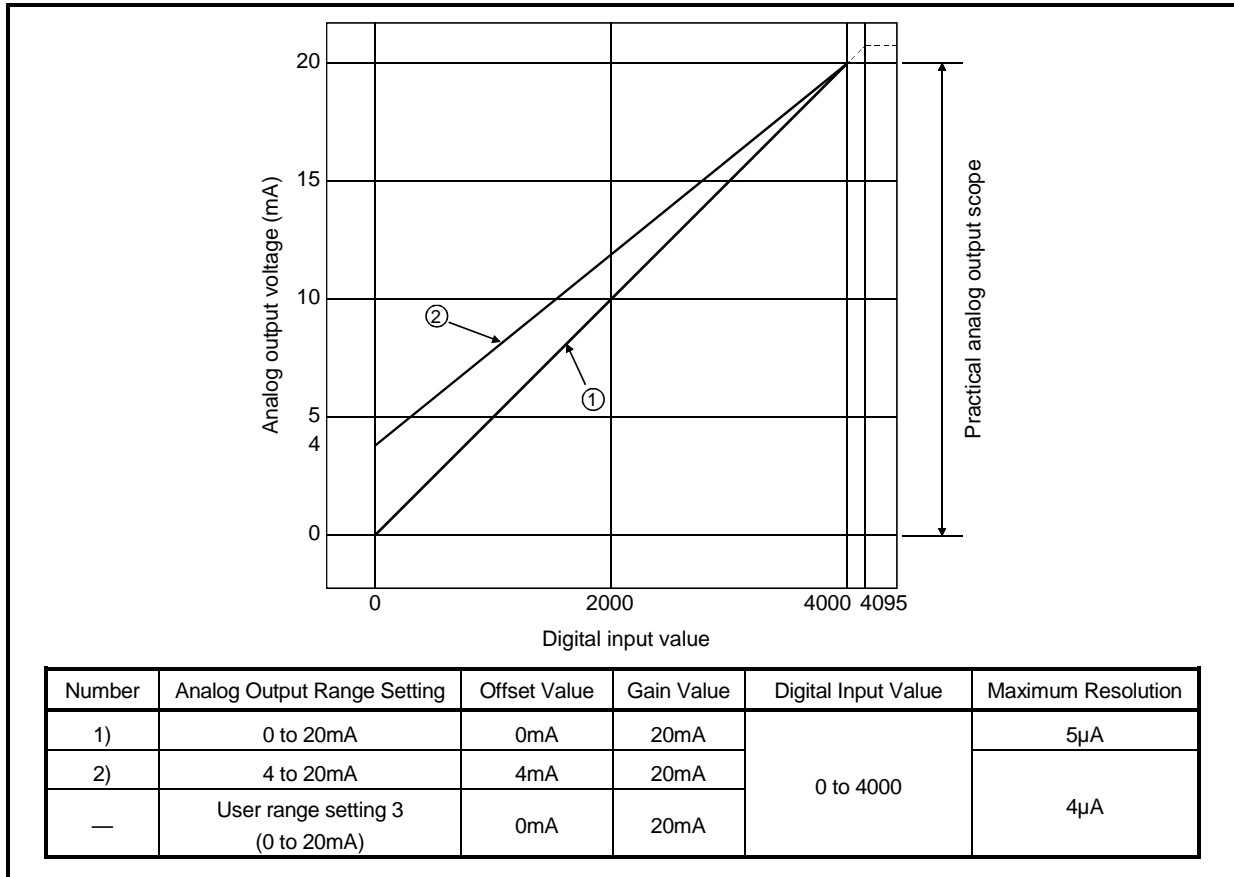

Fig. 3.2 Current Output Characteristic

POINT
<p>(1) Within the digital input and analog output scopes of each output range, the maximum resolution and accuracy are within the performance specification range. Outside those scopes, however, they may not fall within the performance specification range. (Avoid using the dotted line part in Fig. 3.2.)</p> <p>(2) Set the offset and gain values of the user range setting within the range satisfying the following conditions.</p> <p>(a) Setting range when user range setting 3 is selected: 0 to 20mA</p> <p>(b) (Gain value) &gt; (Offset value)</p> <p>If you attempt to make setting outside the setting range of (a), the "RUN" LED flickers at 0.5s intervals. Set the values within the setting range.</p> <p>If you attempt to make setting outside the setting range of (b), the "RUN" LED flickers at 0.5s intervals. Make setting again.</p>

### 3.3.3 Relationship between offset/gain setting and analog output value

How to calculate the analog output value:

The resolution of AJ65SBT-62DA can be set arbitrarily by modifying the setting of the offset value and gain value.

How to calculate the analog value resolution and the analog output value for a given digital input value when the settings of the offset value and gain value are changed is shown next.

#### (1) Resolution

Find the resolution with the following expression.

$$(\text{Analog resolution}) = \frac{(\text{Gain value}) - (\text{Offset value})}{4000}$$

#### (2) Analog output value

Find the analog output value with the following expression.

$$(\text{Analog output}) = (\text{Analog resolution}) \times (\text{Digital input value}) + (\text{Offset value})$$

### 3.3.4 Accuracy

Accuracy is relative to the maximum value of the analog output value.

If you change the offset/gain setting or output range to change the output characteristic, accuracy does not change and is held within the range indicated in the performance specifications.

#### (1) Accuracy of voltage output

For voltage output, the maximum value of the analog output value changes with the range.

For example, accuracy is relative to 5V when the 0 to 5V range is selected.

Analog output is provided at the accuracy of within  $\pm 0.2\%$  ( $\pm 10\text{mV}$ ) when the operating ambient temperature is  $25\pm 5^\circ\text{C}$ , or within  $\pm 0.4\%$  ( $\pm 20\text{mV}$ ) when the operating ambient temperature is 0 to  $55^\circ\text{C}$ .

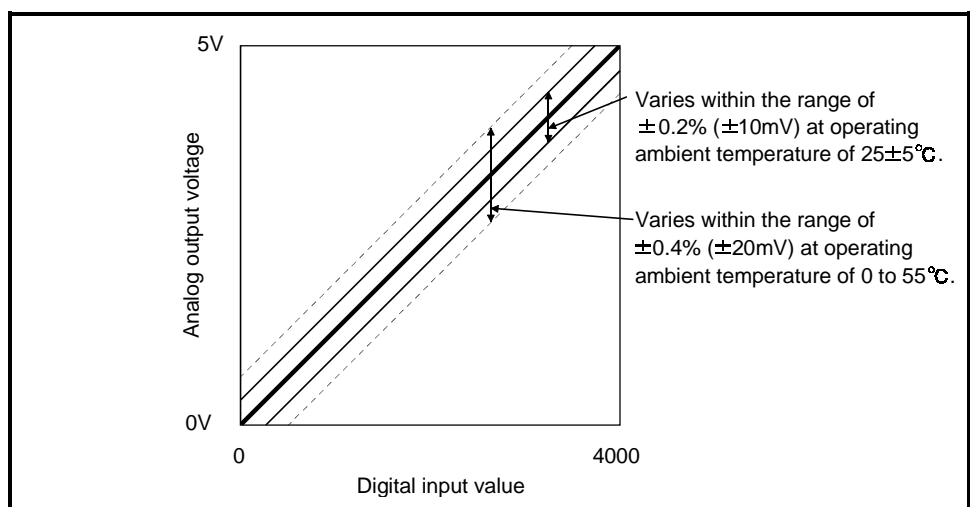

Fig. 3.3 Voltage Output Accuracy (When 0 to 5V Range Is Selected)

## (2) Accuracy of current output

For current output, accuracy is relative to 20mA.

Analog output is provided at the accuracy of within  $\pm 0.2\%$  ( $\pm 40\mu\text{A}$ ) when the operating ambient temperature is  $25\pm 5^\circ\text{C}$ , or within  $\pm 0.4\%$  ( $\pm 80\mu\text{A}$ ) when the operating ambient temperature is 0 to  $55^\circ\text{C}$ .

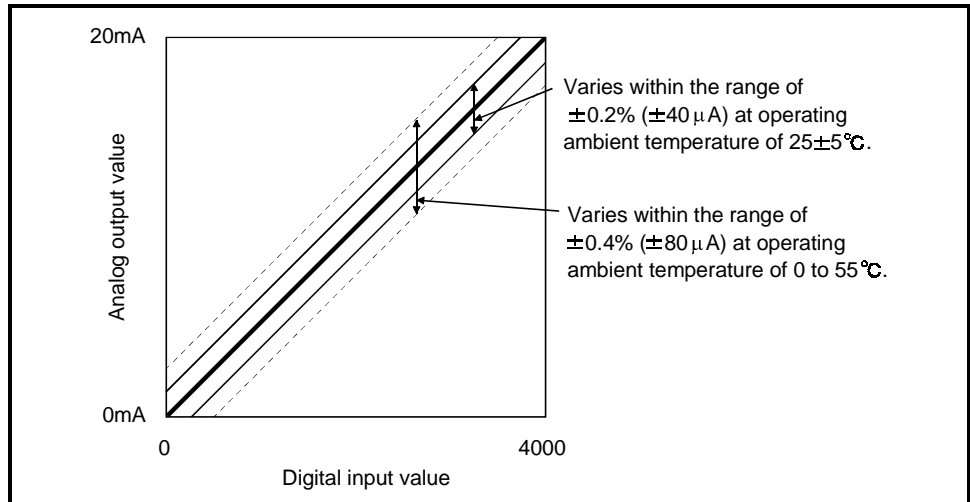

Fig. 3.4 Current Output Accuracy

## 3.3.5 Conversion speed

Conversion speed indicates time required to read the digital output value written to the buffer memory, perform D/A conversion, and then output the specified analog value.

Conversion speed per channel of the AJ65SBT-62DA is 1ms.

Due to the data link processing time of the CC-Link system, there is a transmission delay until the D/A conversion value is read actually.

For the data link processing time, refer to the user's manual of the master module used.

Example) Data link processing time taken when the master module is the AJ61BT11 or A1SJ61BT11

[Calculation expression]

$\text{SM} + \text{LS} \times 2 + \text{remote device station processing time}$

SM: Scan time of master station sequence program

LS : Link scan time

Remote device station processing time:  $(\text{Number of channels used} + 1^*) \times 1\text{ms}$

\*: Internal processing time of AJ65SBT-62DA

3.4 Function

Table 3.3 lists the functions of the AJ65SBT-62DA.

Table 3.3 AJ65SBT-62DA Function List

Item	Description	Refer to																		
D/A output enable/disable function	Specify whether the D/A conversion value is output or the offset value is output per channel. Note that the conversion speed is constant independently of the output enable/disable setting.	Section 3.5.2																		
D/A conversion enable/disable function	Specify whether D/A conversion is enabled or disabled per channel. The sampling cycle can be shortened by setting the unused channel to D/A conversion disable.	Section 3.6.3																		
Output range changing function	<p>You can set the analog output range per channel to change the I/O conversion characteristics.</p> <p>Select the output range setting from among the following 8 types.</p> <table border="1" data-bbox="453 822 1198 1133"> <thead> <tr> <th>Output Range</th> <th>Set Value</th> </tr> </thead> <tbody> <tr> <td>-10 to +10V</td> <td>0H</td> </tr> <tr> <td>0 to 5V</td> <td>1H</td> </tr> <tr> <td>1 to 5V</td> <td>2H</td> </tr> <tr> <td>0 to 20mA</td> <td>3H</td> </tr> <tr> <td>4 to 20mA</td> <td>4H</td> </tr> <tr> <td>User range setting 1 (-10 to +10V)</td> <td>5H</td> </tr> <tr> <td>User range setting 2 (0 to 5V)</td> <td>6H</td> </tr> <tr> <td>User range setting 3 (0 to 20mA)</td> <td>7H</td> </tr> </tbody> </table>	Output Range	Set Value	-10 to +10V	0H	0 to 5V	1H	1 to 5V	2H	0 to 20mA	3H	4 to 20mA	4H	User range setting 1 (-10 to +10V)	5H	User range setting 2 (0 to 5V)	6H	User range setting 3 (0 to 20mA)	7H	Section 3.6.4
Output Range	Set Value																			
-10 to +10V	0H																			
0 to 5V	1H																			
1 to 5V	2H																			
0 to 20mA	3H																			
4 to 20mA	4H																			
User range setting 1 (-10 to +10V)	5H																			
User range setting 2 (0 to 5V)	6H																			
User range setting 3 (0 to 20mA)	7H																			
Function to specify hold or clear of the analog output when the PLC CPU is in the STOP status (HOLD/CLEAR setting)	Specify per channel whether to hold or clear (output the offset value) the analog value which is being output from each channel when the PLC CPU has entered the STOP status or the AJ65SBT-62DA has stopped D/A conversion due to error occurrence.	Section 3.6.4																		
Offset/gain setting	You can make offset/gain setting per channel without potentiometers to change the I/O conversion characteristics freely.	Section 4.4																		

3.4.1 Combinations of various functions

You can set the analog output as indicated in Table 3.4 by combining the HOLD/CLEAR setting, CH.  analog output enable/disable flag and Analog output enable/disable setting.

Make setting according to your system application.

Table 3.4 Analog output status combination list

Setting combination Execution status	Analog output enable/disable setting	Enable (1)			Prohibit (0)
	CH. <input type="checkbox"/> analog output enable/disable flag	Enable (ON)		Prohibit (OFF)	Enable or disable
	HOLD/CLEAR setting	HOLD	CLEAR	HOLD or CLEAR	HOLD or CLEAR
Analog output status when the PLC CPU is in the RUN status		Output of the analog value after D/A conversion from the digital value specified by the PLC CPU		Offset value	0V/0mA
Analog output status when the PLC CPU is in the STOP status		Analog value before the PLC CPU stop is retained	Offset value	Offset value	0V/0mA
Analog output status at PLC CPU stop error		Analog value before the PLC CPU stop is retained	Offset value	Offset value	0V/0mA
Analog output status at occurrence of AJ65SBT-62DA digital value setting error		Output of the maximum or minimum analog value		Offset value	0V/0mA
Analog output status when the "L RUN" LED turns off/"L.ERR" LED turns on		The analog value before the "L RUN" LED turns off is retained.	Offset value	Offset value	0V/0mA
Analog output status when the "L ERR." LED flickers		Output of the analog value after D/A conversion from the digital value specified by the PLC CPU		Offset value	0V/0mA
Analog output status in initial processing completion status after power-reset		Output of the analog value after D/A conversion from the digital value specified by the PLC CPU		Offset value	0V/0mA
Analog output status at occurrence of AJ65SBT-62DA output range setting error		0V/0mA	0V/0mA	0V/0mA	0V/0mA
Analog output status at occurrence of AJ65SBT-62DA watchdog timer error		0V/0mA	0V/0mA	0V/0mA	0V/0mA



### 3.5 Remote I/O Signals

This section describes the assignment and functions of the remote I/O signals.

#### 3.5.1 Remote I/O signal list

Remote inputs (RX) mean the input signals from the AJ65SBT-62DA to the master module, and remote outputs (RY) mean the output signals from the master module to the AJ65SBT-62DA.

In communications with the master station, the AJ65SBT-62DA uses 32 points of the remote inputs (RX) and 32 points of the remote outputs (RY). Table 3.5 indicates the assignment and names of the remote I/O signals.

Table 3.5 Remote I/O Signals List

Signal Direction: AJ65SBT-62DA → Master Module		Signal Direction: Master Module → AJ65SBT-62DA	
Remote input (RX)	Name	Remote output (RY)	Name
RXn0 to RXnB	Reserved	RYn0	CH.1 analog output enable/disable flag
RXnC	E <sup>2</sup> PROM write error flag		
RXnD	Reserved		
RXnE			
RXnF	Test mode flag	RYn1	CH.2 analog output enable/disable flag
RX (n+1) 0 to RX (n+1) 7	Reserved	RYn2 to RY (n+1) 7	Reserved
RX (n+1) 8	Initial data processing request flag	RY (n+1) 8	Initial data processing complete flag
RX (n+1) 9	Initial data setting complete flag	RY (n+1) 9	Initial data setting request flag
RX (n+1) A	Error status flag	RY (n+1) A	Error reset request flag
RX (n+1) B	Remote READY	RY (n+1) B to RY (n+1) F	Reserved
RX (n+1) C to RX (n+1) F	Reserved		

#### POINT

The reserved devices given in Table 3.5 are used by the system and cannot be used by the user.

If the user has used (turned on/off) any of them, we cannot guarantee the functions of the AJ65SBT-62DA.

3.5.2 Functions of the remote I/O signals

Table 3.6 explains the functions of the remote I/O signals of the AJ65SBT-62DA.

Table 3.6 Remote I/O Signal Details (1/2)

Device No.	Signal Name	Description
RXnC	E <sup>2</sup> PROM write error flag	Turns on the number of E <sup>2</sup> PROM write times exceeds its limit (1000,000 times per channel). If this flag has turned on, this module itself has failed (hardware fault) and therefore this flag cannot be reset (turned off) by the error reset request flag.
RXnF	Test mode flag	Turns on in the test mode. (Used for interlock to prevent wrong output during offset/gain setting.)
RX (n+1) 8	Initial data processing request flag	<p>After power-on, the initial data processing request flag is turned on by the AJ65SBT-62DA to request the initial data to be set. Also, after the initial data processing is complete (initial data processing complete flag RY (n+1) 8 ON), the flag is turned off.</p> <p>← : Performed by sequence ladder ◄ : Performed by AJ65SBT-62DA</p>
RX (n+1) 9	Initial data setting complete flag	When the initial data setting request (RY (n+1) 9 ON) is made, the flag turns on after the initial data setting completion is done. Also, after the initial data setting is complete, the initial setting complete flag turns off when the initial data setting request flag turns off.
RX (n+1) A	Error status flag	<p>Turns on at occurrence of the output range setting error, digital value setting error or E<sup>2</sup>PROM write error (RXnC). Does not turn on at occurrence of the watchdog timer error. (The "RUN" LED goes off.)</p> <p>← : Performed by sequence ladder ◄ : Performed by AJ65SBT-62DA</p>
RX (n+1) B	Remote READY	Turns on when initial data setting is completed after power-on or at termination of the test mode. (Used for interlocking read/write from/to the master module.)

n: Address allocated to the master module by station number setting.

Table 3.6 Remote I/O Signal Details (2/2)

Device No.	Signal Name	Description
RYn0 to RYn1	CH. <input type="checkbox"/> analog output enable/disable flag	D/A conversion value output enable flag for channel 1 or 2. Turn on this flag to enable the D/A conversion value of the corresponding channel to be output. Turn off when you want to disable the output of the D/A conversion value. Processed on the leading edge of ON/OFF.
RY (n+1) 8	Initial data processing complete flag	Turns on after initial data processing completion when initial data processing is requested after power-on or test mode operation.
RY (n+1) 9	Initial data setting request flag	Turns on at the time of initial data setting or changing.
RY (n+1) A	Error reset request flag	Turning on this flag resets (turns off) the error status flag (RX(n+1)A) and also clears (to 0000H) the error code (RWm+2) and CH. <input type="checkbox"/> check code (RWm, RWm+1) in the remote register. However, since the E <sup>2</sup> PROM write error flag (RXnC) cannot be reset, the error status flag remains on, too.

n: Address allocated to the master module by station number setting.

### 3.6 Remote Register

The AJ65SBT-62DA has a remote register for data communication with the master module. The remote register allocation and data structures are described below.

#### 3.6.1 Allocation of the remote register

The allocation of the remote register is shown in Table 3.7.

Table 3.7 Allocation of the remote register

Transfer Direction	Address	Description	Default Value	Refer to
Master → Remote	RWwm	CH. 1 digital value setting	0	Section 3.6.2
	RWwm+1	CH. 2 digital value setting	0	
	RWwm+2	Analog output enable/disable setting	0	Section 3.6.3
	RWwm+3	Output range/HOLD/CLEAR setting	0	Section 3.6.4
Remote → Master	RWrn	CH. 1 check code	0	Section 3.6.5
	RWrn+1	CH. 2 check code	0	
	RWrn+2	Error code	0	Section 3.6.6
	RWrn+3	Reserved	0	—

m, n: The address set for the master station in the station number setting.

#### POINT

Do not execute read or write to the remote register that is not allowed to use. When a read or write is executed, the functions of the AJ65SBT-62DA is not guaranteed.

3.6.2 CH.  digital value setting (Addresses RWwm, RWwm+1)

- (1) This area is used to write the digital value for the D/A conversion from the PLC CPU.
- (2) The digital value at all channels become "0" in the following conditions:
  - (a) After the power is turned on, when the remote READY (RX(n+1)B) is turned on.
- (3) The digital value that may be set is a 16-bit signed binary within the setting range which matches the output range setting.  
 If a value beyond the range of the digital value resolution is set, the data in Table 3.8 is applied for the D/A conversion.  
 In addition, the checking code is stored in the check code storage area (addresses RWrn, RWrn+1).

Table 3.8 Available setting range of the digital value

Output Range	Available setting range	Digital value for the D/A conversion when the value beyond the range is set
-10 to +10V User range setting 1	-4096 to +4095 (Practical scope: -4000 to +4000)	4096 or more: 4095 -4097 or less: -4096
0 to 5V 1 to 5V User range setting 2 0 to 20mA 4 to 20mA User range setting 3	-96 to 4095 (Practical scope: 0 to 4000)	4096 or more: 4095 -97 or less: -96

3.6.3 Analog output enable/disable setting (Address RWwm+2)

- (1) Set whether D/A conversion is enabled or disabled per channel.
- (2) The default setting is conversion disable for all channels.

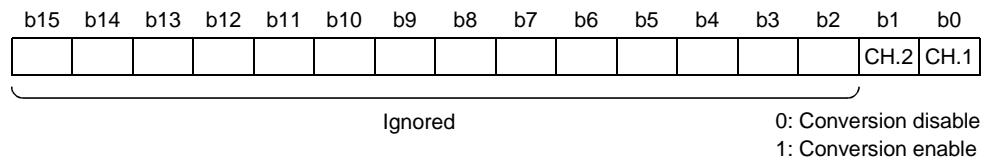

3.6.4 Output range/HOLD/CLEAR setting (Address RWwm+3)

- (1) Make output range setting using the 8 upper bits (b8 to b15) of address RWwm+3. Make HOLD/CLEAR setting using the 8 lower bits (b0 to b7) of address RWwm+3.
- (2) The default settings are -10 to +10V and CLEAR.

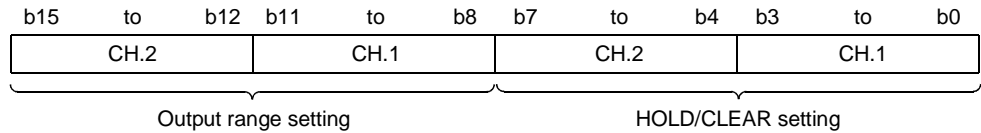

- |   |                             |
|---|-----------------------------|
| 0H: -10 to +10V<br>1H: 0 to 5V<br>2H: 1 to 5V<br>3H: 0 to 20mA<br>4H: 4 to 20mA<br>5H: User range setting 1 (-10 to +10V)<br>6H: User range setting 2 (0 to 5V)<br>7H: User range setting 3 (0 to 20mA) | 0H : CLEAR<br>1 to FH: HOLD |
|---|-----------------------------|

Example

Set 5101H when setting channel 1 to "0 to 5V" and "HOLD" and channel 2 to "User range setting 1" and "CLEAR".

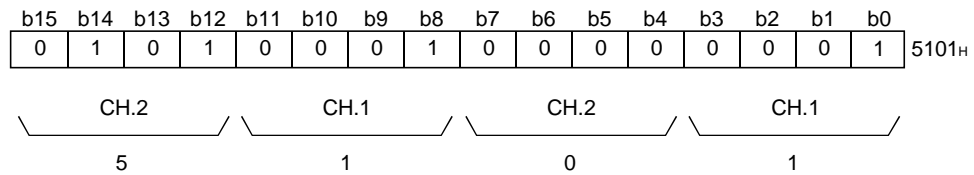

3.6.5 CH.  check code (Addresses RWrn, RWrn+1)

- (1) This area is used to check if the digital value is within or out of the setting range. One of the following checking codes is stored when the digital value lower or higher than the setting range is set.

Check code	Description
000FH	A digital value which exceeds the setting range was set.
00F0H	A digital value which is below the setting range was set.
00FFH	The digital value less than the setting range and the digital value more than the setting range were set before the error reset request.

- (2) The check code once stored is not reset even if the set value is set to within the valid setting allowed range.
- (3) The storage area or the check code is reset by turning on the error reset request flag (RY (n+1)A).

## 3.6.6 Error code (Address RWrn+2)

If an error occurs (the RUN LED flickers) when data is written to the AJ65SBT-62DA, the corresponding error code is stored into the remote register (address RWrn+2) of the AJ65SBT-62DA.

Refer to Section 6.1 for details of the error codes.

## 4 SETUP AND PREPARATION BEFORE OPERATION

## 4.1 Pre-Operation Procedure

This section explains the preparatory procedure for operating the AJ65SBT-62DA.

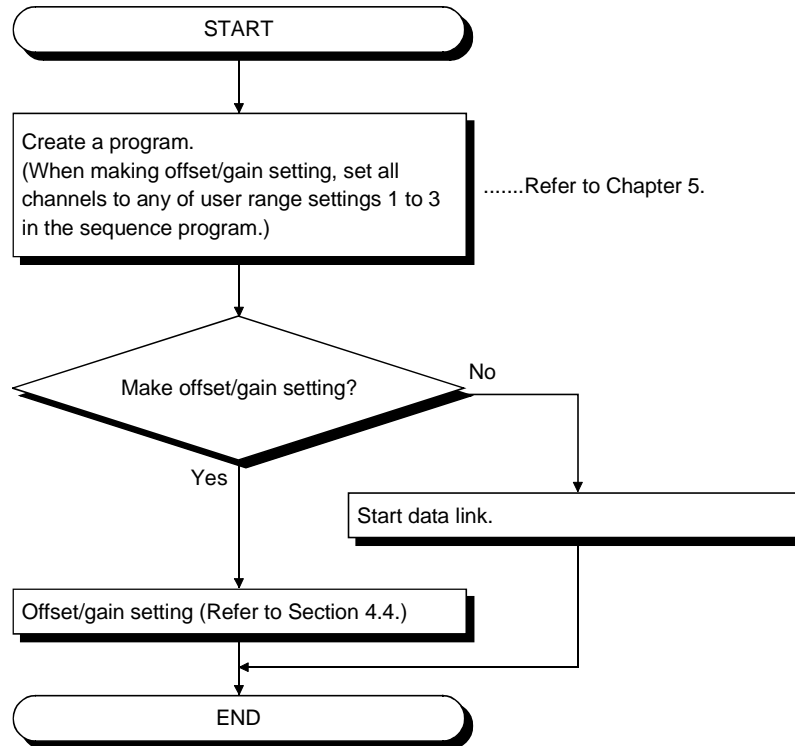

## 4.2 Precautions When Handling

The precautions when handling the AJ65SBT-62DA are described below:

**CAUTION**

- Do not touch the terminals while power is on. Doing so can cause a malfunction.
- Ensure that no foreign matter such as chips and wire-offcuts enter the module. Foreign matter can cause a fire, failure or malfunction.
- Do not disassemble or modify the module. Doing so can cause a failure, malfunction, injury or fire.
- Do not touch the conductive and electronic parts of the module directly. Doing so can cause the module to malfunction or fail.
- Do not drop the module or give it hard impact since its case is made of resin. Doing so can damage the module.
- Do not touch the conductive parts of the module directly. Doing so can cause the module to malfunction or fail.
- Tighten the terminal screws within the specified torque range. Undertightening can cause a short circuit or malfunction. Overtightening can cause a short circuit or malfunction due to damage of the screws or module.



**CAUTION**

- Dispose of the product as industrial waste.
- Use the module in the environment indicated in the general specifications given in this manual.  
Not doing so can cause an electric shock, fire, malfunction, product damage or deterioration.
- Securely fix the module to a DIN rail or with mounting screws, and securely tighten the mounting screws within the specified torque range.  
Undertightening can cause a drop or malfunction.  
Overtightening can cause a drop or malfunction due to damage of the screws or module.
- Mount or dismount the module to or from an enclosure after switching power off externally in all phases. Not doing so can cause the module to fail or malfunction.

- (1) Tighten the screws such as module installation screws and terminal screws with the following torque:

Screw location	Tightening torque range
Module installation screw (M4 screw)	78 to 108N•cm
Terminal block terminal screw (M3 screw)	59 to 88N•cm
Terminal block installation screw (M3.5 screw)	68 to 98N•cm

- (2) When using the DIN rail adapter, install the DIN rail by making sure of the following:
- (a) Applicable DIN rail models (conforming to the JIS-C2B12)
    - TH35-7.5Fe
    - TH35-7.5Al
  - (b) DIN rail installation screw interval  
When installing the DIN rail, tighten the screws with less than 200mm (7.87 inch) pitches.
- (3) When mounting the AJ65SBT-62DA to the DIN rail, press with your finger the centerline of the DIN rail hook at the bottom of the module until it clicks.

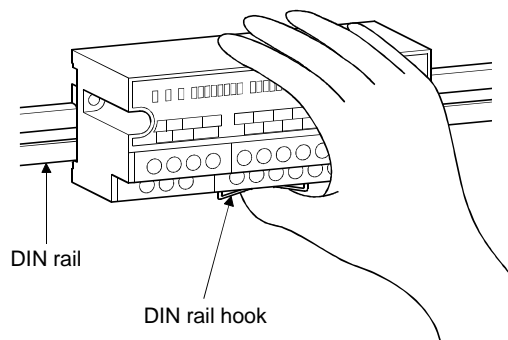

- (4) Refer to the Master Module user's manual for the name, specification, and manufacturers of supported cables for the use with AJ65SBT-62DA.

4.3 Name of Each Part

The name of each part in the AJ65SBT-62DA is shown.

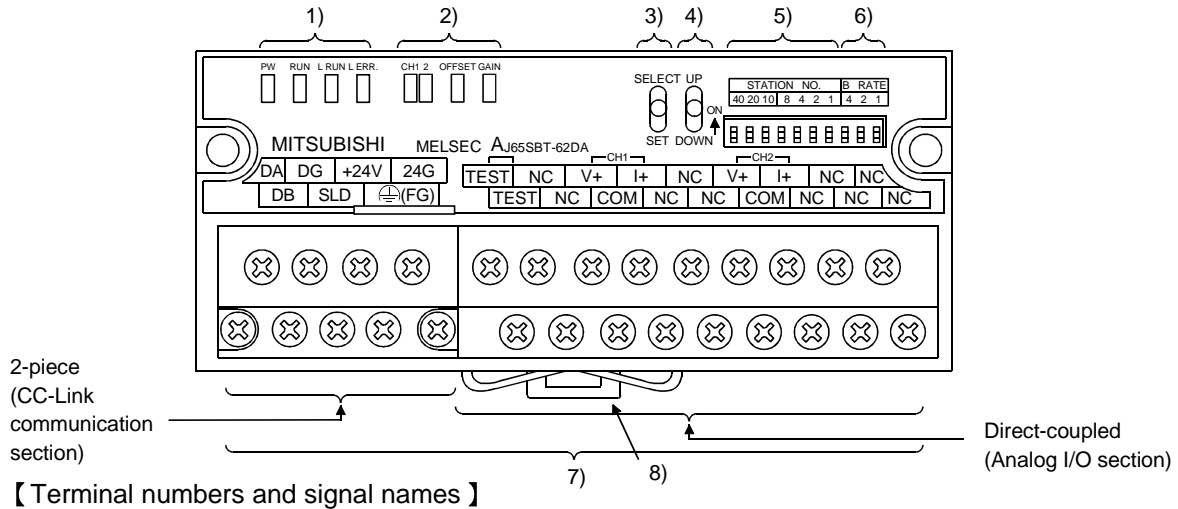

1	3	5	7	8	10	12	14	16	18	20	22	24
DA	DG	+24V	24G	TEST	NC	V+	I+	NC	V+	I+	NC	NC
2	4	6		9	11	13	15	17	19	21	23	25
DB	SLD	(FG)		TEST	NC	COM	NC	NC	COM	NC	NC	NC

Number	Name and appearance	Description		
1)	Operation status display LED	PW LED	ON: Power supply on OFF: Power supply off	
		RUN LED	Normal mode	On : Normal operation Flashing : 0.1s intervals indicate an output range setting error. 0.5s intervals indicate a digital value setting error. Off : 24VDC power supply shutoff or watchdog timer error occurred.
			Test mode	On : Indicates that the SELECT/SET switch is in the SET position. Flashing : 0.1s intervals indicate that the output range setting is not any of "user range settings 1 to 3". 0.5s intervals indicate that you attempted to make offset/gain setting outside the setting range. Off : Indicates that the SELECT/SET switch is in the SELECT or center position.
		L RUN LED	On : Normal communication Off : Communication cutoff (time expiration error)	
L ERR. LED	On : Indicates that transmission speed setting or station number setting is outside the range. Flicker at fixed intervals : Indicates that transmission speed setting or station number setting was changed from that at power-on. Flicker at unfixed intervals : Indicates that you forgot fitting the termination resistor or the module or CC-Link dedicated cable is affected by noise. Off : Indicates normal communications.			
2)	Offset/gain adjusting LEDs	CH <input type="checkbox"/>	Normal mode	Normally OFF.
		OFFSET GAIN	Test mode	The LEDs lit change every time the SELECT/SET switch is moved to SELECT. (Refer to Section 4.4.)
3)	SELECT/SET switch	Used to make offset/gain setting in the test mode.		

Number	Name and appearance	Description																																																																																																														
4)	UP/DOWN switch	Used to adjust the offset value and gain value of the channel specified by the SELECT/SET switch.																																																																																																														
5)	Station number setting switches	<p>Use the switches in STATION NO. "10", "20" and "40" to set the tens of the station number. Use the switches in STATION NO. "1", "2", "4" and "8" to set the units of the station number. The switches are all factory-set to OFF.</p> <p>Always set the station number within the range 1 to 64. You cannot set the same station number to two or more stations. Setting any other number than 1 to 64 will result in an error, flickering the "L ERR." LED.</p> <table border="1" data-bbox="512 602 1406 981"> <thead> <tr> <th rowspan="2">Station Number</th> <th colspan="3">Tens</th> <th colspan="4">Units</th> </tr> <tr> <th>40</th> <th>20</th> <th>10</th> <th>8</th> <th>4</th> <th>2</th> <th>1</th> </tr> </thead> <tbody> <tr><td>1</td><td>OFF</td><td>OFF</td><td>OFF</td><td>OFF</td><td>OFF</td><td>OFF</td><td>ON</td></tr> <tr><td>2</td><td>OFF</td><td>OFF</td><td>OFF</td><td>OFF</td><td>OFF</td><td>ON</td><td>OFF</td></tr> <tr><td>3</td><td>OFF</td><td>OFF</td><td>OFF</td><td>OFF</td><td>OFF</td><td>ON</td><td>ON</td></tr> <tr><td>4</td><td>OFF</td><td>OFF</td><td>OFF</td><td>OFF</td><td>ON</td><td>OFF</td><td>OFF</td></tr> <tr><td>:</td><td>:</td><td>:</td><td>:</td><td>:</td><td>:</td><td>:</td><td>:</td></tr> <tr><td>10</td><td>OFF</td><td>OFF</td><td>ON</td><td>OFF</td><td>OFF</td><td>OFF</td><td>OFF</td></tr> <tr><td>11</td><td>OFF</td><td>OFF</td><td>ON</td><td>OFF</td><td>OFF</td><td>OFF</td><td>ON</td></tr> <tr><td>:</td><td>:</td><td>:</td><td>:</td><td>:</td><td>:</td><td>:</td><td>:</td></tr> <tr><td>64</td><td>ON</td><td>ON</td><td>OFF</td><td>OFF</td><td>ON</td><td>OFF</td><td>OFF</td></tr> </tbody> </table> <p>(Example) To set the station number to "32", set the switches as indicated below.</p> <table border="1" data-bbox="512 1057 1406 1167"> <thead> <tr> <th rowspan="2">Station Number</th> <th colspan="3">Tens</th> <th colspan="4">Units</th> </tr> <tr> <th>40</th> <th>20</th> <th>10</th> <th>8</th> <th>4</th> <th>2</th> <th>1</th> </tr> </thead> <tbody> <tr> <td>32</td> <td>OFF</td> <td>ON</td> <td>ON</td> <td>OFF</td> <td>OFF</td> <td>ON</td> <td>OFF</td> </tr> </tbody> </table>	Station Number	Tens			Units				40	20	10	8	4	2	1	1	OFF	OFF	OFF	OFF	OFF	OFF	ON	2	OFF	OFF	OFF	OFF	OFF	ON	OFF	3	OFF	OFF	OFF	OFF	OFF	ON	ON	4	OFF	OFF	OFF	OFF	ON	OFF	OFF	:	:	:	:	:	:	:	:	10	OFF	OFF	ON	OFF	OFF	OFF	OFF	11	OFF	OFF	ON	OFF	OFF	OFF	ON	:	:	:	:	:	:	:	:	64	ON	ON	OFF	OFF	ON	OFF	OFF	Station Number	Tens			Units				40	20	10	8	4	2	1	32	OFF	ON	ON	OFF	OFF	ON	OFF
Station Number	Tens			Units																																																																																																												
	40	20	10	8	4	2	1																																																																																																									
1	OFF	OFF	OFF	OFF	OFF	OFF	ON																																																																																																									
2	OFF	OFF	OFF	OFF	OFF	ON	OFF																																																																																																									
3	OFF	OFF	OFF	OFF	OFF	ON	ON																																																																																																									
4	OFF	OFF	OFF	OFF	ON	OFF	OFF																																																																																																									
:	:	:	:	:	:	:	:																																																																																																									
10	OFF	OFF	ON	OFF	OFF	OFF	OFF																																																																																																									
11	OFF	OFF	ON	OFF	OFF	OFF	ON																																																																																																									
:	:	:	:	:	:	:	:																																																																																																									
64	ON	ON	OFF	OFF	ON	OFF	OFF																																																																																																									
Station Number	Tens			Units																																																																																																												
	40	20	10	8	4	2	1																																																																																																									
32	OFF	ON	ON	OFF	OFF	ON	OFF																																																																																																									
6)	Transmission speed setting switches	<table border="1" data-bbox="512 1234 1406 1476"> <thead> <tr> <th rowspan="2">Set Value</th> <th colspan="3">Setting Switches</th> <th rowspan="2">Transmission Speed</th> </tr> <tr> <th>4</th> <th>2</th> <th>1</th> </tr> </thead> <tbody> <tr><td>0</td><td>OFF</td><td>OFF</td><td>OFF</td><td>156kbps</td></tr> <tr><td>1</td><td>OFF</td><td>OFF</td><td>ON</td><td>625kbps</td></tr> <tr><td>2</td><td>OFF</td><td>ON</td><td>OFF</td><td>2.5Mbps</td></tr> <tr><td>3</td><td>OFF</td><td>ON</td><td>ON</td><td>5.0Mbps</td></tr> <tr><td>4</td><td>ON</td><td>OFF</td><td>OFF</td><td>10Mbps</td></tr> </tbody> </table> <p>Always set the transmission speed within the above range. The switches are all factory-set to OFF. Making any other setting than the above will result in an error, flickering the "L ERR." LED.</p>	Set Value	Setting Switches			Transmission Speed	4	2	1	0	OFF	OFF	OFF	156kbps	1	OFF	OFF	ON	625kbps	2	OFF	ON	OFF	2.5Mbps	3	OFF	ON	ON	5.0Mbps	4	ON	OFF	OFF	10Mbps																																																																													
Set Value	Setting Switches			Transmission Speed																																																																																																												
	4	2	1																																																																																																													
0	OFF	OFF	OFF	156kbps																																																																																																												
1	OFF	OFF	ON	625kbps																																																																																																												
2	OFF	ON	OFF	2.5Mbps																																																																																																												
3	OFF	ON	ON	5.0Mbps																																																																																																												
4	ON	OFF	OFF	10Mbps																																																																																																												
7)	Terminal block	Used to connect the module power supply, transmission and I/O signals.																																																																																																														
8)	DIN rail hook	Used to mount the module to the DIN rail.																																																																																																														

4.4 Offset/Gain Setting

When changing the I/O conversion characteristics, follow the procedure below.

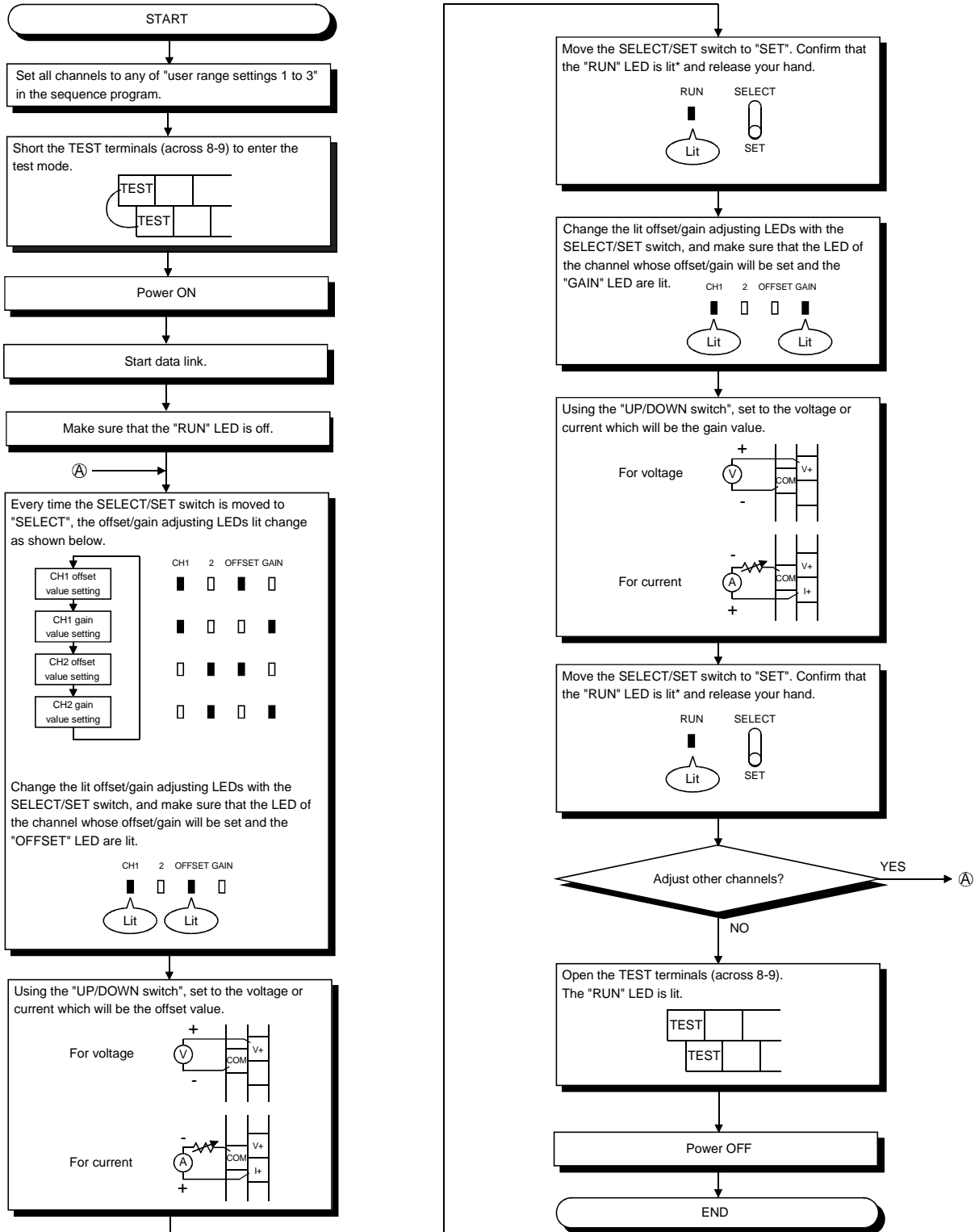

\*: If the "RUN" LED is not lit, E<sup>2</sup>PROM may have failed. For details, refer to Section 3.5.2

POINT
<p>(1) Set the offset and gain values in the actual usage state.</p> <p>(2) The offset and gain values are stored on E<sup>2</sup>PROM in the AJ65SBT-62DA and are not cleared at power-off.</p> <p>(3) Shorting the TEST terminals to enter the test mode and executing initial settings will start D/A conversion on all channels. To judge the test mode, use the test mode flag as an interlock.</p> <p>(4) Make offset/gain setting within the range indicated in POINT of Section 3.3.1 and Section 3.3.2. If setting is made outside this range, the maximum resolution/accuracy may not fall within the performance specifications range.</p> <p>(5) When making offset/gain setting (in the test mode), set all channels to any of "user range settings 1 to 3". Setting any other range will result in an error and flicker the "RUN" LED at 0.1s intervals. Refer to Section 3.6.4 for output range setting.</p>

#### 4.5 Section Number Setting

The station number setting of the AJ65SBT-62DA determines the buffer memory addresses of the master module where the remote I/O signals and read/write data are stored.

For details, refer to the user's manual of the master module used.

#### 4.6 Facing Direction of the Module Installation

The AJ65SBT-62DA module may be installed in any of six directions.

(There are no restrictions on the facing directions.)

Also, a DIN rail may be used for installation.

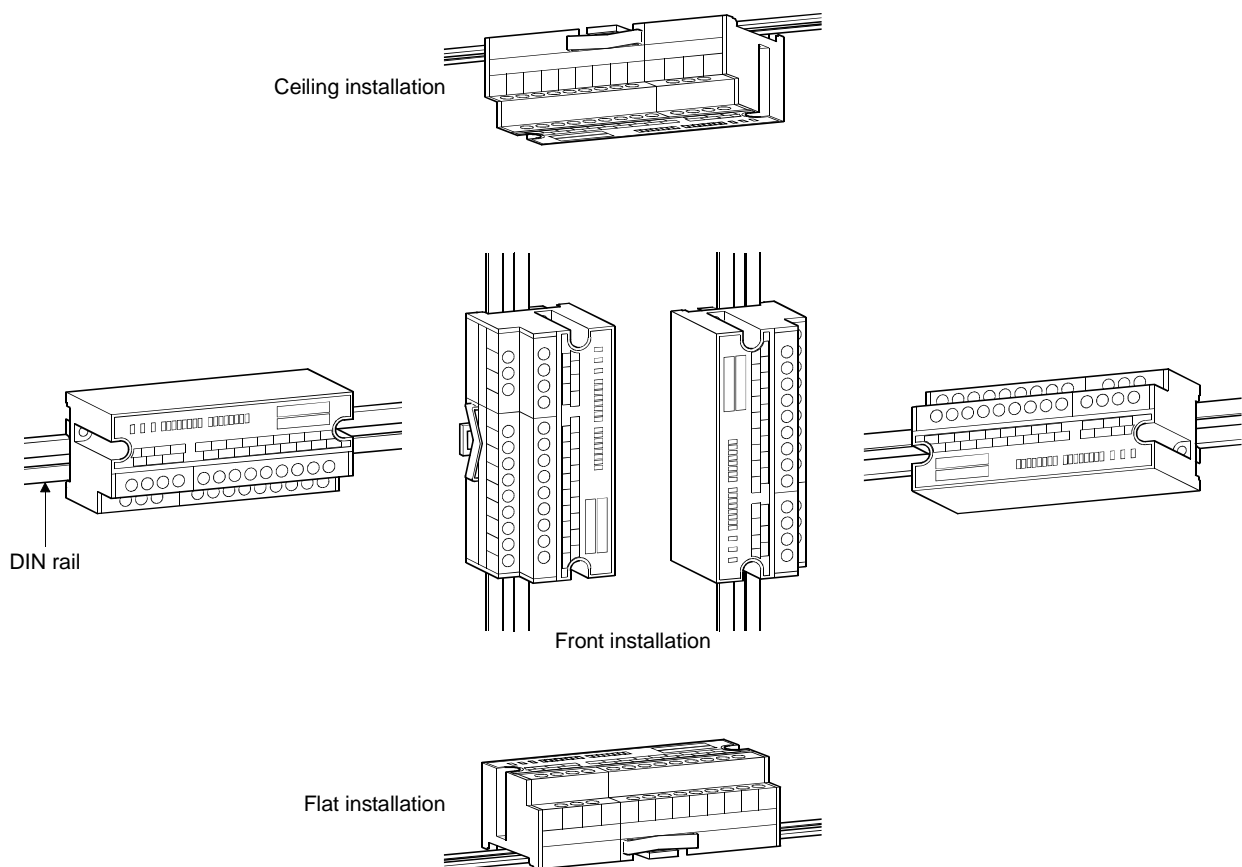

## 4.7 Data Link Cable Wiring

This section explains the wiring of the CC-Link dedicated cable used for connection of the AJ65SBT-62DA and master module.

### 4.7.1 Instructions for handling the CC-Link dedicated cables

Do not handle the CC-Link dedicated cables roughly as described below. Doing so can damage the cables.

- Compact with a sharp object.
- Twist the cable excessively.
- Pull the cable hard. (more than the permitted elasticity.)
- Step on the cable.
- Place an object on the top.
- Scratch the cable's protective layer.

### 4.7.2 Connection of the CC-Link dedicated cables

Connect the CC-Link dedicated cable between the AJ65SBT-62DA and master module as shown below.

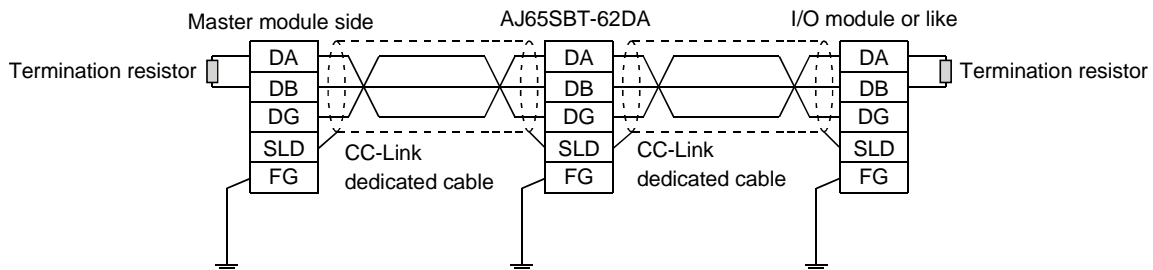

## 4.8 Wiring

This section provides the instructions for wiring the AJ65SBT-62DA and its wiring with external equipment.

### 4.8.1 Wiring precautions

To obtain maximum performance from the functions of AJ65SBT-62DA and improve the system reliability, an external wiring with high durability against noise is required. The precautions when performing external wiring are as follows:

- (1) Use separate cables for the AC and AJ65SBT-62DA external input signals, in order not to be affected by the AC side surge or conductivity.
- (2) Do not bundle or place with load carrying wires other than the main circuit line, high voltage line or PLC. Noises, surges, or conductivity may affect the system.
- (3) Place a one-point grounding on the PLC side for the shielded line or shielded cable.

4.8.2 Wiring of module with external equipment

(1) For voltage output

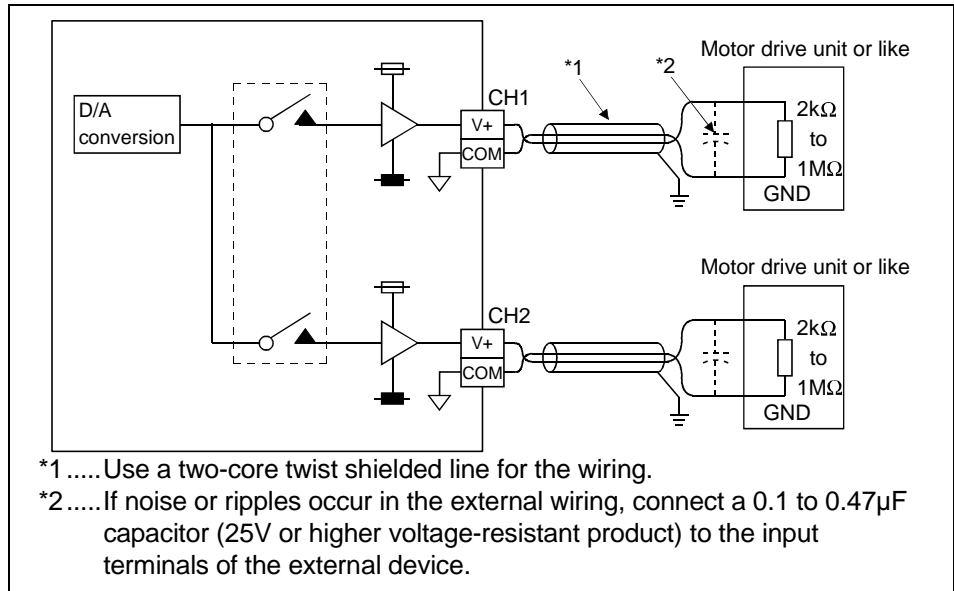

(2) For current output

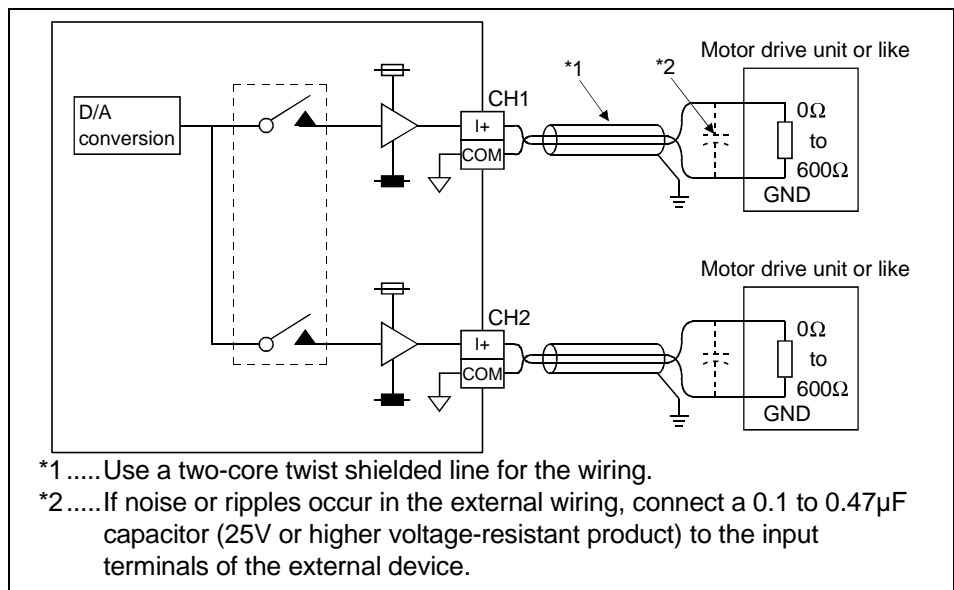

<b>POINT</b>
D/A conversion values are fluctuated by self-heating within approx. 30 minutes after power is turned ON.

4.9 Maintenance and Inspection

There are no special inspection items for the AJ65SBT-62DA module, but follow the inspections items describes in the PLC CPU User's Manual so that the system can always be used in the best condition.





## 5 PROGRAMMING

The programming procedure, basic read/write programs, and program examples for the AJ65SBT-62DA are described.

Refer to Section 3.6 for the remote registers and to the AnSHCPU/AnACPU/AnUCPU programming manual (dedicated instructions) for details of the dedicated instructions.

### 5.1 Programming Procedure

Create programs for executing the digital-analog conversion of the AJ65SBT-62DA in the following procedure.

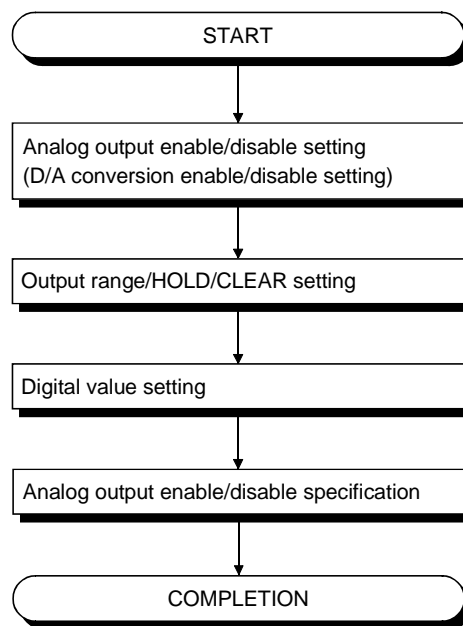

5.2 Program Examples

This section provides the program examples of the AJ65SBT-62DA.

5.2.1 Program examples for use of the ACPU/QCPU (A mode) (FROM/TO instructions)

The program examples in this section are created under the following conditions.  
Network parameter setting is made in the sequence program.

[Relationships between PLC CPU, master module and AJ65SBT-62DA]

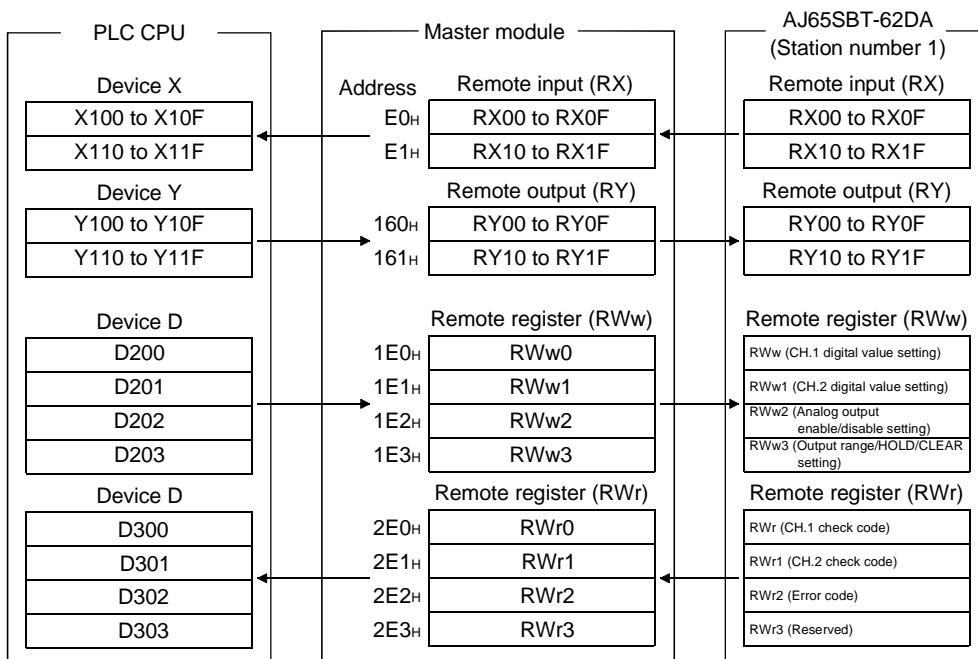

[Initial settings]

- D/A conversion enabled channels ..... Channels 1, 2
- Input range setting ..... Channel 1: 0 to 5V  
Channel 2: User range setting 1
- HOLD/CLEAR setting ..... Channel 1: HOLD  
Channel 2: CLEAR
- Digital value setting ..... Channel 1: 1000  
Channel 2: 2000
- Analog output enable channel ..... Channels 1, 2

(1) Program example for power-on

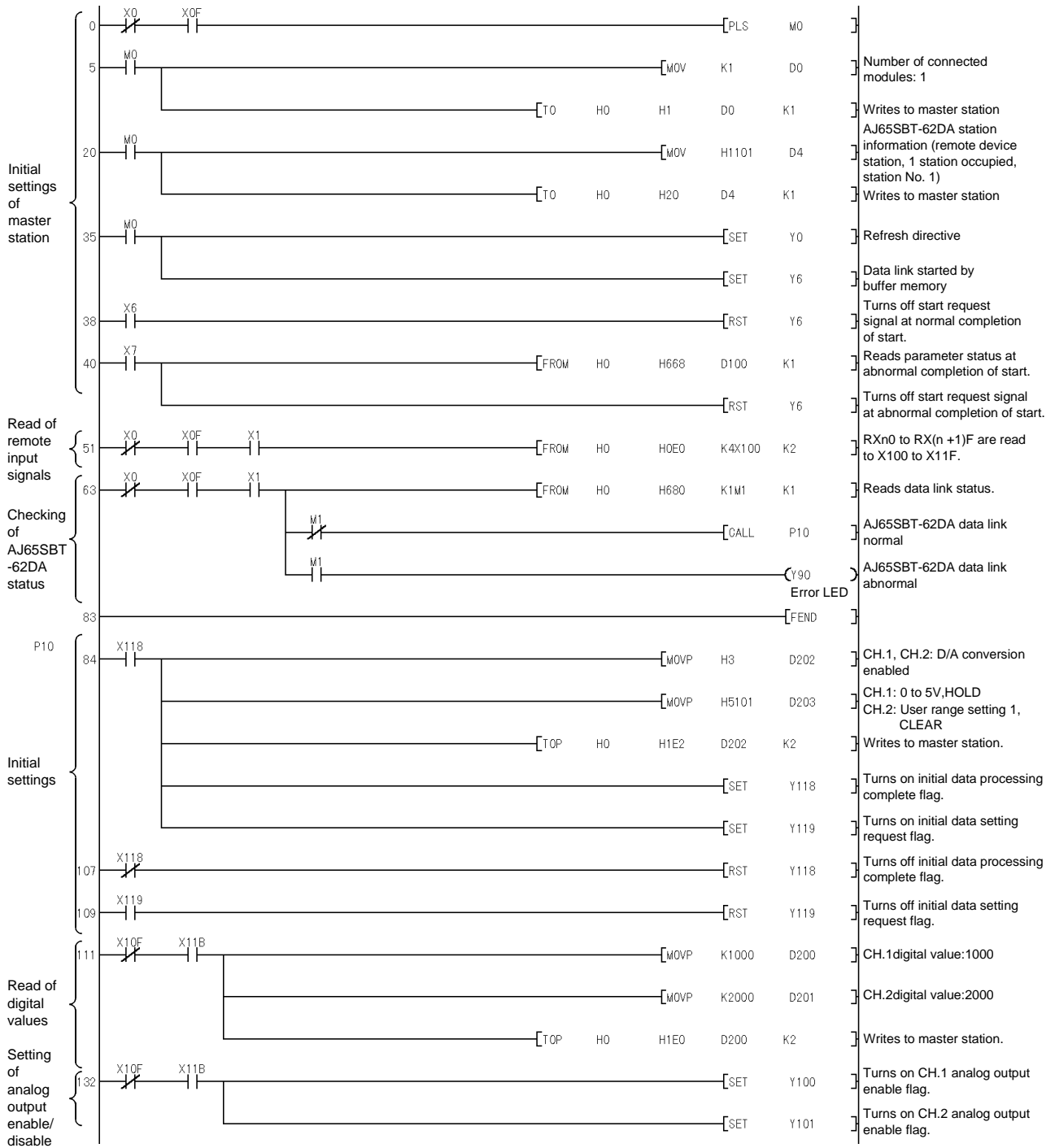

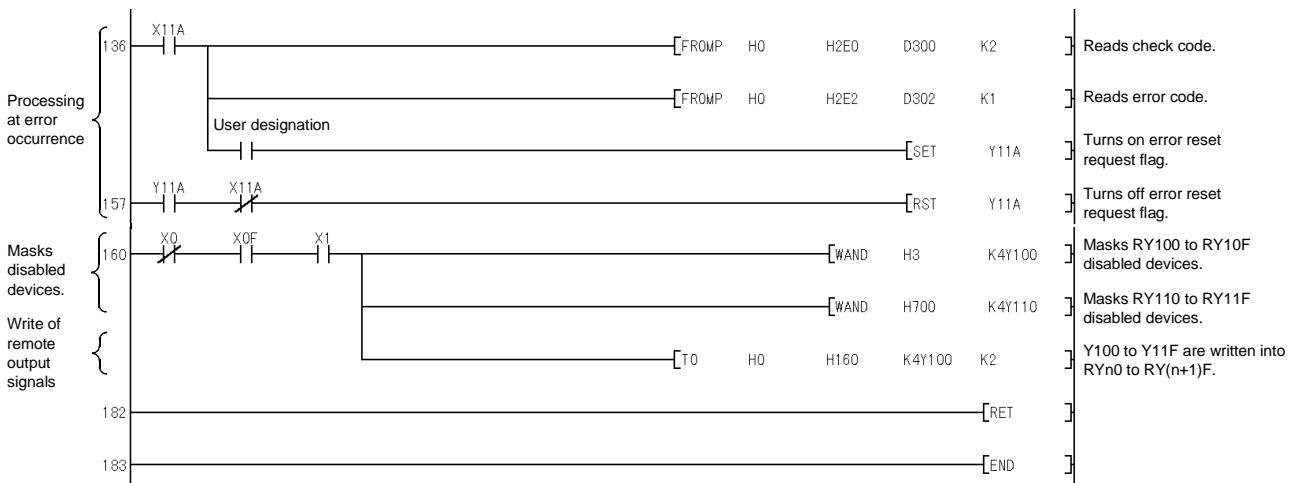

(2) Program example for initial data changing

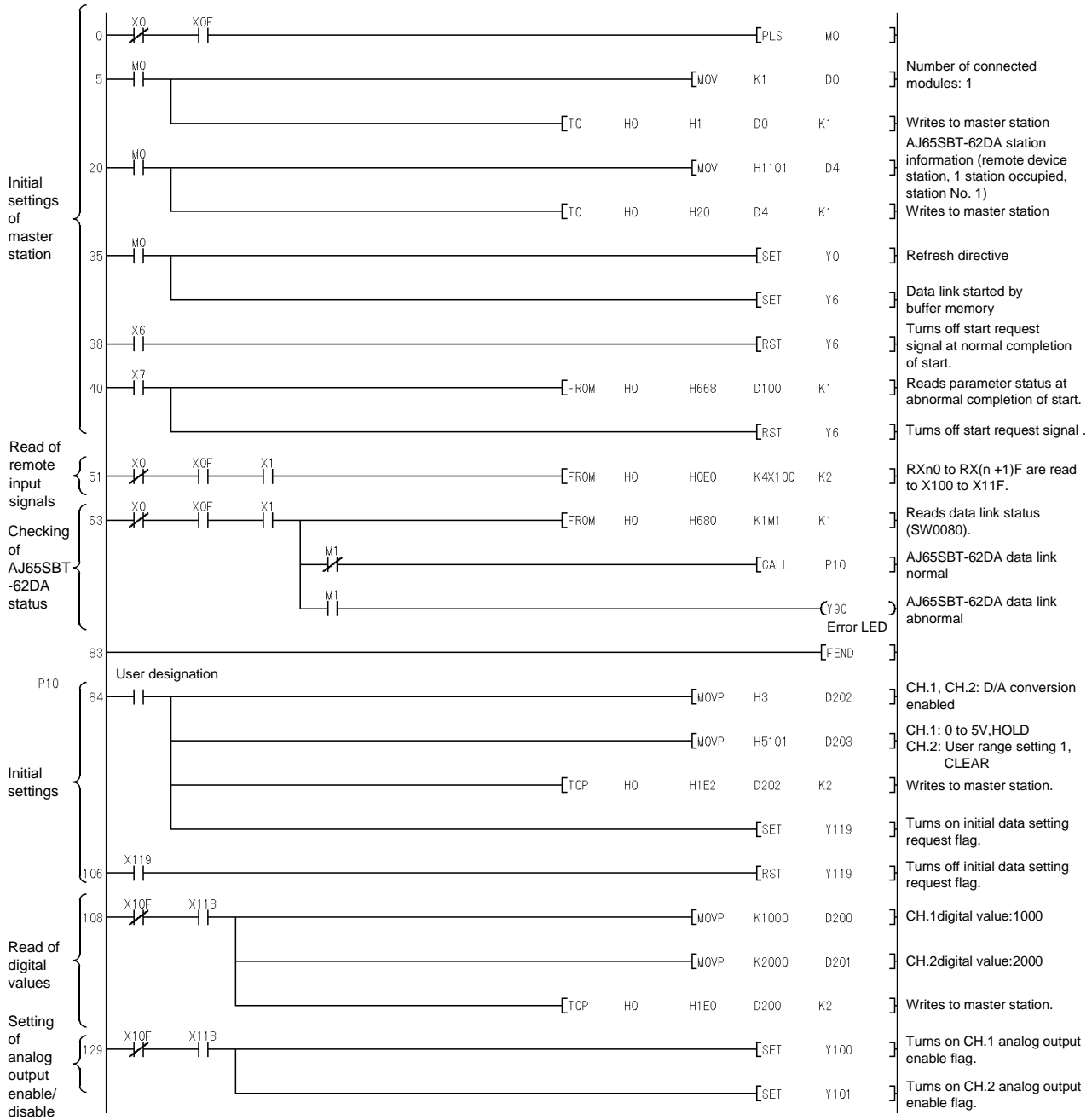

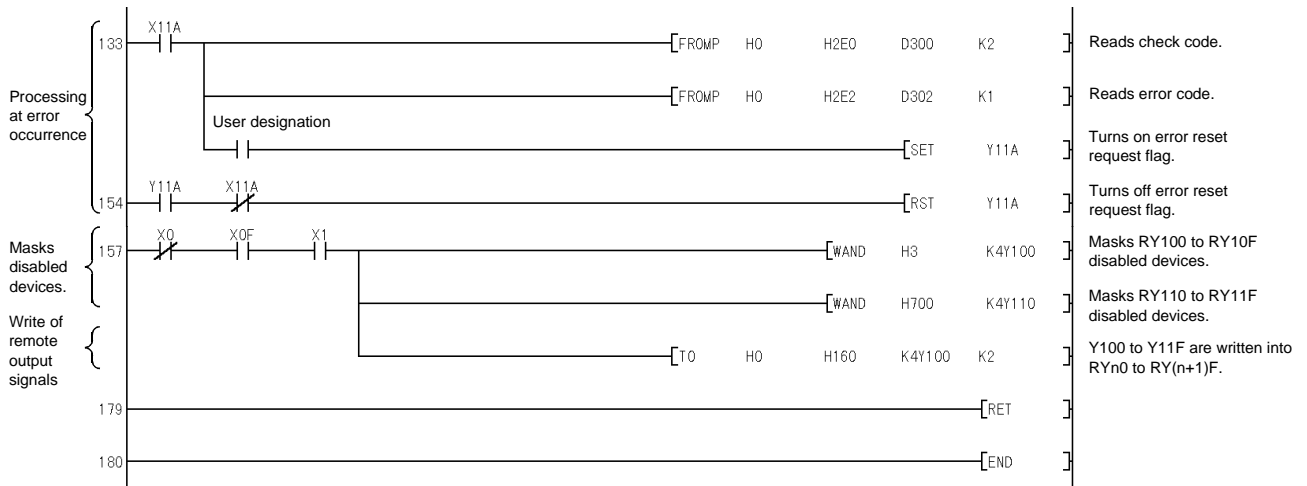

5.2.2 Program examples for use of the ACPU/QCPU (A mode) (dedicated instructions)

The program examples in this section are created under the following conditions.  
 A sequence program is used to set the network and automatic refresh parameters.

[Relationships between PLC CPU, master module and AJ65SBT-62DA]

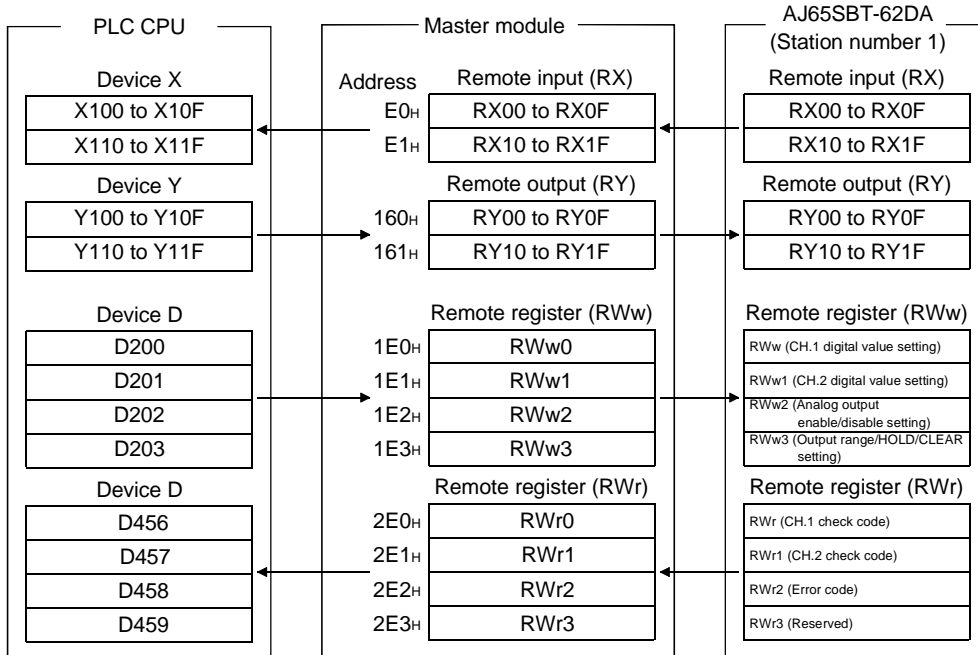

[Initial settings]

- D/A conversion enabled channels .....Channels 1, 2
- Input range setting .....Channel 1: 0 to 5V  
 Channel 2: User range setting 1
- HOLD/CLEAR setting .....Channel 1: HOLD  
 Channel 2: CLEAR
- Digital value setting .....Channel 1: 1000  
 Channel 2: 2000
- Analog output enable channel .....Channels 1, 2



(1) Program example for power-on

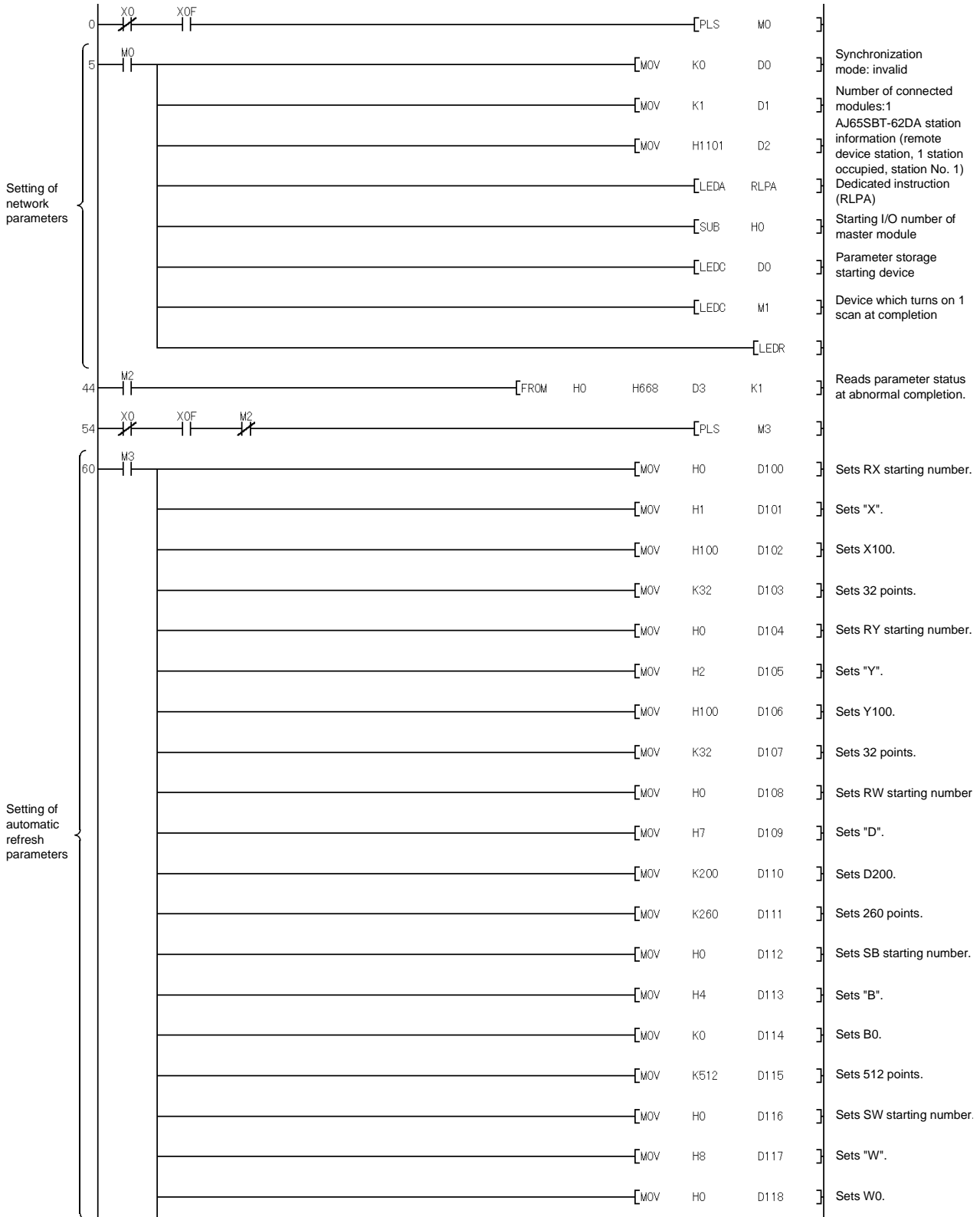

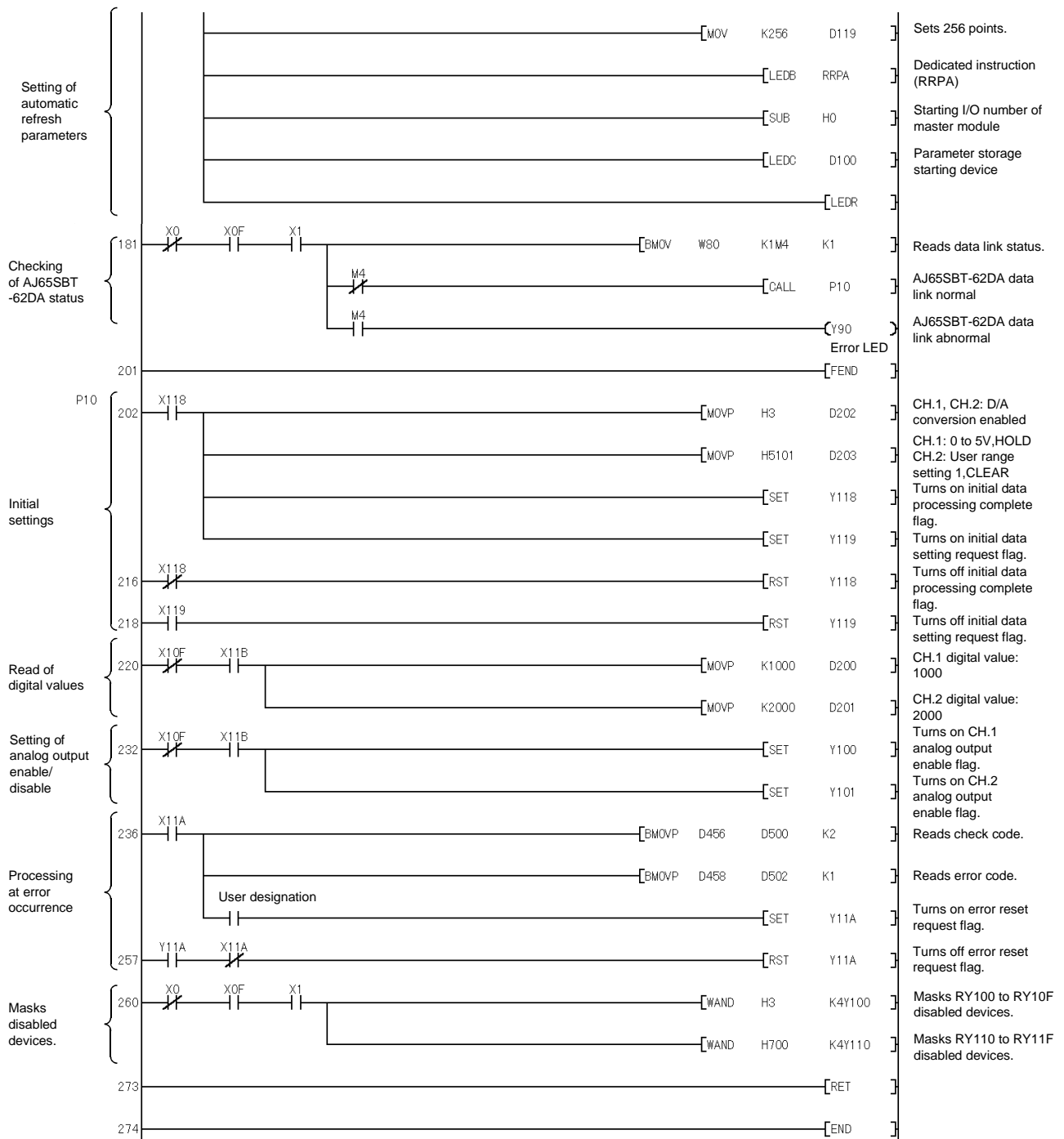

(2) Program example for initial data changing

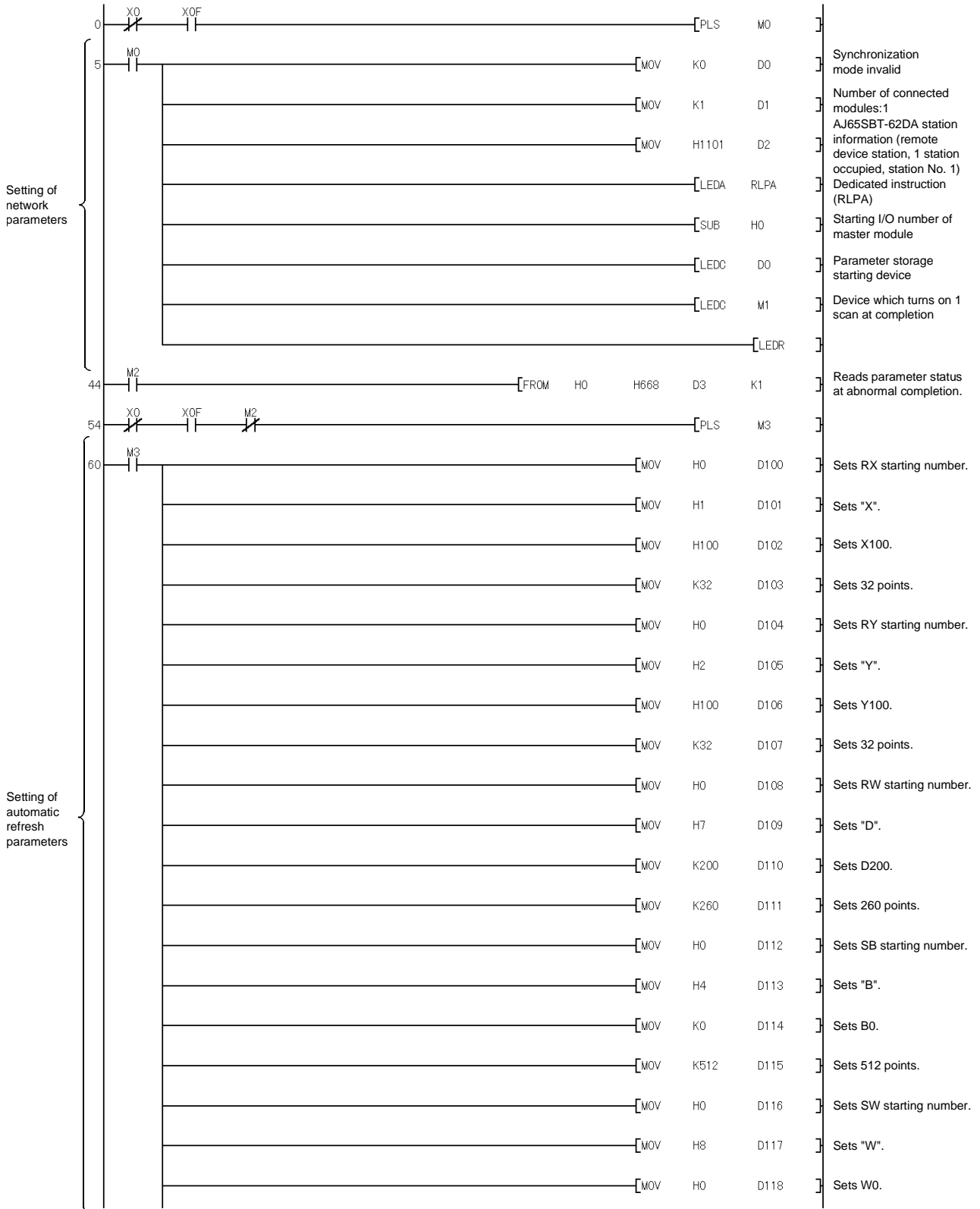

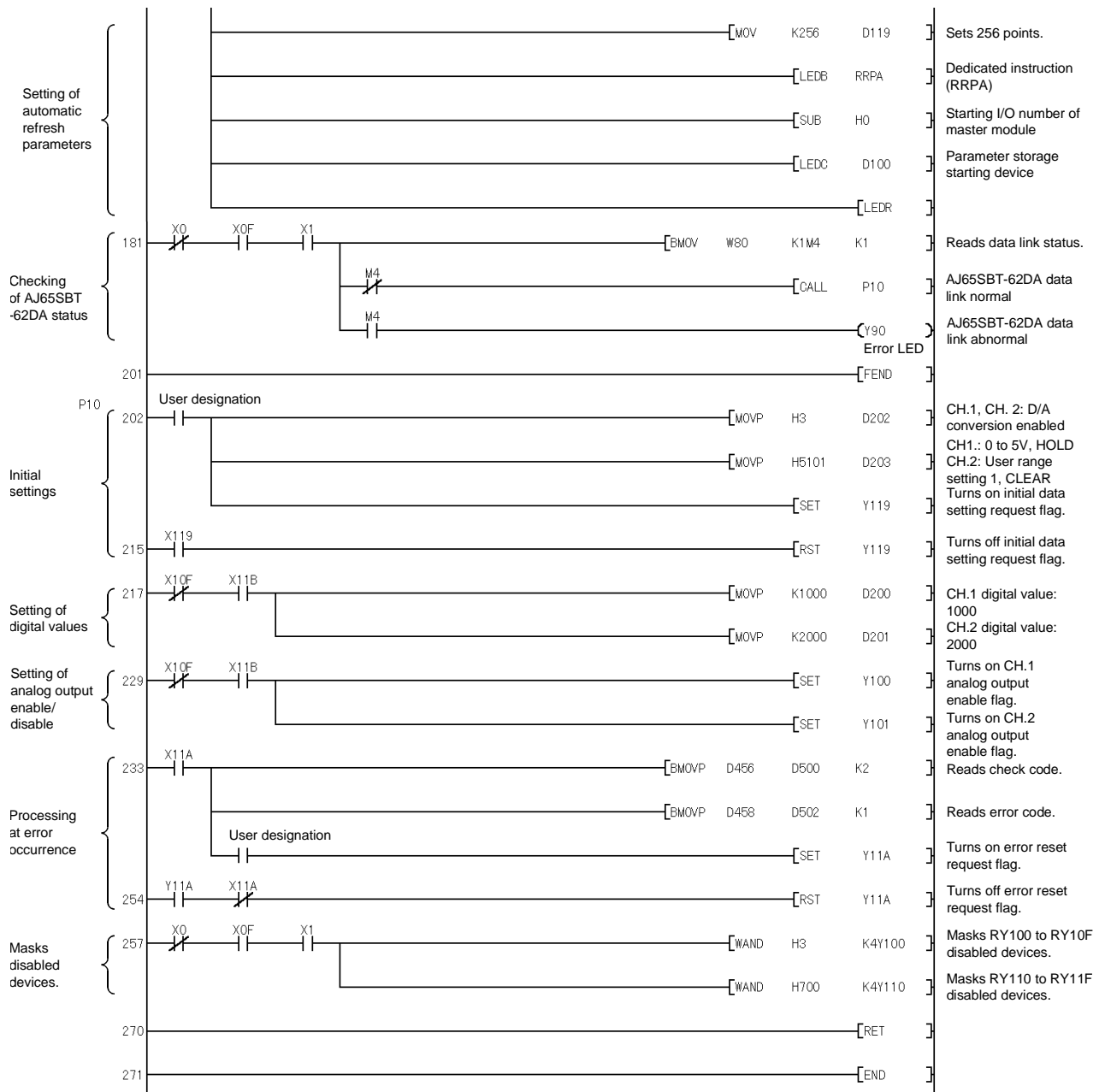

## 5.2.3 Program examples for use of the QnACPU

The program examples in this section are created under the following conditions.  
GPPW is used to set the network and automatic refresh parameters.

[Relationships between PLC CPU, master module and AJ65SBT-62DA]

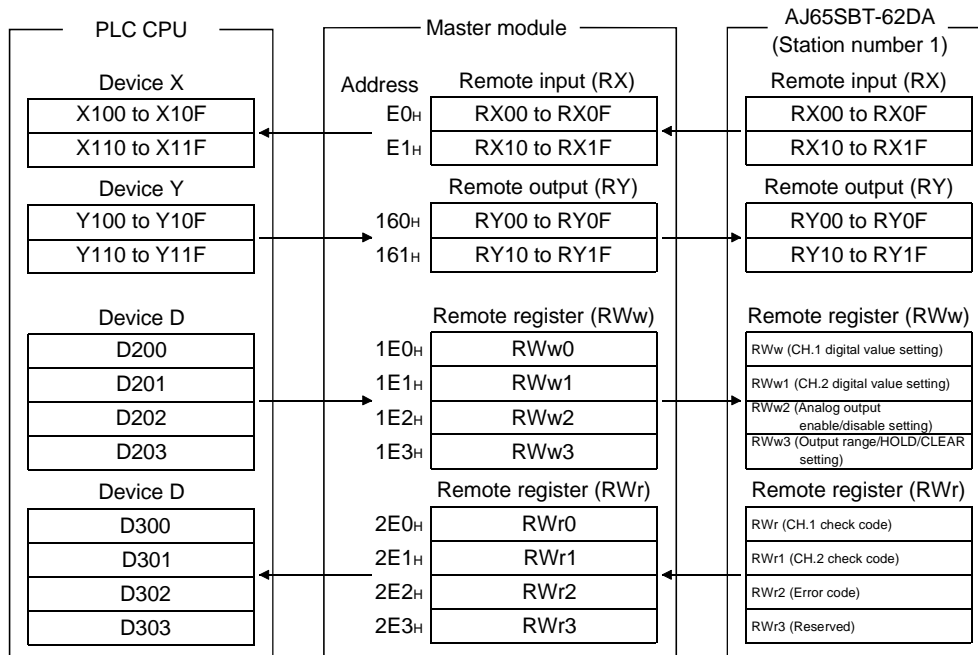

## [Initial settings]

D/A conversion enabled channels .....	Channels 1, 2
Input range setting .....	Channel 1: 0 to 5V
	Channel 2: User range setting 1
HOLD/CLEAR setting .....	Channel 1: HOLD
	Channel 2: CLEAR
Digital value setting .....	Channel 1: 1000
	Channel 2: 2000
Analog output enable channel .....	Channels 1, 2

## [Network parameter setting]

	1
Start I/O No.	0000
Type	Master station ▼
All connect count	1
Remote input(RX)	
Remote output(RY)	
Remote register(RW/r)	
Remote register(RW/w)	
Special relay(SB)	
Special register(SW)	
Retry count	3
Automatic reconnection station count	1
Wait master station No.	0
PLC down select	Stop ▼
Scan mode setting	Asynchronously ▼
Delay information setting	0
Station information setting	Station information

StationNo.	Station type	Exclusive station count	Reserve/invalid station select	Intelligent buffer select(word) ▲		
				Send	Receive	Automatic
1/1	Remote device station ▼	Exclusive station 1 ▼	No setting ▼			

## [Automatic refresh parameter setting]

	1
Start I/O No.	0000
Type	Master station ▼
All connect count	1
Remote input(RX)	X100
Remote output(RY)	Y100
Remote register(RW/r)	D300
Remote register(RW/w)	D200
Special relay(SB)	B0
Special register(SW)	W0
Retry count	3
Automatic reconnection station count	1
Wait master station No.	0
PLC down select	Stop ▼
Scan mode setting	Asynchronously ▼
Delay information setting	0
Station information setting	Station information

(1) Program example for power-on

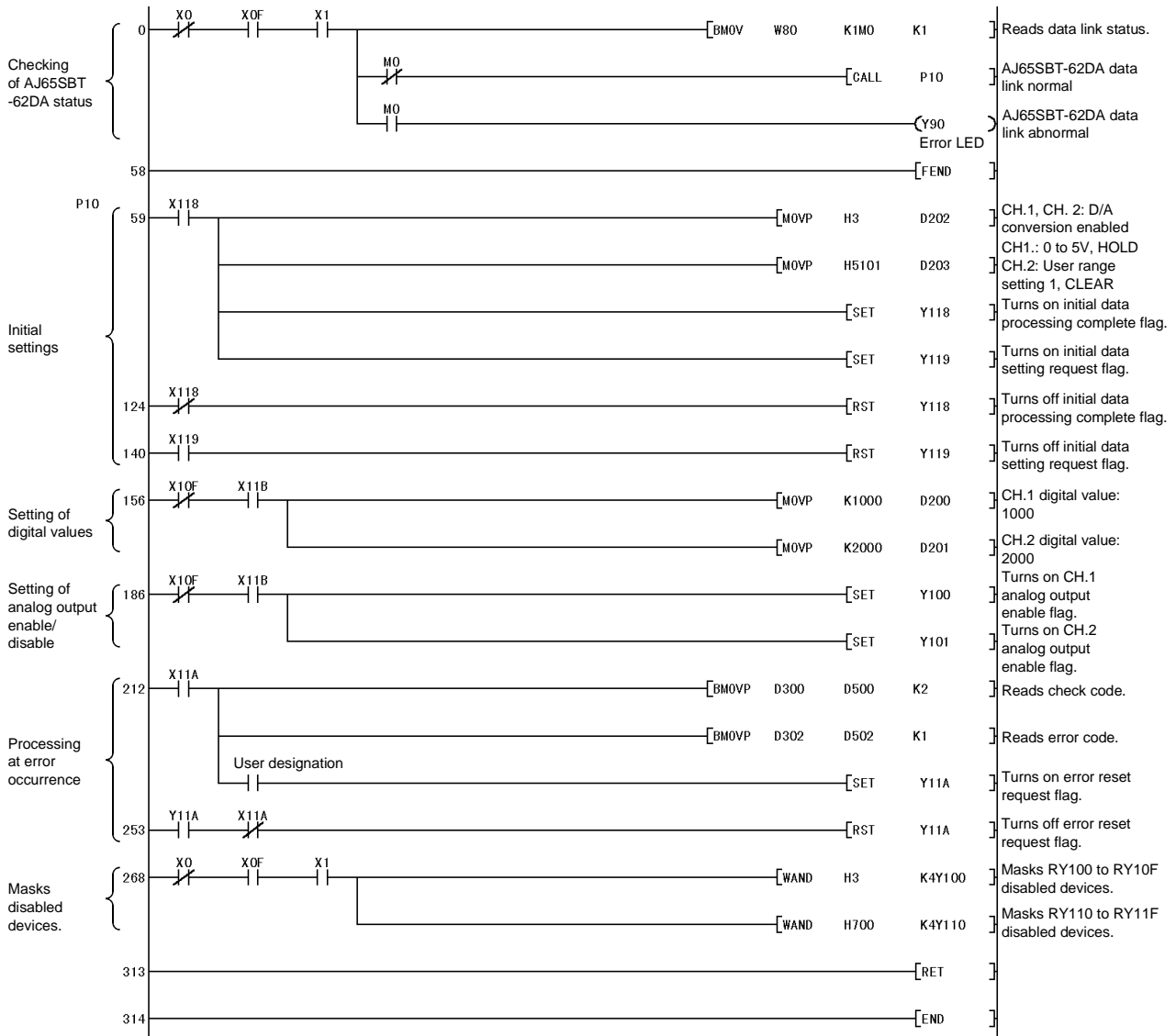

(2) Program example for initial data changing

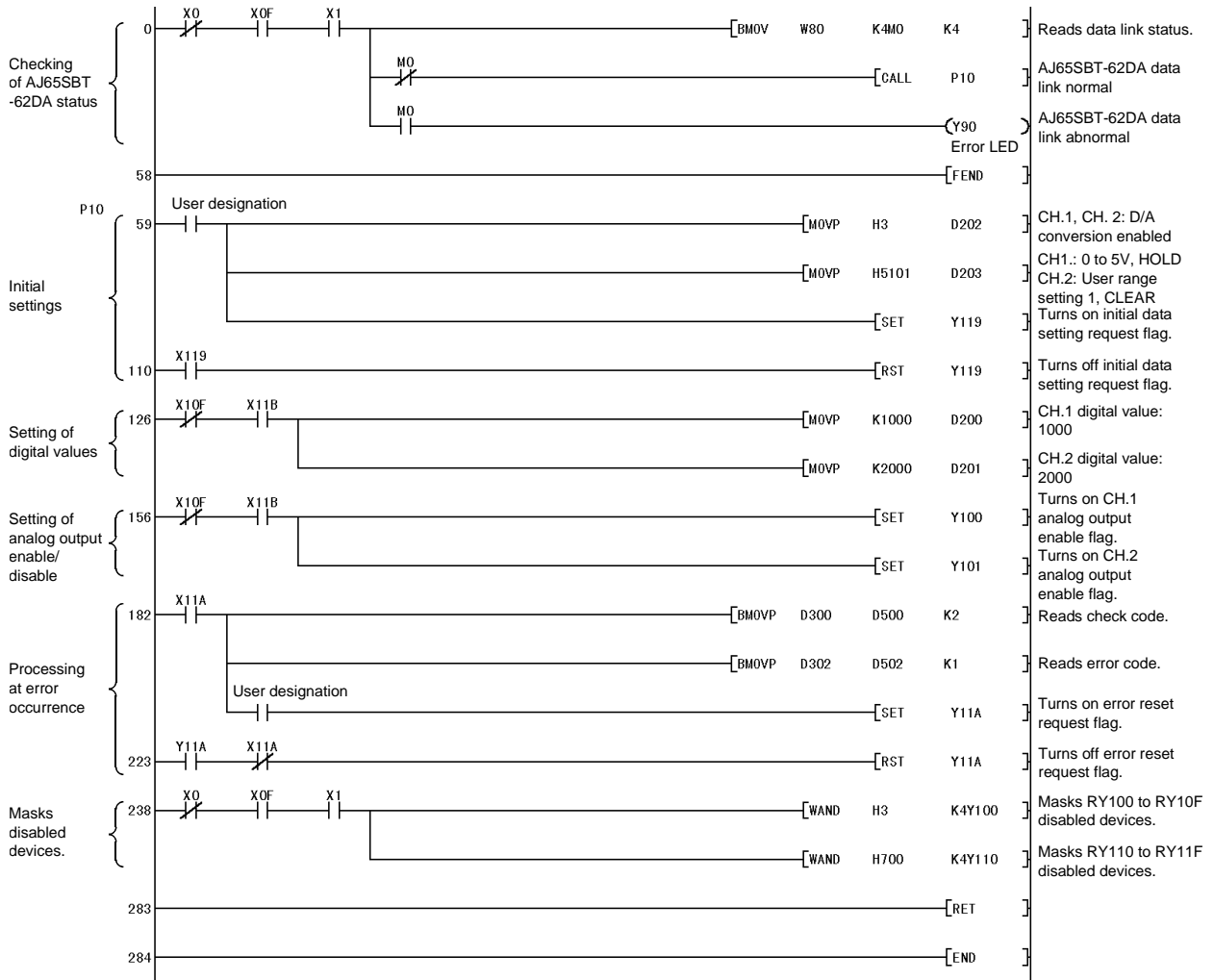



5.2.4 Program examples for use of the QCPU (Q mode)

The program examples in this section are created under the following conditions.  
GPPW is used to set the network and automatic refresh parameters.

[Relationships between PLC CPU, master module and AJ65SBT-62DA]

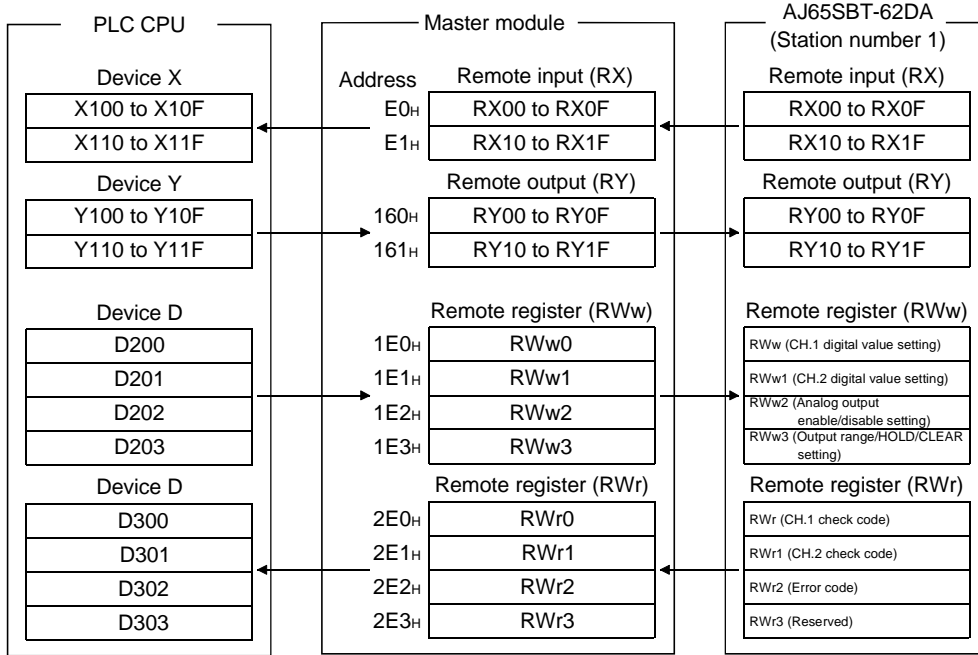

[Initial settings]

- D/A conversion enabled channels ..... Channels 1, 2
- Input range setting ..... Channel 1: 0 to 5V  
Channel 2: User range setting 1
- HOLD/CLEAR setting ..... Channel 1: HOLD  
Channel 2: CLEAR
- Digital value setting ..... Channel 1: 1000  
Channel 2: 2000
- Analog output enabled channels ..... Channels 1, 2

## [Network parameter setting]

	1
Start I/O No	0000
Operational setting	Operational settings
Type	Master station ▼
Master station data link type	PLC parameter auto start ▼
Mode	Online (Remote net mode) ▼
All connect count	1
Remote input(RX)	
Remote output(RY)	
Remote register(RW/r)	
Remote register(RW/w)	
Special relay(SB)	
Special register(SW)	
Retry count	3
Automatic reconnection station count	1
Stand by master station No.	
PLC down select	Stop ▼
Scan mode setting	Asynchronous ▼
Delay information setting	0
Station information setting	Station information
Remote device station initial setting	Initial settings
Interrupt setting	Interrupt settings

Station No.	Station type	Exclusive station count	Reserve/invalid station select	Intelligent buffer select(word) ▲		
				Send	Receive	Automatic
1/1	Remote device station ▼	Exclusive station 1 ▼	No setting ▼			▼

## [Automatic refresh parameter setting]

	1
Start I/O No	0000
Operational setting	Operational settings
Type	Master station ▼
Master station data link type	PLC parameter auto start ▼
Mode	Online (Remote net mode) ▼
All connect count	1
Remote input(RX)	X100
Remote output(RY)	Y100
Remote register(RW/r)	D300
Remote register(RW/w)	D200
Special relay(SB)	SB0
Special register(SW)	SW0
Retry count	3
Automatic reconnection station count	1
Stand by master station No.	
PLC down select	Stop ▼
Scan mode setting	Asynchronous ▼
Delay information setting	0
Station information setting	Station information
Remote device station initial setting	Initial settings
Interrupt setting	Interrupt settings

(1) Program for power-on

At power-on, the initial setting of the AJ65SBT-62DA can be made easily using the remote device station initialization procedure registration function.

(a) Setting the target station number

Set the station number to which initial setting will be made.

Set the target station number to "1".

Remote device station initial setting: Target station number setting: Module 1							
	Target station No.	No. of registered procedures			Target station No.	No. of registered procedures	
1	1		Regist procedure	9			Regist procedure
2			Regist procedure	10			Regist procedure

(b) Setting the procedure registration

When the initial data processing request flag (RX (n+1) 8) turns on and the remote device station initialization procedure registration (SB0D) is set, the following data are registered to the AJ65SBT-62DA.

Procedure Execution Condition	Execution	Number
Initial data processing request flag (RX(n+1)8) turns on	Channels 1, 2 are set to D/A conversion enable.	1)
	Output range setting of channel 1 is set to 0 to 5V. Output range setting of channel 2 is set to user range setting 1. HOLD/CLEAR setting of channel 1 is set to HOLD. HOLD/CLEAR setting of channel 2 is set to CLEAR..	2)
	Initial data processing complete flag (RY(n+1)8) is turned on.	3)
	Initial data setting request flag (RY(n+1)9) is turned on.	4)
	Initial data processing request flag (RX(n+1)8) turns off	Initial data processing complete flag (RY(n+1)8) is turned off.
Initial data setting complete flag (RX(n+1)9) turns on	Initial data setting request flag (RY(n+1)9) is turned off.	6)

(c) Setting results

The setting results of 1) to 6) are shown below.

Remote device station initial setting: Procedure registration module 1: Target station 1										
Input format		<input type="text" value="HEX."/>								
Execute Flag	Operational condition	Execuational condition			Details of execution					
		Condition Device	Device Number	Execute Condition	Write Device	Device Number	Write Data			
Execute	Set new	RX	18	ON	R'w'w	02	0003			
Execute	Same as prev.set	RX	18	ON	R'w'w	03	5101			
Execute	Same as prev.set	RX	18	ON	RY	18	ON			
Execute	Same as prev.set	RX	18	ON	RY	19	ON			
Execute	Set new	RX	18	OFF	RY	18	OFF			
Execute	Set new	RX	19	ON	RY	19	OFF			

(d) Program example

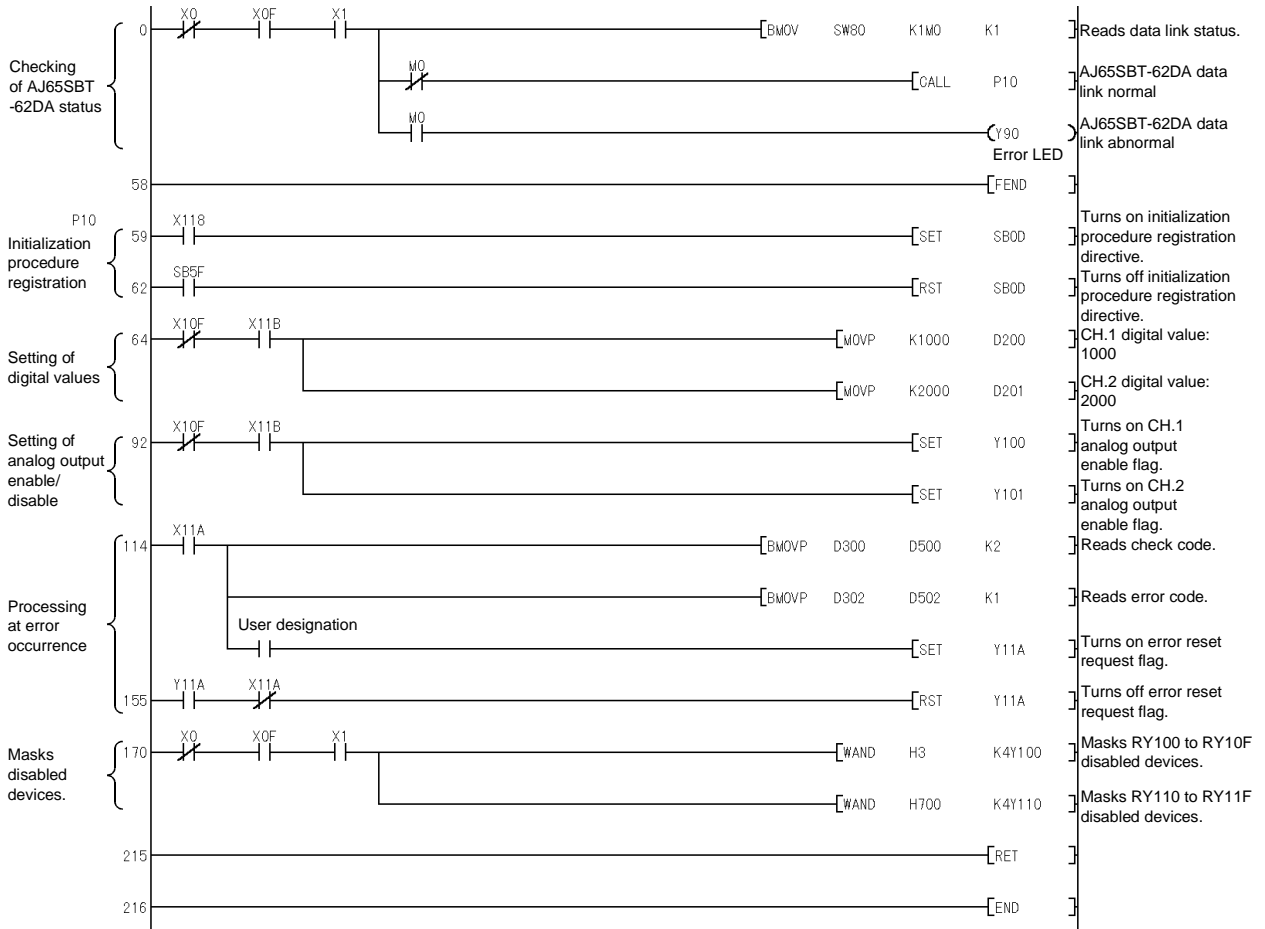

(2) Program for initial data changing

When any initial data (D/A conversion enable/disable channel, output range) is changed, the remote device station initialization procedure registration function is unusable.

Using a sequence program, change the initial data.

The program example for initial data changing is shown below.

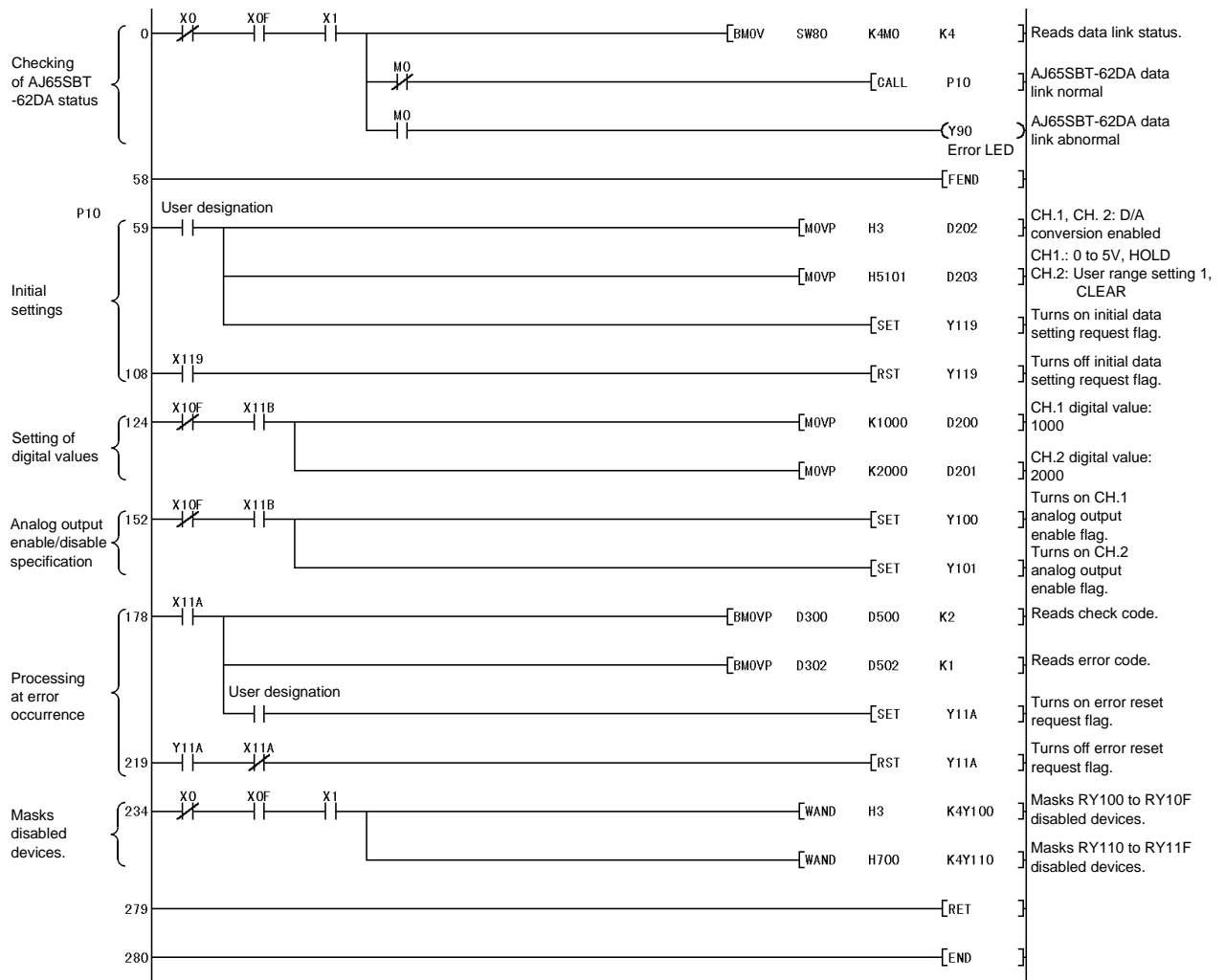

## 6 TROUBLESHOOTING

The details of the errors which may occur when using the AJ65SBT-62DA and troubleshooting are described.

### 6.1 Error Code List

When the data is written from the PLC CPU to the master module, and an error occurs (AJ65SBT-62DA "RUN" LED flashes), the error code is stored to the AJ65SBT-62DA remote register RWrn+2.

Table 6.1 Error Code List (Errors Detected by AJ65SBT-62DA)

Error Code (Hexadecimal).	Cause	Corrective Action
110 □	The set digital value is outside the setting range.	Correct the digital value to within the setting range.
200 □	The output range setting is outside the setting range.	Correct the output range setting to within the setting range.
	All channels are not set to any of "user range settings 1 to 3" at offset/gain setting (in the test mode).	When making offset/gain setting (in the test mode), set all channels to any of "user range settings 1 to 3".

The □ indicates the channel number where the error occurred.

- (1) For the digital value setting error, the "RUN" LED flickers at intervals of 0.5s and D/A conversion is performed using the upper or lower limit value.  
For the output range setting error, the "RUN" LED flickers at intervals of 0.1s and D/A conversion is not performed on all channels.
- (2) When multiple errors occurred, the error code of the first error is stored, but the other errors are not stored.
- (3) The error code reset is performed by turning on the error reset request flag (RY (n+1) A).

6.2 Using the LED Indications to Check Errors

This section explains how to check errors using the LED indications of the AJ65SBT-62DA.

Refer to the PLC CPU and master module user's manual for issues regarding the PLC CPU and master module.

(1) When the AJ65SBT-62DA "PW" LED is off

Check Item	Corrective Action
Is 24VDC power on?	Check the external power supply.
Is the voltage of the 24VDC power supply within the specified value?	Set the voltage value to within the range 20.4 to 26.4V.

(2) When the AJ65SBT-62DA "RUN" LED flickers

Check item	Corrective action
Is the LED flickering at 0.1s intervals in the normal mode?	<ol style="list-style-type: none"> <li>Using the error code (RWm+2), check the channel at which the output range setting error has occurred.</li> <li>Make correction to the sequence program or GPPW setting.</li> </ol>
Is the LED flickering at 0.5s intervals in the normal mode?	<ol style="list-style-type: none"> <li>Using the error code (RWm+2), check the channel at which the digital value setting error has occurred.</li> <li>Check the check code (RWm, RWm+1) of the channel at which the error has occurred.</li> <li>Make correction to the sequence program.</li> </ol>
Is the LED flickering at 0.1s intervals in the test mode?	Set all channels to any of "user range settings 1 to 3" in output range setting.
Is the LED flickering at 0.5s intervals in the test mode?	Change the offset/gain adjustment to within the available setting range.

(3) When the AJ65SBT-62DA "RUN" LED is off

Check item	Corrective action
Has the watchdog timer error occurred?	Using the link special registers (SW0084 to SW0087) of the master module, check the watchdog timer error and power on the AJ65SBT-62DA again. If the "RUN" LED is not lit after power is switched on again, the possible cause is a hardware fault. Contact your nearest Mitsubishi representative.
Has the TEST terminals (across 8-9) been shorted to enter the test mode?	After making offset/gain adjustment, open the TEST terminals (across 8-9).

(4) When the AJ65SBT-62DA "L RUN" LED is off

Communications are broken.

For details, refer to troubleshooting in the user's manual of the master module used.

## (5) When the AJ65SBT-62DA "L ERR." LED flickers at fixed intervals

Check item	Corrective action
Has the station number or transmission speed setting switch position been changed during normal operation?	After correcting the setting switch setting, switch power on again.
Is the station number or transmission speed setting switch faulty?	If the "L ERR." LED has begun flickering though switch setting change was not made during operation, the possible cause is a hardware fault. Contact your nearest Mitsubishi representative.

## (6) When the AJ65SBT-62DA "L ERR." LED flickers at unfixed intervals

Check item	Corrective action
Have you forgotten fitting the terminal resistor?	Check whether the termination resistor is fitted. If it is not connected, connect it and switch power on again.
Is the module or CC-Link dedicated cable affected by noise?	Earth both ends of the shield wire of the CC-Link dedicated cable to the protective earth conductor via SLD and FG of the corresponding module. Earth the FG terminal of the module without fail. When carrying out wiring in piping, earth the pipe without fail.

## (7) When the AJ65SBT-62DA "L ERR." LED is on

Check item	Corrective action
Are the station number and transmission speed correct?	Set the correct station number and transmission speed.



6.3 Troubleshooting for the Case where the "ERR." LED of the Master Station Flickers



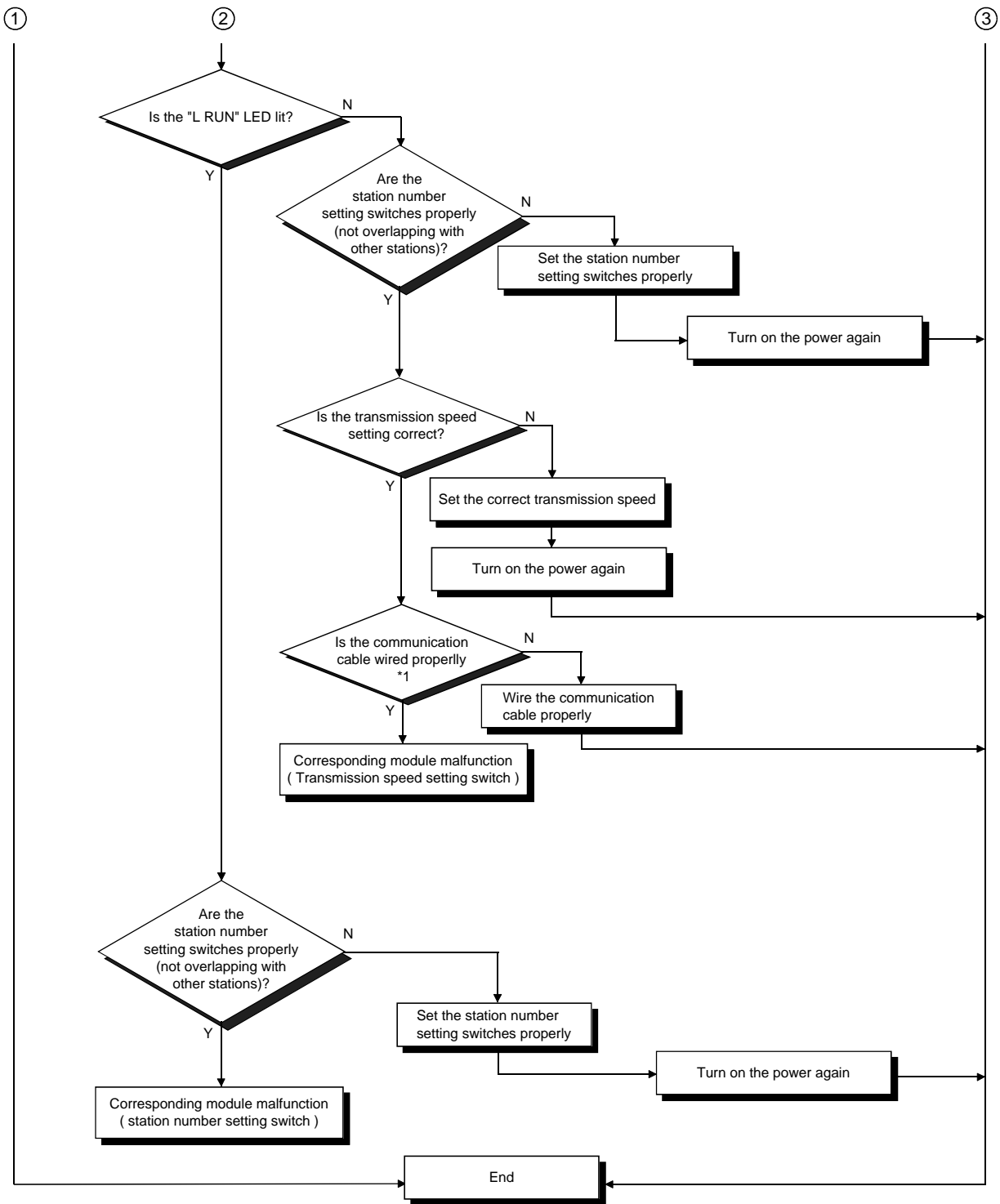

\*1Check for a short, reversed connection, wire breakage, terminal resistor, FG connection, overall distance and station-to-station distance.



APPENDIX

Appendix1 Comparison between This Product and Conventional Product

- (1) Comparison in performance between this product and conventional product  
The following table gives performance comparison between the AJ65SBT-62DA and conventional product (AJ65BT-64DAV/DAI).

Performance Comparison between AJ65SBT-62DA and Conventional Product

Item	Specifications																																				
	AJ65SBT-62DA		AJ65BT-64DAV	AJ65BT-64DAI																																	
	Voltage output	Current output																																			
Digital input	-4096 to +4095		0 to 4095																																		
Analog output	Voltage: -10 to +10VDC (external load resistance: 2kΩ to 1MΩ)		Current: 0 to 20mADC (external load resistance: 0Ω to 600Ω)																																		
I/O characteristics Maximum resolution	<table border="1"> <thead> <tr> <th></th> <th>Digital Input Value</th> <th>Output Range</th> <th>Max. Resolution</th> </tr> </thead> <tbody> <tr> <td rowspan="3">Voltage</td> <td rowspan="2">-4000 to +4000</td> <td>-10V to +10V</td> <td rowspan="2">2.5mV</td> </tr> <tr> <td>User range setting 1 (-10V to +10V)</td> </tr> <tr> <td rowspan="2">0 to 4000</td> <td>0 to 5V</td> <td>1.25mV</td> </tr> <tr> <td>User range setting 2 (0 to 5V)</td> <td>1.0mV</td> </tr> <tr> <td rowspan="3">Current</td> <td rowspan="3">0 to 4000</td> <td>0 to 20mA</td> <td>5μA</td> </tr> <tr> <td>4 to 20mA</td> <td rowspan="2">4μA</td> </tr> <tr> <td>User range setting 3 (0 to 20mA)</td> </tr> </tbody> </table>			Digital Input Value	Output Range	Max. Resolution	Voltage	-4000 to +4000	-10V to +10V	2.5mV	User range setting 1 (-10V to +10V)	0 to 4000	0 to 5V	1.25mV	User range setting 2 (0 to 5V)	1.0mV	Current	0 to 4000	0 to 20mA	5μA	4 to 20mA	4μA	User range setting 3 (0 to 20mA)	<table border="1"> <thead> <tr> <th></th> <th>Digital Input Value</th> <th>Output Range</th> <th>Max. Resolution</th> </tr> </thead> <tbody> <tr> <td>DAV</td> <td>-2000 to +2000</td> <td>-10V to +10V</td> <td>5mA</td> </tr> <tr> <td>DAI</td> <td>0 to 4000</td> <td>4 to 20mA</td> <td>4μA</td> </tr> </tbody> </table>			Digital Input Value	Output Range	Max. Resolution	DAV	-2000 to +2000	-10V to +10V	5mA	DAI	0 to 4000	4 to 20mA	4μA
		Digital Input Value	Output Range	Max. Resolution																																	
Voltage	-4000 to +4000	-10V to +10V	2.5mV																																		
		User range setting 1 (-10V to +10V)																																			
	0 to 4000	0 to 5V	1.25mV																																		
User range setting 2 (0 to 5V)		1.0mV																																			
Current	0 to 4000	0 to 20mA	5μA																																		
		4 to 20mA	4μA																																		
		User range setting 3 (0 to 20mA)																																			
	Digital Input Value	Output Range	Max. Resolution																																		
DAV	-2000 to +2000	-10V to +10V	5mA																																		
DAI	0 to 4000	4 to 20mA	4μA																																		
Output range changing	Yes		No																																		
Offset/gain setting	Yes																																				
Accuracy	Ambient temperature 0 to 55°C	±0.4% (accuracy relative to maximum value of analog output value)		±1.0% (accuracy relative to maximum value of analog output value)																																	
	Ambient temperature 25 ± 5°C	±0.2% (accuracy relative to maximum value of analog output value)		—																																	
Max. conversion speed	1ms/1 channel																																				
Output short-circuit protection	Yes																																				
Number of analog output points	2 channels/1 module		4 channels/1 module																																		
Number of occupied I/O points	1 station occupied (RX/RV: 32 points each, RWr/RWw: 4 points each)		2 stations occupied (RX/RV: 32 points each, RWr/RWw: 8 points each)																																		
Connected terminal block	7-point, 2-piece terminal block (transmission, power supply) Direct-coupled, 18-point terminal block (analog output section) (M3 screw)		27-point terminal block (M3.5 screw)																																		
Applicable wire size	0.3 to 0.75mm <sup>2</sup>		0.75 to 2.00 mm <sup>2</sup>																																		
Applicable crimping terminal	RAV1.25-3.5		RAV1.25-3.5, RAV2-3.5																																		
24VDC internal current consumption (A)	0.16		0.18	0.27																																	
Weight (kg)	0.20		0.4																																		
Outline dimensions (mm)	118(W) × 50(H) × 40(D)		151.9(W) × 65(H) × 63(D)																																		



(2) Precautions for replacing the conventional product (AJ65BT-64DAV/DAI) with the AJ65SBT-62DA

In the existing system using the conventional product (AJ65BT-64DAV/DAI), the following instructions must be noted when changing the AJ65BT-64DAV/DAI for the AJ65SBT-62DA.

- (a) Since the AJ65SBT-62DA occupies one station (the AJ65BT-64DAV/DAI occupies two stations), the station information setting in the network parameters must be changed.
- (b) As the remote I/O signals and remote register settings are different between the two models, the program of the conventional model cannot be utilized.
- (c) Because of the differences in shape and layout between the terminal blocks, you cannot use the terminal block of the conventional module as it is.
- (d) The offset/gain setting method differs. For details, refer to Section 4.4.
- (e) The ways to set the station number and transmission speed setting switches are different. For details, refer to Section 4.3.

Appendix2 External dimension diagram

The outline dimension drawing of the AJ65SBT-62DA is shown below.

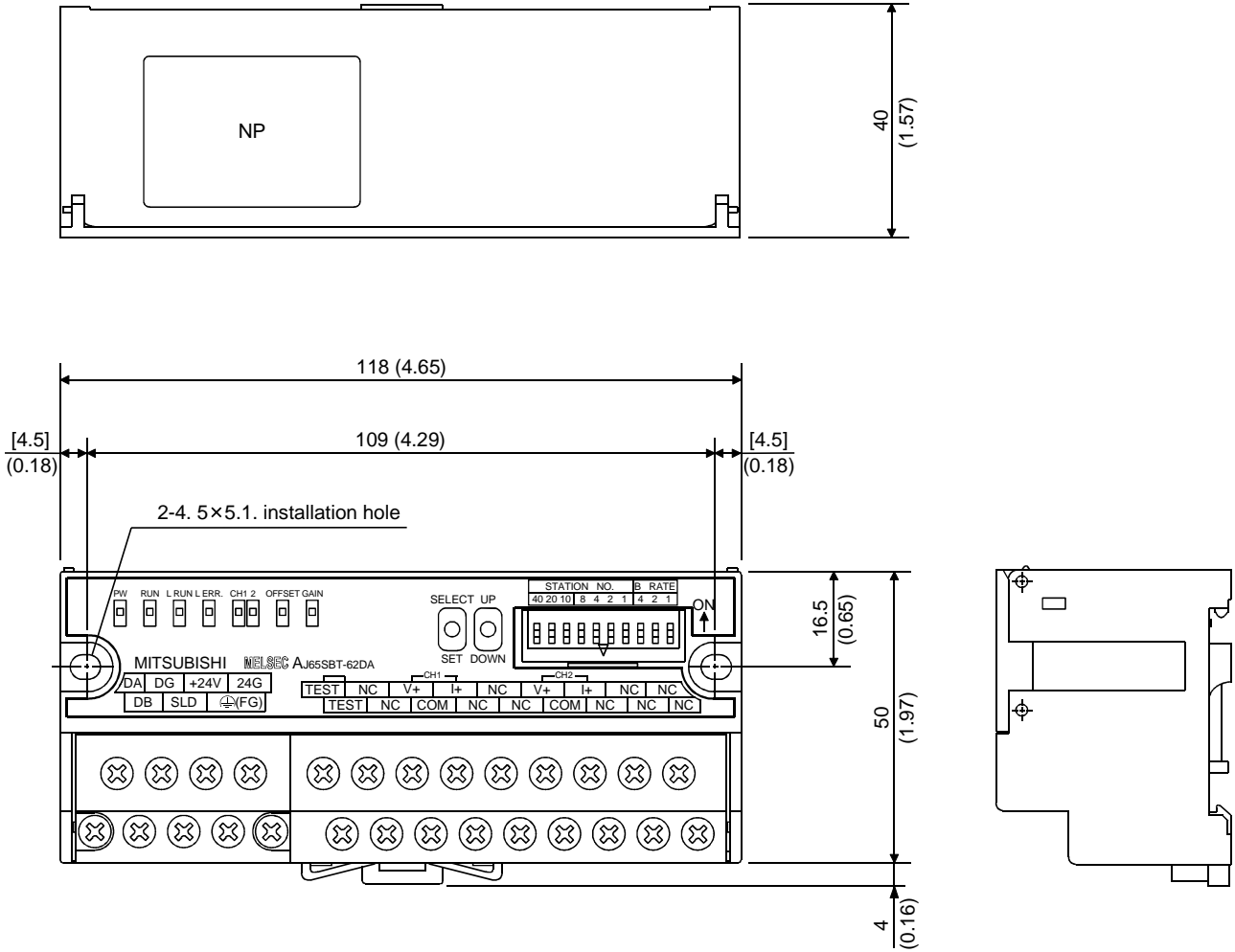

Unit : mm(inch)



## INDEX

### [A]

- Absolute maximum output ..... 3-2
- Accuracy ..... 3-2,3-6
- Allocation of the remote register ..... 3-13
- Analog output ..... 3-2
- Analog output enable/disable setting..... 3-14
- Analog output status combination list ..... 3-9
- Analog output value ..... 3-6
- Applicable master module..... 2-2

### [C]

- CC-Link dedicated cable ..... 4-8
- CC-Link dedicated instruction ..... 2-2
- CH.  analog output enable/disable flag .... 3-12
- CH.  check code ..... 3-16
- CH.  digital value setting ..... 3-14
- Comparison in performance between this product and conventional product ..... App-1
- Conversion speed ..... 3-7
- Current output characteristic..... 3-5

### [D]

- D/A conversion enable/disable function ..... 3-8
- D/A output enable/disable function ..... 3-8
- Data link cable wiring ..... 4-8
- Digital input ..... 3-2
- DIN rail ..... 3-2,4-2,4-4

### [E]

- E<sup>2</sup>PROM write error flag ..... 3-11
- Error code ..... 3-16,6-1
- Error reset request flag ..... 3-12
- Error status flag ..... 3-11
- External dimension diagram ..... App-3
- External power supply ..... 3-2

### [F]

- Facing direction of the module installation .... 4-7
- Function list..... 3-8
- Function to specify hold or clear of the analog output when the PLC CPU is in the STOP status ..... 3-8

### [G]

- Gain value..... 3-3

- General specification ..... 3-1

### [I]

- I/O conversion characteristic ..... 3-3
- Initial data processing complete flag ..... 3-12
- Initial data processing request flag ..... 3-11
- Initial data setting complete flag ..... 3-11
- Initial data setting request flag ..... 3-12
- Internal current consumption ..... 3-2

### [M]

- Maintenance and inspection..... 4-9
- Maximum resolution..... 3-2

### [N]

- Name of each part ..... 4-3
- Number of analog output points ..... 3-2
- Number of occupied stations ..... 3-2

### [O]

- Offset value ..... 3-3
- Offset/gain adjusting LED ..... 4-3
- Offset/gain setting ..... 4-5
- Operation status display LED ..... 4-3
- Output range changing function ..... 3-8
- Output range/HOLD/CLEAR setting ..... 3-15
- Output short-circuit protection ..... 3-2

### [P]

- Performance specification ..... 3-2
- Pre-Operation procedure ..... 4-1
- Precautions for replacing the conventional product (AJ65BT-64DAV/DAI) with the AJ65SBT-62DA..... App-2
- Precautions when handling ..... 4-1
- Program examples for use of the ACPU/QCPU (A mode)(dedicated instructions) ..... 5-7
- Program examples for use of the ACPU/QCPU (A mode)(FROM/TO instructions) ..... 5-2
- Program examples for use of the QCPU(Q mode) ..... 5-16
- Program examples for use of the QnACPU.. 5-12
- Programming procedure ..... 5-1



[R]	
Remote I/O signal list .....	3-10
Remote READY .....	3-11
Resolution.....	3-6
[S]	
SELECT/SET switch .....	4-3
Station number setting .....	4-7
Station number setting switch.....	4-4
[T]	
Terminal block.....	3-2,4-4
Terminal number .....	4-3
Test mode flag.....	3-11
Tightening torque range .....	4-2
Transmission speed setting switch.....	4-4
Troubleshooting.....	6-1
Troubleshooting for the case where the "ERR." LED of the master station flickers .....	6-4
[U]	
UP/DOWN switch.....	4-4
User range setting .....	3-4,3-5
[V]	
Voltage output characteristic.....	3-4
[W]	
Weight.....	3-2
Wiring.....	4-8
Wiring of module with external equipment .....	4-9



# WARRANTY

Please confirm the following product warranty details before starting use.

## 1. Gratis Warranty Term and Gratis Warranty Range

If any faults or defects (hereinafter "Failure") found to be the responsibility of Mitsubishi occurs during use of the product within the gratis warranty term, the product shall be repaired at no cost via the dealer or Mitsubishi Service Company. Note that if repairs are required at a site overseas, on a detached island or remote place, expenses to dispatch an engineer shall be charged for.

### [Gratis Warranty Term]

The gratis warranty term of the product shall be for one year after the date of purchase or delivery to a designated place.

Note that after manufacture and shipment from Mitsubishi, the maximum distribution period shall be six (6) months, and the longest gratis warranty term after manufacturing shall be eighteen (18) months. The gratis warranty term of repair parts shall not exceed the gratis warranty term before repairs.

### [Gratis Warranty Range]

- (1) The range shall be limited to normal use within the usage state, usage methods and usage environment, etc., which follow the conditions and precautions, etc., given in the instruction manual, user's manual and caution labels on the product.
- (2) Even within the gratis warranty term, repairs shall be charged for in the following cases.
  1. Failure occurring from inappropriate storage or handling, carelessness or negligence by the user. Failure caused by the user's hardware or software design.
  2. Failure caused by unapproved modifications, etc., to the product by the user.
  3. When the Mitsubishi product is assembled into a user's device, Failure that could have been avoided if functions or structures, judged as necessary in the legal safety measures the user's device is subject to or as necessary by industry standards, had been provided.
  4. Failure that could have been avoided if consumable parts (battery, backlight, fuse, etc.) designated in the instruction manual had been correctly serviced or replaced.
  5. Failure caused by external irresistible forces such as fires or abnormal voltages, and Failure caused by force majeure such as earthquakes, lightning, wind and water damage.
  6. Failure caused by reasons unpredictable by scientific technology standards at time of shipment from Mitsubishi.
  7. Any other failure found not to be the responsibility of Mitsubishi or the user.

## 2. Onerous repair term after discontinuation of production

- (1) Mitsubishi shall accept onerous product repairs for seven (7) years after production of the product is discontinued. Discontinuation of production shall be notified with Mitsubishi Technical Bulletins, etc.
- (2) Product supply (including repair parts) is not possible after production is discontinued.

## 3. Overseas service

Overseas, repairs shall be accepted by Mitsubishi's local overseas FA Center. Note that the repair conditions at each FA Center may differ.

## 4. Exclusion of chance loss and secondary loss from warranty liability

Regardless of the gratis warranty term, Mitsubishi shall not be liable for compensation to damages caused by any cause found not to be the responsibility of Mitsubishi, chance losses, lost profits incurred to the user by Failures of Mitsubishi products, damages and secondary damages caused from special reasons regardless of Mitsubishi's expectations, compensation for accidents, and compensation for damages to products other than Mitsubishi products and other duties.

## 5. Changes in product specifications

The specifications given in the catalogs, manuals or technical documents are subject to change without prior notice.

## 6. Product application

- (1) In using the Mitsubishi MELSEC programmable logic controller, the usage conditions shall be that the application will not lead to a major accident even if any problem or fault should occur in the programmable logic controller device, and that backup and fail-safe functions are systematically provided outside of the device for any problem or fault.
- (2) The Mitsubishi general-purpose programmable logic controller has been designed and manufactured for applications in general industries, etc. Thus, applications in which the public could be affected such as in nuclear power plants and other power plants operated by respective power companies, and applications in which a special quality assurance system is required, such as for Railway companies or National Defense purposes shall be excluded from the programmable logic controller applications.

Note that even with these applications, if the user approves that the application is to be limited and a special quality is not required, application shall be possible.

When considering use in aircraft, medical applications, railways, incineration and fuel devices, manned transport devices, equipment for recreation and amusement, and safety devices, in which human life or assets could be greatly affected and for which a particularly high reliability is required in terms of safety and control system, please consult with Mitsubishi and discuss the required specifications.

HEADQUARTERS	EUROPEAN REPRESENTATIVES	EUROPEAN REPRESENTATIVES	EUROPEAN REPRESENTATIVES
<b>MITSUBISHI ELECTRIC EUROPE B.V.</b> German Branch Gothaer Straße 8 <b>D-40880 Ratingen</b> Phone: +49 (0)2102 486-0 Fax: +49 (0)2102 486-1120 e mail: megfamail@meg.mee.com	<b>EUROPE</b> <b>GEVA AUSTRIA</b> Wiener Straße 89 <b>AT-2500 Baden</b> Phone: +43 (0)2252 / 85 55 20 Fax: +43 (0)2252 / 488 60 e mail: office@geva.at <b>TEHNIKON BELARUS</b> Oktjabrskaya 16/5, Ap 704 <b>BY-220030 Minsk</b> Phone: +375 (0)17 / 2104626 Fax: +375 (0)17 / 2275830 e mail: tehnikon@belsonet.net <b>Getronics b.v. BELGIUM</b> Control Systems Pontbeeklaan 43 <b>BE-1731 Asse-Zellik</b> Phone: +32 (0)2 / 467 17 51 Fax: +32 (0)2 / 467 17 45 e mail: infoautomation@getronics.com <b>TELECON CO. BULGARIA</b> Motion Control Automation b.v. Markenweg 5 <b>BG-1756 Sofia</b> Phone: +359 (0)2 / 97 44 058 Fax: +359 (0)2 / 97 44 061 e mail: — <b>INEA CR d.o.o. CROATIA</b> Losinjska 4 a <b>HR-10000 Zagreb</b> Phone: +385 (0) 1 / 36 940-01 Fax: +385 (0) 1 / 36 940-03 e mail: inea@inea.hr <b>AutoCont CZECH REPUBLIC</b> Control Systems s.r.o. Nemocnicni 12 <b>CZ-70200 Ostrava 2</b> Phone: +420 59 / 6152 111 Fax: +420 59 / 6152 562 e mail: consys@autocont.cz <b>louis poulsen DENMARK</b> industri & automation Geminivej 32 <b>DK-2670 Greve</b> Phone: +45 (0)43 / 95 95 95 Fax: +45 (0)43 / 95 95 91 e mail: lpia@lpmail.com <b>UTU Elektrotehnika AS ESTONIA</b> Pärnu mnt.160i <b>EE-10621 Tallinn</b> Phone: +372 (0)6 / 51 72 80 Fax: +372 (0)6 / 51 72 88 e mail: utu@utu.ee <b>UTU POWEL OY FINLAND</b> Box 236 <b>FIN-28101 Pori</b> Phone: +358 (0)2 / 550 800 Fax: +358 (0)2 / 550 8841 e mail: tehoelektroniikka@urhotuominen.fi <b>UTECO A.B.E.E. GREECE</b> 5, Mavrogenous Str. <b>GR-18542 Piraeus</b> Phone: +302 (0)10 / 42 10 050 Fax: +302 (0)10 / 42 12 033 e mail: uteco@uteco.gr <b>Meltrade Automatika Kft. HUNGARY</b> 55, Harmat St. <b>HU-1105 Budapest</b> Phone: +36 (0)1 / 2605 602 Fax: +36 (0)1 / 2605 602 e mail: office@meltrade.hu <b>SIA POWEL LATVIA</b> Lienes iela 28 <b>LV-1009 Riga</b> Phone: +371 784 2280 Fax: +371 784 2281 e mail: utu@utu.lv	<b>UAB UTU POWEL LITHUANIA</b> Savanoriu Pr. 187 <b>LT-2053 Vilnius</b> Phone: +370 (0)52323-101 Fax: +370 (0)52322-980 e mail: powel@utu.lt <b>Intehsis Srl MOLDOVA</b> Cuza-Voda 36/1-81 <b>MD-2061 Chisinau</b> Phone: +373 (0)2 / 562 263 Fax: +373 (0)2 / 562 263 e mail: intehsis@mdl.net <b>Getronics b.v. NETHERLANDS</b> Control Systems Donauweg 2 B <b>NL-1043 AJ Amsterdam</b> Phone: +31 (0)20 / 587 6700 Fax: +31 (0)20 / 587 6839 e mail: info.gia@getronics.com <b>Motion Control NETHERLANDS</b> Automation b.v. Markenweg 5 <b>NL-7051 HS Varsseveld</b> Phone: +31 (0)315 / 257 260 Fax: +31 (0)315 / 257 269 e mail: — <b>Beijer Electronics AS NORWAY</b> Teglverksveien 1 <b>NO-3002 Drammen</b> Phone: +47 (0)32 / 24 30 00 Fax: +47 (0)32 / 84 85 77 e mail: info@beijer.no <b>MPL Technology Sp. z o.o. POLAND</b> ul. Sliczna 36 <b>PL-31-444 Kraków</b> Phone: +48 (0)12 / 632 28 85 Fax: +48 (0)12 / 632 47 82 e mail: krakow@mpl.pl <b>Sirius Trading &amp; Services srl ROMANIA</b> Str. Biharia Nr. 67-77 <b>RO-013981 Bucuresti 1</b> Phone: +40 (0) 21 / 201 1146 Fax: +40 (0) 21 / 201 1148 e mail: sirius@siriustrading.ro <b>ACP Autocomp a.s. SLOVAKIA</b> Chalupkova 7 <b>SK-81109 Bratislava</b> Phone: +421 (02)5292-2254 Fax: +421 (02)5292-2248 e mail: info@acp-autocomp.sk <b>INEA d.o.o. SLOVENIA</b> Stegne 11 <b>SI-1000 Ljubljana</b> Phone: +386 (0)1 513 8100 Fax: +386 (0)1 513 8170 e mail: inea@inea.si <b>Beijer Electronics AB SWEDEN</b> Box 426 <b>S-20124 Malmö</b> Phone: +46 (0)40 / 35 86 00 Fax: +46 (0)40 / 35 86 02 e mail: info@beijer.de <b>ECONOTEC AG SWITZERLAND</b> Postfach 282 <b>CH-8309 Nürensdorf</b> Phone: +41 (0)1 / 838 48 11 Fax: +41 (0)1 / 838 48 12 e mail: info@econotec.ch <b>GTS TURKEY</b> Darülaceze Cad. No. 43A KAT: 2 <b>TR-80270 Okmeydani-Istanbul</b> Phone: +90 (0)212 / 320 1640 Fax: +90 (0)212 / 320 1649 e mail: gts@turk.net	<b>CSC Automation UKRAINE</b> 15, M. Raskova St., Fl. 10, Off. 1010 <b>UA-02002 Kiev</b> Phone: +380 (0)44 / 238 83 16 Fax: +380 (0)44 / 238 83 17 e mail: csc-a@csc-a.kiev.ua
			<b>EURASIAN REPRESENTATIVE</b> <b>CONSUS RUSSIA</b> Promyshlennaya St. 42 <b>RU-198099 St Petersburg</b> Phone: +7 812 / 325 36 53 Fax: +7 812 / 325 36 53 e mail: consus@consus.spb.ru <b>ELEKTROSTYLE RUSSIA</b> ul. Garschina 11 <b>RU-140070 Moscow Oblast</b> Phone: +7 095 / 557 9756 Fax: +7 095 / 746 8880 e mail: mjuly@elektrostyle.ru <b>ELEKTROSTYLE RUSSIA</b> Krasnij Prospekt 220-1, Office 312 <b>RU-630049 Novosibirsk</b> Phone: +7 3832 / 10 66 18 Fax: +7 3832 / 10 66 26 e mail: elo@elektrostyle.ru <b>ICOS RUSSIA</b> Ryazanskij Prospekt, 8A, Office 100 <b>RU-109428 Moscow</b> Phone: +7 095 / 232 0207 Fax: +7 095 / 232 0327 e mail: mail@icos.ru <b>SMENA RUSSIA</b> Polzunova 7 <b>RU-630051 Novosibirsk</b> Phone: +7 095 / 416 4321 Fax: +7 095 / 416 4321 e mail: smena-nsk@yandex.ru <b>SSMP Rosgidromontazh Ltd RUSSIA</b> 23, Lesoparkovaya Str. <b>RU-344041 Rostov On Don</b> Phone: +7 8632 / 36 00 22 Fax: +7 8632 / 36 00 26 e mail: — <b>STC Drive Technique RUSSIA</b> Poslannikov per., 9, str.1 <b>RU-107005 Moscow</b> Phone: +7 095 / 786 21 00 Fax: +7 095 / 786 21 01 e mail: info@privod.ru
			<b>MIDDLE EAST REPRESENTATIVE</b> <b>SHERF Motion Techn. Ltd ISRAEL</b> Rehov Hamerkava 19 <b>IL-58851 Holon</b> Phone: +972 (0)3 / 559 54 62 Fax: +972 (0)3 / 556 01 82 e mail: —
			<b>AFRICAN REPRESENTATIVE</b> <b>CBI Ltd SOUTH AFRICA</b> Private Bag 2016 <b>ZA-1600 Isando</b> Phone: +27 (0)11 / 928 2000 Fax: +27 (0)11 / 392 2354 e mail: cbi@cbi.co.za