

MITSUBISHI **TRANSISTORIZED INVERTER**

FR-S500 Series DIN Rail Mounting Attachments

< FR-UDA01, 02, 03 >

Thank you for choosing the Mitsubishi transistorized inverter option unit.

This instruction manual gives handling information and precautions for using this product. Incorrect handling might cause an unexpected fault. Before using the equipment, always read this manual carefully to use it to its optimum.

Please forward this manual to the end user.

Safety Instructions

- ⚠ While power is on or for some time after power-off, do not touch the inverter and DIN rail mounting attachment as they are hot and you may get burnt.
- ⚠ Carry the product in a correct manner according to its weight. Not doing so can cause injury. Also, be careful of the edges.
- ⚠ Always inspect the product after mounting. Not doing so can cause it to drop due to incorrect installation, resulting in an accident.

This product is an attachment designed to mount the FR-S500 series inverter to a DIN rail.

1. Preparation

- (1) Check the attachment type to confirm that the product is as you ordered.
- (2) The table on the right indicates the inverters that are applicable to the DIN rail mounting attachments. Do not use the attachments with other inverters.

Model	Inverter Capacity (kW)		
	FR-UDA01	FR-UDA02	FR-UDA03
FR-S520-□	0.1K, 0.2K, 0.4K, 0.75K	1.5K, 2.2K	3.7K
FR-S520S-□	0.1K, 0.2K, 0.4K, 0.75K	1.5K	—

- (3) The attachments are applicable to the DIN, EN, IEC standard-compliant 35mm wide rails given on the right. Do not use the attachments with the other rails.

Applicable Rail	Rail Specifications
TH35-7.5	Rail width 35mm, height 7.5mm
TH35-15	Rail width 35mm, height 15mm

- (4) Due to the mechanical strength of the rail, the rail mounting screw pitch should be not more than the corresponding value indicated in the following table.

DIN rail mounting screw pitch L (mm)

Mounted Model	FR-S520-0.1K, 0.2K FR-S520S-0.1K, 0.2K	FR-S520-0.4K, 0.75K FR-S520S-0.4K, 0.75K	FR-S520-1.5K, 2.2K FR-S520S-1.5K	FR-S520-3.7K
(a) Channel mounting	TH35-7.5	100	—	—
	TH35-15	500	500	200
(b) Enclosure surface mounting	TH35-7.5	250	150	—
	TH35-15	500	500	500

—: Must not be mounted

Note: If the mounted models of different pitches are used together on the same DIN rail, choose the minimum mounting screw pitch.

Mounting screw pitch

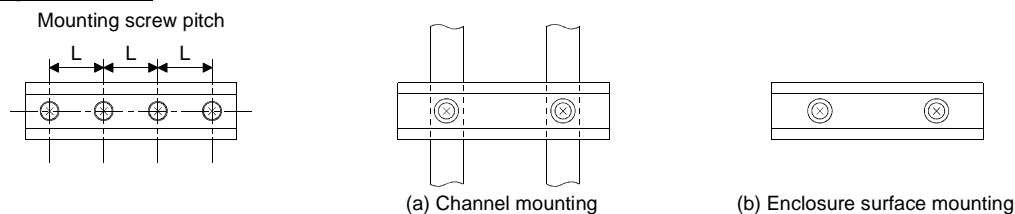

- (5) When the inverter is mounted on the DIN rail, it can endure continuous vibration equivalent to (approximately) 2.45m/s^2 . Vibration conforms to JIS C0911.

Frequency	Acceleration	Amplitude	Sweep Count
10 to 55Hz	—	0.075mm	10 times (1 octave*/1 minute)
55 to 150Hz	9.8m/s^2	—	

*Octave indicates the interval between any two frequencies having a ratio of 2 to 1.

2. Installation of DIN Rail Mounting Attachment to Inverter

- (1) When installing the DIN rail mounting attachment to the inverter, first remove the inverter's front cover in accordance with the inverter instruction manual.
- (2) Precautions for installation
 - 1) Be careful so that the mounting screws do not enter the inverter.

Installation of FR-UDA01

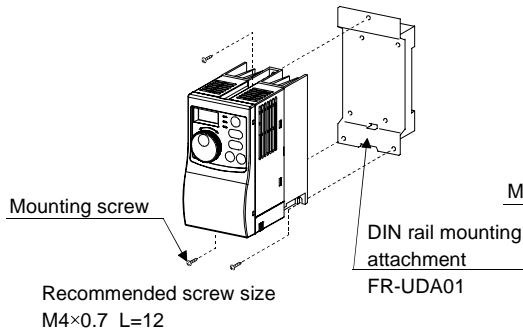

Installation of FR-UDA02, 03

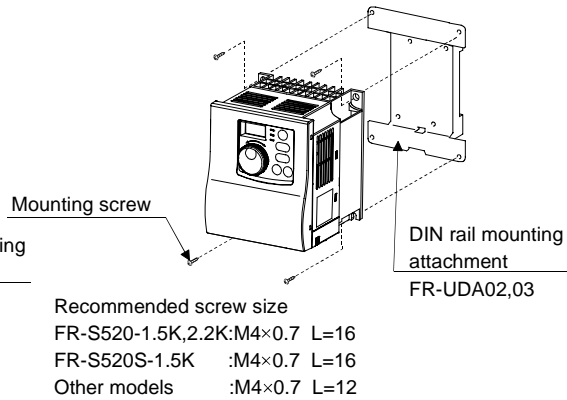

3. Mounting and Dismounting to and from DIN Rail

- (1) Mounting

To prevent the inverter from dropping due to a mounting fault, insert the top of the groove into the top side of the DIN rail and press the inverter against the DIN rail to fix. Make sure that the inverter has been fixed securely.

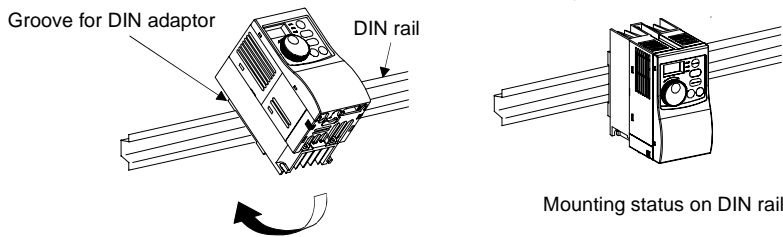

- (Inspection after mounting)

To check whether the inverter has been mounted to the DIN rail securely, there will be no problem if the inverter is not removed from the DIN rail by applying force (about 3N•m) as shown below. If it is removed, mount it to the DIN rail and then push it up.

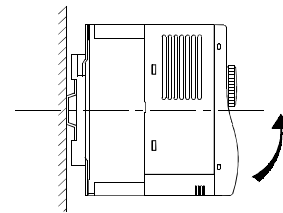

- (2) Dismounting
 - 1) Using a flat-blade screwdriver (6x100), pull down the hook at the bottom of the DIN adaptor.
 - 2) With the hook pulled down, pull the inverter toward you to dismount it from the DIN rail.

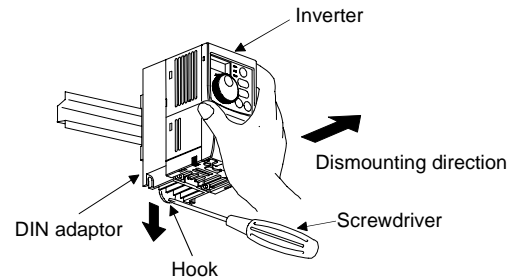

4. DIN Rail Mounting Attachment Outline Dimension Drawings

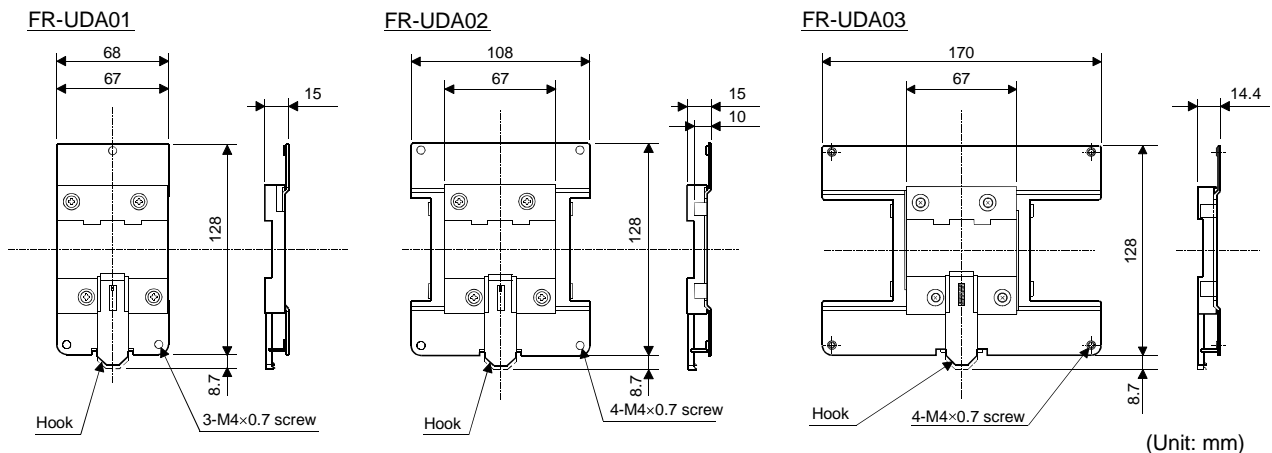

MITSUBISHI ELECTRIC CORPORATION
 HEAD OFFICE: MITSUBISHI DENKI BLDG MARUNOUCHI TOKYO 100-8310