

# FX1N

## FX1N-1DA-BD Analog Output Expansion Board

### User's Manual

JY992D96401B

This manual contains text, diagrams and explanations which will guide the reader in the correct installation, safe use and operation of the FX1N-1DA-BD Analog Output Expansion Board and should be read and understood before attempting to install or use the unit. Further information can be found in the associated manuals list below.

Specifications are subject to change without notice

### Guidelines for the Safety of the User and Protection of the FX1N-1DA-BD Analog Output Expansion Board.

This manual has been written to be used by trained and competent personnel. The definition of such a person or persons is as follows:

- Any engineer using the product associated with this manual, should be of a competent nature, trained and qualified to the local and national standards. These engineers should be fully aware of all aspects of safety with regards to automated equipment.
- Any commissioning or service engineer must be of a competent nature, trained and qualified to the local and national standards.
- All operators of the completed equipment should be trained to use that product in a safe and coordinated manner in compliance to established safety practices.

**Note:** The term 'completed equipment' refers to a third party constructed device which contains or uses the product associated with this manual.

#### Note's on the Symbols Used in this Manual

At various times through out this manual certain symbols will be used to highlight points of information which are intended to ensure the users personal safety and protect the integrity of equipment.



- 1) Indicates that the identified danger **WILL** cause physical and property damage.



- 2) Indicates that the identified danger could **POSSIBLY** cause physical and property damage.

- Under no circumstances will Mitsubishi Electric be liable or responsible for any consequential damage that may arise as a result of the installation or use of this equipment.
- All examples and diagrams shown in this manual are intended only as an aid to understanding the text, not to guarantee operation. Mitsubishi Electric will accept no responsibility for actual use of the product based on these illustrative examples.
- Owing to the very great variety in possible application of this equipment, you must satisfy yourself as to its suitability for your specific application.

### Associated Manual

	Manual Name	Manual Number	Description
	FX1S Series Programmable controllers Hardware Manual	JY992D83901	Describes contents related to hardware of FX1S Series PLC, such as specifications, wiring and installation.
	FX1N Series Programmable controllers Hardware Manual	JY992D89301	Describes contents related to hardware of FX1N Series PLC, such as specifications, wiring and installation.
⊙	FX Series of Programmable controllers Programming Manual II	JY992D88101	Describes instructions in FX1S/FX1N/FX2N/FX2NC series.

⊙ Indispensable manual

# 1. Introduction

The FX<sub>1N</sub>-1DA-BD analog output expansion board (hereafter called "1DA" or "expansion board") is to be installed in an FX<sub>1S</sub> or FX<sub>1N</sub> series PLC, to increase the analog output by 1 point.

## 1.1 Features of 1DA

- Analog output of 1 point can be increased using 1DA. If a 1DA is used, internal mounting in the top of the PLC means there is no need for a change to the installation area of the PLC.
- Voltage output (0 ~ 10V) or current output (4 ~ 20mA) for digital to analog conversion can be set by switching a dedicated special auxiliary relay.  
Moreover, the digital value for conversion is stored in a dedicated special data register, as shown in the table below.  
However, the digital to analog conversion characteristics cannot be adjusted.

**Table 1.1: Allocated Device**

Device	Description
M8114	Switch of output mode OFF: Voltage output mode (0 ~ 10V) ON: Current output mode (4 ~ 20mA)
D8114	Digital value for analog output

## 1.2 External Dimensions and Each Part Name

Dimensions: mm (inches) Accessory: Top cover for board ×1,  
M3 self-tapping screw ×3 (to fix top cover ×1, to mount board ×2)

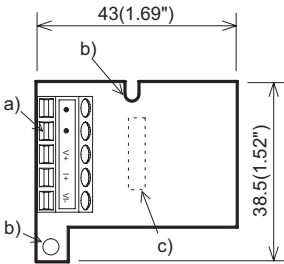

- a) Terminals to connect analog module  
The top face of this terminal block is higher than the top face of the panel cover of the programmable controller by approximately 7mm (0.28").

**Table 1.2: Allocation of Terminals**

Terminal name	Content
•	No connection (DO NOT use this terminal)
V+	Voltage output terminal
I+	Current output terminal
VI-	Common terminal for analog output

- b) Mounting holes (2-  $\varnothing$ 4.0 / 0.16")  
c) Connector for PLC

## 1.3 System Configuration

- Only one expansion board can be used on one FX<sub>1S</sub> and FX<sub>1N</sub> PLC main unit.  
Do not try to install two or more expansion board. (They will not function)
- The 1DA cannot be used together with a FX<sub>1N</sub>-EEPROM-8L or FX<sub>1N</sub>-5DM.

## 1.4 Applicable PLC

**Table 1.3: Applicable Programmable Controller**

PLC Type	Applicable version
FX <sub>1S</sub> series	V2.00 or later
FX <sub>1N</sub> series	V2.00 or later

# 2. Specifications

## 2.1 General Specifications

Same as the programmable controller main unit. (Refer to the programmable controller main unit manual)

## 2.2 Power Supply Specifications

Power supplied by internal feed of the programmable controller main unit.

## 2.3 Performance Specifications

**Table 2.1: Performance Specifications**

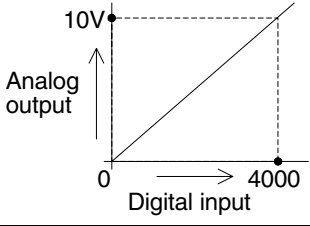
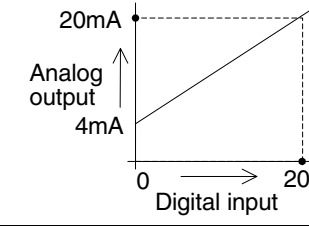
Item	Specification	
	Voltage output	Current output
Range of analog output	DC 0 ~ 10V (External load resistance 2k ~ 1MΩ)	DC 4 ~ 20mA (External load resistance 500Ω or less)
Digital output	12bit binary	
Resolution	2.5mV (10V / 4000)	8μA {(20mA - 4mA) / 2000}
Integrated accuracy	±1% Against the full scale (0 ~ 10V: ±0.1V)	±1% Against the full scale (4 ~ 20mA: ±0.16mA)
D/A conversion time	Approx. 10ms (D/A conversion is started after the END instruction)*1	
Input characteristics	0 ~ 4000 are adjusted to 0 ~ 10V when the external load is 2kΩ. 	0 ~ 2000 are adjusted to 4 ~ 20mA when the external load is 250Ω. 
Occupied point	0 points (1DA is not subject to the standard maximum number of control points in the host PLC, as it operates via a data register).	

\*1 The D/A conversion is started following the END statement and analogue signals will be sent after 10ms. Further analogue signals will be sent after the D/A conversion triggered by the next END statement. Converting the present value stored in D8114 is dependent on PLC scan time.



### Note:

- When external load resistance is 2kΩ, the overall accuracy of voltage output is adjusted "±1%"  
If external load becomes larger than 2kΩ, the output voltage will increase slightly. When the load is 1MΩ, the output voltage becomes about 3% higher than the correct value.
- When using current output, be sure to have an external load resistance of 500Ω or less. If the load is greater than 500Ω, the output current will be lower than the correct value.

## 3. Installation



### Caution:

- Cut off all phases of power source before installing / removing or performing wiring work on the expansion board in order to avoid electric shock or damage of product.
- After the installation and wiring etc. replace the PLCs top cover before power ON.



### Note:

- Securely install the expansion board, and fix to the PLC. Defective contact can cause malfunction.
- The tightening torque for fixing the board or top cover is 0.3 ~ 0.6 N·m. Tighten securely to avoid malfunction.



### Note:

Only one expansion board can be used per main unit of FX1S and FX1N series PLC. Do not try to install two or more expansion boards.  
Moreover, the 1DA cannot be used with the FX1N-EEPROM-8L or FX1N-5DM.

The following is a generic explanation of how to install an expansion board to the PLC.

- Top cover for expansion board
- M3 self-tapping screw to mount expansion board
- M3 self-tapping screw to fix top cover
- External port for optional equipment
- Expansion board

Note: Do not remove this screw.

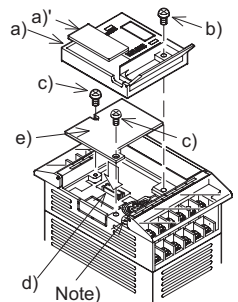

- Remove the top cover of the main unit and keep.
- Plug expansion board "e)" into the external port "d)".
- Fix expansion board to main unit using M3 self-tapping screws "c)". (Tightening torque: 0.3 ~ 0.6N·m)
- Attach top cover for expansion board "a)" removing section "a)" to expose connector etc.
- Secure top cover with M3 self-tapping screw "b)". (Tightening torque: 0.3 ~ 0.6N·m)

## 4. Wiring



### Caution:

Cut off all phases of power source before installing / removing or performing wiring work on the expansion board in order to avoid electric shock or damage of product.



### Note:

- Do not lay signal cable near to high voltage power cable or house them in the same trunking duct. Effects of noise or surge induction may occur. Keep signal cables a safe distance of more than 100 mm (3.94") from these power cables.
- Ground the shield wire or the shield of a shielded cable. Do not, however, ground at the same point as high voltage lines.
- Never solder the end of any cables.  
Make sure that the number of connected cables is not more than the unit has been designed for.
- Never connect cables of a non permitted size.
- Fix cables so that any stress is not directly applied on the terminal block or the cable connection area.
- The terminal tightening torque is 0.5 ~ 0.6 N·m. Tighten securely to avoid malfunction.
- Do not use to the  terminal.

### 4.1 Applicable cables

- Use AWG26 ~ 16 for connection with output equipment.
- The maximum tightening torque is 0.5 ~ 0.6 N·m.
- When using a different type of cable, defective contact at the terminal is possible. Use a crimp terminal to achieve a good contact.

**Table 4.1: Liner and Sectional Area**

Linear	Sectional Area (mm <sup>2</sup> )	Terminal
AWG26	0.1288	Stranded cable: Remove sheath, twist core wires, then connect cable. Single cable: Remove sheath, then connect cable.
:	:	
:	:	
AWG16	1.309	

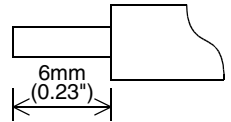

### 4.2 Wiring

#### 4.2.1 Voltage Output Mode

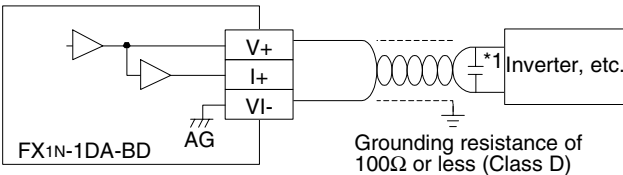

\*1 Connect a 0.1 ~ 0.47μF at 25V DC capacitor in position"\*1" when there will be a lot of noise.

#### 4.2.2 Current Output Mode

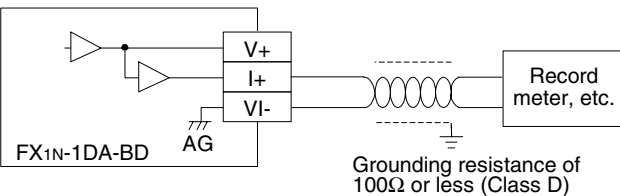

## 5. Example Program

An analog output is converted from a digital value (D8114) using the DA conversion characteristic specified by special auxiliary relay M8114 at each END instruction.

### 5.1 Allocated Device

Table 5.1: Allocation of Device

Device	Description
M8114	Switch of output mode OFF: Voltage output mode (0 ~ 10V) ON: Current output mode (4 ~ 20mA)
D8114	Digital value (When power supply is turned ON, D8114 will initials to "0".)



#### Note:

This D/A conversion is done regardless of the RUN/STOP status of the PLC. Any time power is supplied to the PLC when the 1DA is attached, the analog value in D8114 will be output. The analog output value will continue to be output when the PLC status is changed from RUN to STOP!

### 5.2 Basic Example Program



#### Note:

Drive M8114 which specifies the digital to analog conversion characteristic with M8000 ("a" type contact of the RUN monitor) or M8001 ("b" type contact of the RUN monitor). Do not change the ON/OFF state while the digital to analog conversion is operating. The Digital to analog conversion is not executed correctly when M8114 is turned ON and OFF during the conversion process.

#### 5.2.1 Voltage Output Mode

The following program example sets the voltage output mode, and a digital value in D0 is converted to analog.

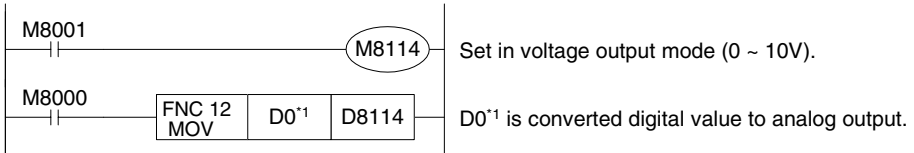

\*1 If a digital value is not stored in D0, D8114 can be used directly for other instructions.

#### 5.2.2 Current Output Mode

The following program example sets the current output mode, and a digital value in D2 is converted to analog.

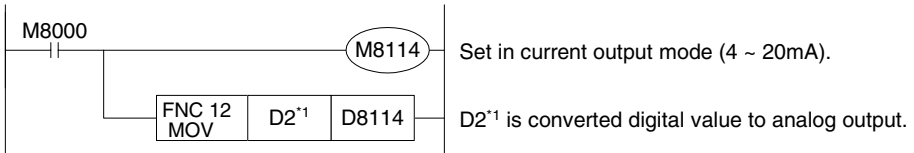

\*1 If a digital value is not stored in D2, D8114 can be used directly for other instructions.

### 5.3 Example Application Program

As the 1DA does not have Offset and Gain capabilities, if values are required outside the standard specification range, additional program commands are required to either multiply or divide the conversion values. For an example application program, please see FX programming manual II.



#### Note:

- Accuracy and resolution of the digital to analog conversion are different from the specification because of the additional program commands.
- The original range of the analog output is not changed.

### 5.3.1 Example Application Program 1

In voltage output mode, the 1DA converts digital values from 0 ~ 4000 to the analog output of 0 ~ 10 Volts. If using a digital range of 0 ~ 10000 in the program, the range must be converted to 0 ~ 4000 as shown in the programming example below. Digital values for conversion to analog are stored in D8114. The analog output does not have exact resolution of 2.5mV because the digital value is converted from 0 ~ 10000 to a range of 0 ~ 4000.

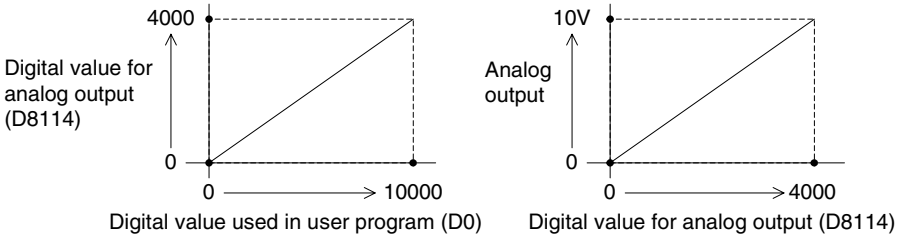

If a digital value in the range of 0 ~ 10000 is used in D0, please see below.

$$\text{Digital value used in user program: (D8114)} = 2 \times D0 \div 5$$

The value of D0 is given as a multiple of five.

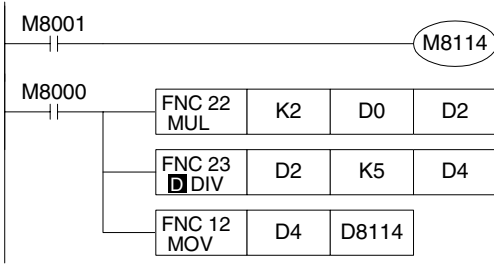

### 5.3.2 Example Application Program 2

In current output mode, the 1DA converts digital values from 0 ~ 2000 to the analog output of 0 ~ 20 mA. If using a digital range of 0 ~ A in the program, the range must be converted to 0 ~ 4000 as shown in the programming example below. Digital values for conversion to analog are stored in D8114. The analog output does not have exact resolution of 8 μA because the digital value is converted from 0 ~ A to range of 0 ~ 2000. A > 0.

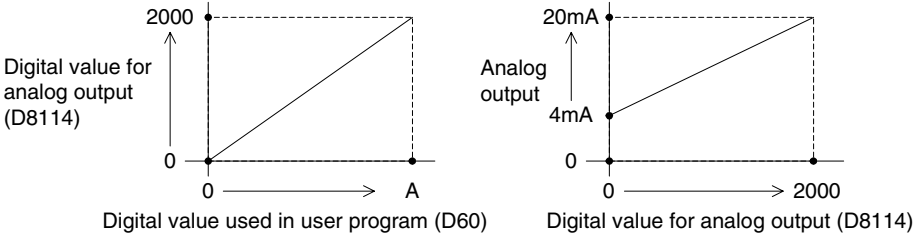

If a digital value in the range of 0 ~ A is used in D60, please see below.

$$\begin{aligned} \text{Digital value used in user program: D8114} &= 2000 \times D60 \div A \\ &= 2000 \times D60 \div 10000 \text{ (In } A = 10000 \text{ case)} \\ &= D60 \div 5 \end{aligned}$$

The value of D60 is given as a multiple of five

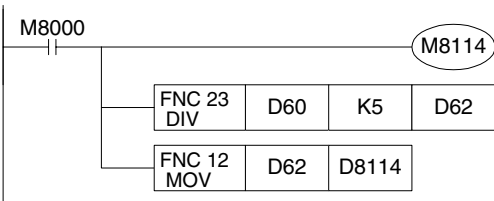

Manual number : JY992D96401

Manual revision : B

Date : JULY 2004

# FX<sub>1N</sub>

## FX1N-1DA-BD Analog Output Expansion Board

### User's Manual

JY992D96401B

This manual contains text, diagrams and explanations which will guide the reader in the correct installation, safe use and operation of the FX1N-1DA-BD Analog Output Expansion Board and should be read and understood before attempting to install or use the unit. Further information can be found in the associated manuals list below.

Specifications are subject to change without notice

### Guidelines for the Safety of the User and Protection of the FX1N-1DA-BD Analog Output Expansion Board.

This manual has been written to be used by trained and competent personnel. The definition of such a person or persons is as follows:

- Any engineer using the product associated with this manual, should be of a competent nature, trained and qualified to the local and national standards. These engineers should be fully aware of all aspects of safety with regards to automated equipment.
- Any commissioning or service engineer must be of a competent nature, trained and qualified to the local and national standards.
- All operators of the completed equipment should be trained to use that product in a safe and coordinated manner in compliance to established safety practices.

**Note:** The term 'completed equipment' refers to a third party constructed device which contains or uses the product associated with this manual.

### Note's on the Symbols Used in this Manual

At various times through out this manual certain symbols will be used to highlight points of information which are intended to ensure the users personal safety and protect the integrity of equipment.



- Indicates that the identified danger **WILL** cause physical and property damage.



- Indicates that the identified danger could **POSSIBLY** cause physical and property damage.

- Under no circumstances will Mitsubishi Electric be liable or responsible for any consequential damage that may arise as a result of the installation or use of this equipment.
- All examples and diagrams shown in this manual are intended only as an aid to understanding the text, not to guarantee operation. Mitsubishi Electric will accept no responsibility for actual use of the product based on these illustrative examples.
- Owing to the very great variety in possible application of this equipment, you must satisfy yourself as to its suitability for your specific application.

### Associated Manual

Manual Name	Manual Number	Description
FX1S Series Programmable controllers Hardware Manual	JY992D83901	Describes contents related to hardware of FX1S Series PLC, such as specifications, wiring and installation.
FX1N Series Programmable controllers Hardware Manual	JY992D89301	Describes contents related to hardware of FX1N Series PLC, such as specifications, wiring and installation.
FX Series of Programmable controllers Programming Manual II	JY992D88101	Describes instructions in FX1S/FX1N/FX2N/FX2NC series.

Ⓞ Indispensable manual

## 1. Introduction

The FX1N-1DA-BD analog output expansion board (hereafter called "1DA" or "expansion board") is to be installed in an FX1S or FX1N series PLC, to increase the analog output by 1 point.

### 1.1 Features of 1DA

- Analog output of 1 point can be increased using 1DA. If a 1DA is used, internal mounting in the top of the PLC means there is no need for a change to the installation area of the PLC.
- Voltage output (0 ~ 10V) or current output (4 ~ 20mA) for digital to analog conversion can be set by switching a dedicated special auxiliary relay. Moreover, the digital value for conversion is stored in a dedicated special data register, as shown in the table below. However, the digital to analog conversion characteristics cannot be adjusted.

**Table 1.1: Allocated Device**

Device	Description
M8114	Switch of output mode OFF: Voltage output mode (0 ~ 10V) ON: Current output mode (4 ~ 20mA)
D8114	Digital value for analog output

### 1.2 External Dimensions and Each Part Name

Dimensions: mm (inches) Accessory: Top cover for board ×1, M3 self-tapping screw ×3 (to fix top cover ×1, to mount board ×2)

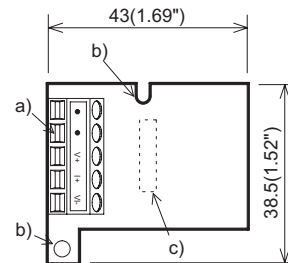

- Terminals to connect analog module  
The top face of this terminal block is higher than the top face of the panel cover of the programmable controller by approximately 7mm (0.28").

**Table 1.2: Allocation of Terminals**

Terminal name	Content
•	No connection (DO NOT use this terminal)
V+	Voltage output terminal
I+	Current output terminal
VI-	Common terminal for analog output

- Mounting holes (2- ∅4.0 / 0.16")
- Connector for PLC

### 1.3 System Configuration

- Only one expansion board can be used on one FX1S and FX1N PLC main unit. Do not try to install two or more expansion board. (They will not function)
- The 1DA cannot be used together with a FX1N-EEPROM-8L or FX1N-5DM.

### 1.4 Applicable PLC

**Table 1.3: Applicable Programmable Controller**

PLC Type	Applicable version
FX1S series	V2.00 or later
FX1N series	V2.00 or later

## 2. Specifications

### 2.1 General Specifications

Same as the programmable controller main unit. (Refer to the programmable controller main unit manual)

### 2.2 Power Supply Specifications

Power supplied by internal feed of the programmable controller main unit.

## 2.3 Performance Specifications

**Table 2.1: Performance Specifications**

Item	Specification	
	Voltage output	Current output
Range of analog output	DC 0 ~ 10V (External load resistance 2k ~ 1MΩ)	DC 4 ~ 20mA (External load resistance 500Ω or less)
Digital output	12bit binary	
Resolution	2.5mV (10V / 4000)	8μA {(20mA - 4mA) / 2000}
Integrated accuracy	±1% Against the full scale (0 ~ 10V: ±0.1V)	±1% Against the full scale (4 ~ 20mA: ±0.16mA)
D/A conversion time	Approx. 10ms (D/A conversion is started after the END instruction)*1	
Input characteristics	0 ~ 4000 are adjusted to 0 ~ 10V when the external load is 2kΩ. 	0 ~ 2000 are adjusted to 4 ~ 20mA when the external load is 250Ω. 
Occupied point	0 points (1DA is not subject to the standard maximum number of control points in the host PLC, as it operates via a data register).	

\*1 The D/A conversion is started following the END statement and analogue signals will be sent after 10ms. Further analogue signals will be sent after the D/A conversion triggered by the next END statement. Converting the present value stored in D8114 is dependent on PLC scan time.



### Note:

- When external load resistance is 2kΩ, the overall accuracy of voltage output is adjusted "±1%". If external load becomes larger than 2kΩ, the output voltage will increase slightly. When the load is 1MΩ, the output voltage becomes about 3% higher than the correct value.
- When using current output, be sure to have an external load resistance of 500Ω or less. If the load is greater than 500Ω, the output current will be lower than the correct value.

## 3. Installation



### Caution:

- Cut off all phases of power source before installing / removing or performing wiring work on the expansion board in order to avoid electric shock or damage of product.
- After the installation and wiring etc. replace the PLCs top cover before power ON.



### Note:

- Securely install the expansion board, and fix to the PLC. Defective contact can cause malfunction.
- The tightening torque for fixing the board or top cover is 0.3 ~ 0.6 N·m. Tighten securely to avoid malfunction.



### Note:

Only one expansion board can be used per main unit of FX1S and FX1N series PLC. Do not try to install two or more expansion boards. Moreover, the 1DA cannot be used with the FX1N-EEPROM-8L or FX1N-5DM.

The following is a generic explanation of how to install an expansion board to the PLC.

- Top cover for expansion board
- M3 self-tapping screw to mount expansion board
- M3 self-tapping screw to fix top cover
- External port for optional equipment
- Expansion board

Note: Do not remove this screw.

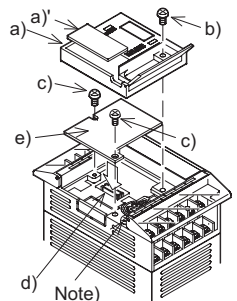

- Remove the top cover of the main unit and keep.
- Plug expansion board "e)" into the external port "d)".
- Fix expansion board to main unit using M3 self-tapping screws "c)". (Tightening torque: 0.3 ~ 0.6N·m)
- Attach top cover for expansion board "a)" removing section "a)" to expose connector etc.
- Secure top cover with M3 self-tapping screw "b)". (Tightening torque: 0.3 ~ 0.6N·m)



## 4. Wiring



### Caution:

Cut off all phases of power source before installing / removing or performing wiring work on the expansion board in order to avoid electric shock or damage of product.



### Note:

- Do not lay signal cable near to high voltage power cable or house them in the same trunking duct. Effects of noise or surge induction may occur. Keep signal cables a safe distance of more than 100 mm (3.94") from these power cables.
- Ground the shield wire or the shield of a shielded cable. Do not, however, ground at the same point as high voltage lines.
- Never solder the end of any cables. Make sure that the number of connected cables is not more than the unit has been designed for.
- Never connect cables of a non permitted size.
- Fix cables so that any stress is not directly applied on the terminal block or the cable connection area.
- The terminal tightening torque is 0.5 ~ 0.6 N·m. Tighten securely to avoid malfunction.
- Do not use to the terminal.

### 4.1 Applicable cables

- Use AWG26 ~ 16 for connection with output equipment.
- The maximum tightening torque is 0.5 ~ 0.6 N·m.
- When using a different type of cable, defective contact at the terminal is possible. Use a crimp terminal to achieve a good contact.

Table 4.1: Liner and Sectional Area

Linear	Sectional Area (mm <sup>2</sup> )	Terminal
AWG26	0.1288	Stranded cable: Remove sheath, twist core wires, then connect cable. Single cable: Remove sheath, then connect cable.
:	:	
AWG16	1.309	

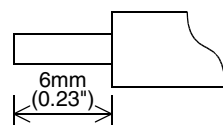

### 4.2 Wiring

#### 4.2.1 Voltage Output Mode

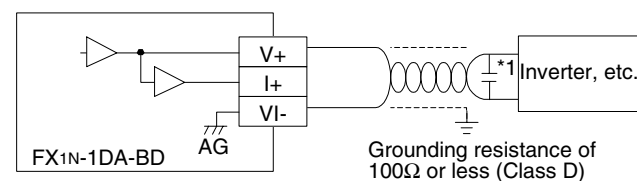

\*1 Connect a 0.1 ~ 0.47μF at 25V DC capacitor in position\*\*1 when there will be a lot of noise.

#### 4.2.2 Current Output Mode

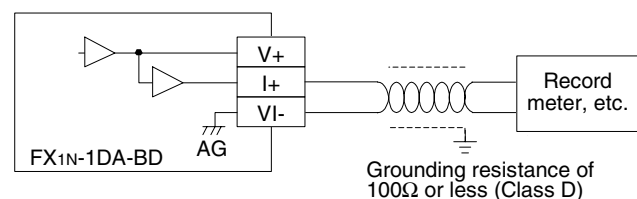

## 5. Example Program

An analog output is converted from a digital value (D8114) using the DA conversion characteristic specified by special auxiliary relay M8114 at each END instruction.

### 5.1 Allocated Device

Table 5.1: Allocation of Device

Device	Description
M8114	Switch of output mode OFF: Voltage output mode (0 ~ 10V) ON: Current output mode (4 ~ 20mA)
D8114	Digital value (When power supply is turned ON, D8114 will initials to "0".)



### Note:

This D/A conversion is done regardless of the RUN/STOP status of the PLC. Any time power is supplied to the PLC when the 1DA is attached, the analog value in D8114 will be output. The analog output value will continue to be output when the PLC status is changed from RUN to STOP!

### 5.2 Basic Example Program



### Note:

Drive M8114 which specifies the digital to analog conversion characteristic with M8000 ("a" type contact of the RUN monitor) or M8001 ("b" type contact of the RUN monitor). Do not change the ON/OFF state while the digital to analog conversion is operating. The Digital to analog conversion is not executed correctly when M8114 is turned ON and OFF during the conversion process.

#### 5.2.1 Voltage Output Mode

The following program example sets the voltage output mode, and a digital value in D0 is converted to analog.

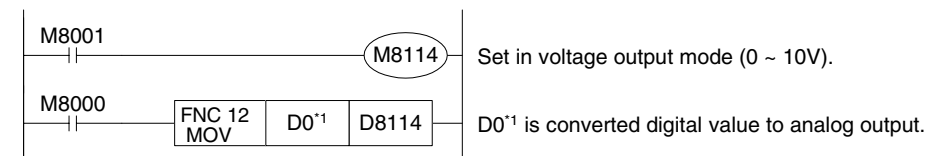

\*1 If a digital value is not stored in D0, D8114 can be used directly for other instructions.

#### 5.2.2 Current Output Mode

The following program example sets the current output mode, and a digital value in D2 is converted to analog.

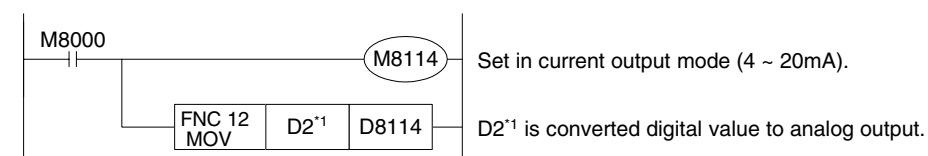

\*1 If a digital value is not stored in D2, D8114 can be used directly for other instructions.

### 5.3 Example Application Program

As the 1DA does not have Offset and Gain capabilities, if values are required outside the standard specification range, additional program commands are required to either multiply or divide the conversion values. For an example application program, please see FX programming manual II.



### Note:

- Accuracy and resolution of the digital to analog conversion are different from the specification because of the additional program commands.
- The original range of the analog output is not changed.

#### 5.3.1 Example Application Program 1

In voltage output mode, the 1DA converts digital values from 0 ~ 4000 to the analog output of 0 ~ 10 Volts. If using a digital range of 0 ~ 10000 in the program, the range must be converted to 0 ~ 4000 as shown in the programming example below. Digital values for conversion to analog are stored in D8114. The analog output does not have exact resolution of 2.5mV because the digital value is converted from 0 ~ 10000 to a range of 0 ~ 4000.

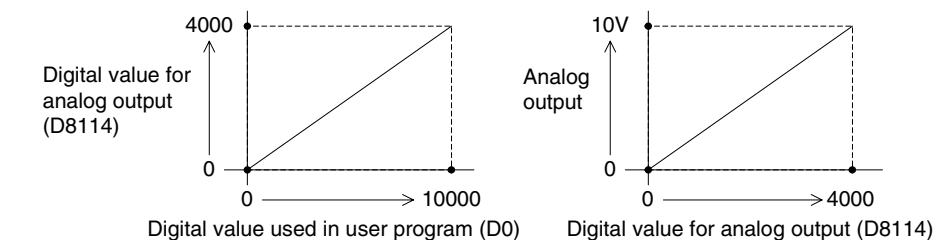

If a digital value in the range of 0 ~ 10000 is used in D0, please see below.

$$\text{Digital value used in user program: (D8114)} = 2 \times D0 \div 5$$

The value of D0 is given as a multiple of five.

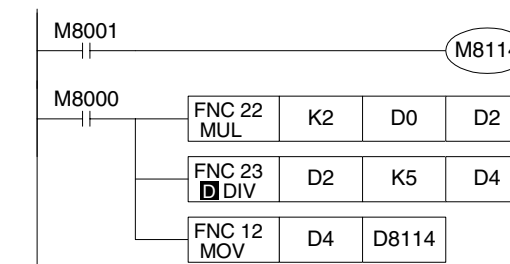

#### 5.3.2 Example Application Program 2

In current output mode, the 1DA converts digital values from 0 ~ 2000 to the analog output of 0 ~ 20 mA. If using a digital range of 0 ~ A in the program, the range must be converted to 0 ~ 4000 as shown in the programming example below. Digital values for conversion to analog are stored in D8114. The analog output does not have exact resolution of 8 μA because the digital value is converted from 0 ~ A to a range of 0 ~ 2000. A > 0.

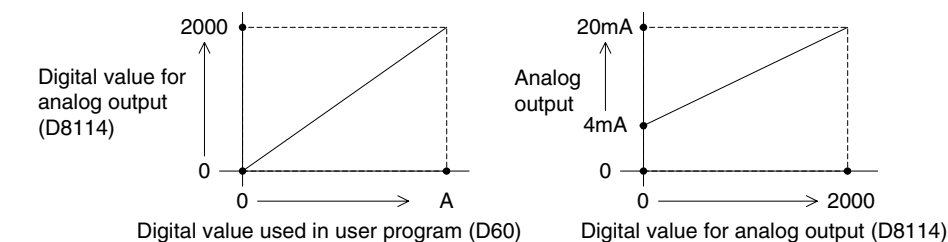

If a digital value in the range of 0 ~ A is used in D60, please see below.

$$\begin{aligned} \text{Digital value used in user program: D8114} &= 2000 \times D60 \div A \\ &= 2000 \times D60 \div 10000 \text{ (In } A = 10000 \text{ case)} \\ &= D60 \div 5 \end{aligned}$$

The value of D60 is given as a multiple of five

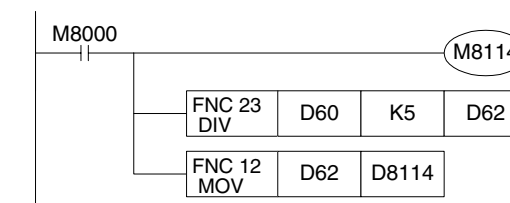

Manual number : JY992D96401

Manual revision : B

Date : JULY 2004